



Hewlett Packard
Enterprise

HPE Data Protector

Software Version: 9.09

Zero Downtime Backup Administrator's Guide

Document Release Date: March 2017
Software Release Date: March 2017

Legal Notices

Warranty

The only warranties for Hewlett Packard Enterprise Development LP products and services are set forth in the express warranty statements accompanying such products and services. Nothing herein should be construed as constituting an additional warranty. HPE shall not be liable for technical or editorial errors or omissions contained herein.

The information contained herein is subject to change without notice.

Restricted Rights Legend

Confidential computer software. Valid license from HPE required for possession, use or copying. Consistent with FAR 12.211 and 12.212, Commercial Computer Software, Computer Software Documentation, and Technical Data for Commercial Items are licensed to the U.S. Government under vendor's standard commercial license.

Copyright Notice

© Copyright 2017 Hewlett Packard Enterprise Development LP

Trademark Notices

Adobe™ is a trademark of Adobe Systems Incorporated.

Microsoft® and Windows® are U.S. registered trademarks of Microsoft Corporation.

UNIX® is a registered trademark of The Open Group.

This product includes an interface of the 'zlib' general purpose compression library, which is Copyright © 1995-2002 Jean-loup Gailly and Mark Adler.

Documentation Updates

The title page of this document contains the following identifying information:

- Software Version number, which indicates the software version.
- Document Release Date, which changes each time the document is updated.
- Software Release Date, which indicates the release date of this version of the software.

To check for recent software updates: <https://softwaresupport.hpe.com/patches>.

To verify that you are using the most recent edition of a document, go to: <https://softwaresupport.hpe.com/manuals>.

This site requires that you register for an HPE Passport and sign in. To register for an HPE Passport ID, go to: <https://hpp12.passport.hpe.com/hppcf/login.do>.

Or click the **Register** link at the top of the HPE Software Support page.

You will also receive updated or new editions if you subscribe to the appropriate product support service. Contact your HPE sales representative for details.

Support

Visit the HPE Software Support Online web site at: <https://softwaresupport.hpe.com>

This web site provides contact information and details about the products, services, and support that HPE Software offers.

HPE Software online support provides customer self-solve capabilities. It provides a fast and efficient way to access interactive technical support tools needed to manage your business. As a valued support customer, you can benefit by using the support web site to:

- Search for knowledge documents of interest
- Submit and track support cases and enhancement requests
- Download software patches
- Manage support contracts
- Look up HPE support contacts
- Review information about available services
- Enter into discussions with other software customers
- Research and register for software training

Most of the support areas require that you register as an HPE Passport user and sign in. Many also require a support contract.

To register for an HPE Passport ID, go to:

<https://hpp12.passport.hpe.com/hppcf/createuser.do>

To find more information about access levels, go to:

<https://softwaresupport.hpe.com/web/softwaresupport/access-levels>

HPE Software Solutions Now accesses the HPESW Solution and Integration Portal Web site. This site enables you to explore HPE Product Solutions to meet your business needs, includes a full list of Integrations between HPE Products, as well as a listing of ITIL Processes. The URL for this Web site is <https://softwaresupport.hpe.com>.

Contents

- Part 1: HPE P4000 SAN Solutions 12
 - Chapter 1: Configuration 13
 - Introduction 13
 - Prerequisites 13
 - Limitations 13
 - Configuring the integration 14
 - CIMOM provider connection configuration 14
 - Chapter 2: Backup 15
 - Chapter 3: Restore 16
 - Chapter 4: Troubleshooting 17
 - Before you begin 17
 - Checks and verifications 17

- Part 2: HPE P6000 EVA Disk Array Family 18
 - Chapter 5: Configuration and maintenance 19
 - Introduction 19
 - Prerequisites 19
 - Limitations 20
 - ZDB database – SMISDB 21
 - Configuring the integration 22
 - Setting login information for the SMI-S P6000 EVA Array provider 23
 - P6000 EVA disk group pairs configuration file 23
 - HPE CA P6000 EVA HOME configuration file 24
 - Configuration of the backup system 25
 - Use of mirrorclones for zero downtime backup 25
 - Maintaining the integration 26
 - Querying the SMISDB 27
 - Checking the SMISDB for consistency 27
 - Purging the SMISDB 27
 - Deleting replicas and the associated SMISDB entries 27
 - Excluding and including sessions 28
 - Chapter 6: Backup 29
 - Introduction 29
 - Snapshot types 30
 - Snapshot sources 30
 - ZDB types 30
 - Replica creation and reuse 31
 - Replica storage redundancy levels 32
 - ZDB in HPE CA+BC P6000 EVA environments 33
 - HPE CA+BC P6000 EVA ZDB scenarios 34

ZDB in HP-UX LVM mirroring environments	38
Creating backup specifications	40
Backup options	44
Chapter 7: Restore	55
Introduction	55
Standard restore	55
Instant recovery	55
Instant recovery methods	56
Switching the disks	57
Copying replica data and retaining the source volume	57
Copying replica data without retaining the source volume	58
Instant recovery procedure	59
Instant recovery using the GUI	59
Instant recovery using the CLI	62
Instant recovery options	62
Instant recovery in HPE CA+BC P6000 EVA configurations	66
Instant recovery and LVM mirroring	66
Method 1 – instant recovery with reducing and extending the mirrors	66
Method 2 – instant recovery with splitting and merging the mirrors	67
Instant recovery in a cluster	68
Chapter 8: Troubleshooting	69
Before you begin	69
Checks and verifications	69
Backup problems	69
Instant recovery problems	74
Part 3: HPE P9000 XP Disk Array Family	77
Chapter 9: Configuration and maintenance	78
Introduction	78
Prerequisites	78
Limitations	80
ZDB database – XPDB	80
Configuring the integration	81
Command device handling	82
Configuring the user authentication data	83
User authentication data and the XPDB	84
Configuration procedure	84
P9000 XP LDEV exclude file	84
Automatic configuration of the backup system	85
Maintaining the integration	86
Chapter 10: Backup	87
Introduction	87
ZDB types	87
Replica types	87

Backup concepts	88
Creating backup specifications	88
Backup options	92
Chapter 11: Restore	101
Introduction	101
Standard restore	101
Split mirror restore	102
Split mirror restore procedure	103
Split mirror restore options	104
Split mirror restore in a cluster	107
HPE Serviceguard procedure	107
Instant recovery	107
Instant recovery procedure	108
Instant recovery using the GUI	108
Instant recovery using the CLI	110
Instant recovery options	110
Instant recovery and LVM mirroring	111
Instant recovery in a cluster	111
Chapter 12: Troubleshooting	112
Before you begin	112
Checks and verifications	112
General problems	112
Backup problems	113
Split mirror restore problems	116
Instant recovery problems	116
 Part 4: HPE 3PAR StoreServ Storage	 118
Chapter 13: Configuration	119
Introduction	119
Prerequisites	119
Limitations	120
Configuring the integration	121
CIMOM provider connection configuration	121
Connection configuration data	121
Configuration procedure	122
Chapter 14: Backup	123
ZDB types	123
ZDB for HPE 3PAR Remote Copy environments	124
Supported HPE 3PAR Remote Copy Configurations	124
HPE 3PAR Remote Copy Modes	124
HPE ZDB 3PAR Remote Copy scenarios	126
Limitations	128
ZDB in HP-UX LVM mirroring environments	128
Creating the backup specification	128

Backup options	131
Chapter 15: Restore	138
Instant recovery	138
Instant recovery methods	139
Instant recovery procedure	139
Instant recovery using the GUI	139
Instant recovery using the CLI	141
Instant recovery options	141
Instant Recovery for 3PAR Remote Copy environments	142
Introduction	142
Prerequisites	142
Overview	143
Supported Remote Copy Configurations for Instant Recovery	143
Configuration I – local HPE 3PAR Remote Copy Replica	143
Configuration II – remote HPE 3PAR Remote Copy Replica	144
Instant recovery in HPE 3PAR Remote Copy environments	145
Identifying the current configuration	146
Performing failover	147
Modifying or removing the Remote Copy group	147
Performing instant recovery	147
Rebuilding the Remote Copy group	148
Chapter 16: Troubleshooting	149
Before you begin	149
Checks and verifications	149
Backup problems	149
Restore problems	154
Instant recovery problems	154
Part 5: EMC Symmetrix	156
Chapter 17: Configuration	157
Introduction	157
EMC Symmetrix database file and Data Protector EMC log file	158
EMC Symmetrix database file	158
Data Protector EMC log file	158
Configuring the integration	158
Creating Data Protector EMC database file	159
Rebuilding EMC Symmetrix database file	159
Automatic configuration of backup system	160
Chapter 18: Backup	161
Introduction	161
ZDB types	161
Backup concepts	161
Backup in LVM mirroring configurations	161
Creating backup specifications	162

Backup options	164
Backup disk usage	166
Testing backed up data	167
EMC test options	167
Checking your restored data	168
Chapter 19: Restore	169
Introduction	169
Standard restore	169
Split mirror restore	170
Split mirror restore procedure	170
Split mirror restore options	171
Split mirror restore in a cluster	173
HPE Serviceguard procedure	174
Chapter 20: Troubleshooting	175
Before you begin	175
Checks and verifications	175
Backup problems	175
Error messages	178
Split mirror restore problems	180
Error messages	182
Recovery using the EMC agent	184
Part 6: NetApp Storage	186
Chapter 21: Configuration	187
Introduction	187
Prerequisites	187
Limitations	188
ZDB database - SMISDB	188
Configuring the integration	189
Connection configuration data	189
Configuration procedure	189
Chapter 22: Backup	191
Creating backup specification	191
Backup options	193
Chapter 23: Restore	198
Chapter 24: Troubleshooting	199
Before you begin	199
Checks and verifications	199
Part 7: EMC VNX Family	200
Chapter 25: Configuration	201
Introduction	201
Prerequisites	201

- Limitations 202
 - ZDB database - SMISDB 202
- Configuring the integration 203
 - Connection configuration data 203
 - Configuration procedure 203
- Chapter 26: Backup 205
 - Creating backup specification 205
 - Backup options 207
- Chapter 27: Restore 212
- Chapter 28: Troubleshooting 213
 - Before you begin 213
 - Checks and verifications 213
- Part 8: EMC VMAX Family 214**
 - Chapter 29: Configuration 215
 - Introduction 215
 - Prerequisites 215
 - Limitations 216
 - ZDB database - SMISDB 217
 - Configuring the integration 217
 - Connection configuration data 217
 - Configuration procedure 217
 - Chapter 30: Backup 219
 - Backup concepts 219
 - Creating backup specification 219
 - Backup options 222
 - Chapter 31: Restore 226
 - Chapter 32: Troubleshooting 227
 - Before you begin 227
 - Checks and verifications 227
- Appendix 228**
 - Scheduling ZDB sessions 228
 - Starting interactive ZDB sessions 228
 - Using the GUI 229
 - Using the CLI 229
 - Alternate paths support 229
 - Cluster configurations 230
 - Client on the application system in a cluster, Cell Manager in a cluster 231
 - Limitations 231
 - Cell Manager on the backup system in a cluster 232
 - Limitations 232

Cell Manager and client on the application system in a cluster	233
Limitations	233
Client on the application system in a cluster, Cell Manager not in a cluster	234
Client on the application system in a cluster, Cell Manager on the backup system in a cluster	235
Limitations	235
EMC GeoSpan for Microsoft Cluster Service	236
Scenarios	236
Instant recovery in a cluster	237
Vertias Cluster Volume Manager	237
HPE Serviceguard	238
Procedure	238
Microsoft Cluster Server	239
Instant recovery for in CA+BC configurations	240
Introduction	240
Prerequisites	240
Overview	240
Supported instant recovery configurations	241
Configuration I – local HPE Business Copy P6000 EVA	241
Configuration II – remote HPE Business Copy P6000 EVA	242
Instant recovery in HPE CA+BC P6000 EVA environments	243
Step 1: Identifying the current configuration	244
Step 2: Performing failover	247
Step 3: Modifying or removing the HPE CA P6000 EVA link	247
Step 4: Performing instant recovery	247
Step 5: Rebuilding the HPE CA P6000 EVA link (optional)	248
ZDB omnirc options	248
Common ZDB options	248
P6000 EVA Array and 3PAR StoreServ Storage specific options	250
Example	250
P9000 XP Array specific options	255
EMC specific options	257
User scenarios - examples of ZDB options	258
P6000 EVA Array integration	258
Example 1	258
Example 2	258
Example 3	259
P9000 XP Array integration	259
Example 1	259
Example 2	259
Example 3	260
Example 4	260
Conflicting Options	260
EMC integration	260
Example 1	260

Example 2	261
Backup system mount point creation	261
Filesystem and Microsoft Exchange Server backup	261
Application and disk image backup	262
Applications on filesystems	262
Applications on disk images + disk image backup	263
EMC Symmetrix—obtaining disk configuration data	264
Example 1	264
Example 2	266
Additional information for troubleshooting	268
HP-UX systems	268
Windows systems	269
 Send Documentation Feedback	 270

Part 1: HPE P4000 SAN Solutions

This part describes how to configure the Data Protector HPE P4000 SAN Solutions integration. For information on how to perform zero downtime backup and instant recovery using the HPE P4000 SAN Solutions integration, see the *HPE Data Protector Integration Guide for Microsoft Volume Shadow Copy Service*.

Chapter 1: Configuration

Introduction

This chapter describes the configuration of the Data Protector HPE P4000 SAN Solutions integration.

Prerequisites

- Obtain or install:

P4000 SAN Solutions licenses and components:

- HPE P4000 SAN/iQ software.
- HPE P4000 Virtual SAN Appliance Software / HPE P4000 Centralized Management Console.
- HPE P4000 SAN Solutions DSM (Device Specific Module) for MPIO.

For installation instructions, see the HPE P4000 SAN Solutions documentation. For information on supported product versions, see the latest support matrices at <https://softwaresupport.hpe.com/>.

Data Protector licenses and components:

- Appropriate zero downtime backup extension and instant recovery extension licenses-to-use (LTU).
- HPE P4000 Agent on the application system and the backup system.

For licensing information and installation and upgrade instructions, see the *HPE Data Protector Installation Guide*.

- Make sure the same operating system version is installed on the application system and the backup system.
- If the application system and the backup system reside in a Data Protector cell with secured clients, ensure that access between both systems is allowed in both directions.
- Source volumes must be created and presented to the application system and the backup system.

For additional prerequisites for using HPE P4000 SAN Solutions with the Data Protector Microsoft Volume Shadow Copy Service integration, see the *HPE Data Protector Integration Guide for Microsoft Volume Shadow Copy Service*.

Limitations

- In cluster environments, the backup system must not be in the same cluster with the application system. Additionally, the backup system cannot be the cluster virtual server, it can only be a cluster node.

For information on either of the following items, see the HPE Data Protector Product Announcements, Software Notes, and References:

- General Data Protector and integration-specific limitations
- Supported platforms and integrations
- Supported backup and connectivity topologies

Configuring the integration

Before you start with the configuration, make sure the prerequisites listed in ["Configuration " on the previous page](#) are fulfilled.

To be able to use the Data Protector HPE P4000 SAN Solutions integration with a storage system of the HPE P4000 SAN Solutions family, you must perform the mandatory configuration step. In this step, you need to provide the Data Protector HPE P4000 Agent the data which the ZDB agent will use to establish connection to a Common Information Model Object Manager (CIMOM) provider of your choice.

CIMOM provider connection configuration

In order to be able to connect to a CIMOM provider, the Data Protector HPE P4000 Agent needs the following information:

- Fully qualified domain name or IP address of the system where the CIMOM service is running
In case the system has multiple IP addresses configured, the address by which the system can be accessed by the Data Protector ZDB agent should be used.
- Whether the connection uses Secure Sockets Layer (SSL)
- Port number of the port on which the CIMOM service is accepting requests
- Username and password

This data must belong to a user account which has administrative privileges on the P4000 SAN Solutions storage system.

This information should be provided for each CIMOM provider that the Data Protector HPE P4000 Agent should connect to. Once added, the connection configuration data for a particular CIMOM provider is stored in a separate configuration file located on the Cell Manager in the directory:

Windows systems: `Data_Protector_program_data\server\db80\smisdb\p4000\login`

UNIX systems: `/var/opt/omni/server/db80/smisdb/p4000/login`

To add the connection configuration data, use the Data Protector `omnidbp4000` command. With `omnidbp4000`, you can also update or remove the configuration data, list the contents of the configuration files, and check if the connection to a particular CIMOM provider can be established. For these purposes, the `omnidbp4000` command provides the basic options `--add`, `--remove`, `--list`, and `--check`. For command syntax and usage examples, see the `omnidbp4000` reference page in the *HPE Data Protector Command Line Interface Reference* or the `omnidbp4000` man page.

Chapter 2: Backup

Zero downtime backup sessions that involve a storage system of the HPE P4000 SAN Solutions family can only be initiated through the Data Protector Microsoft Volume Shadow Copy Service integration.

For information about the supported configurations, ZDB types and replication techniques available on this storage system family, and storage system-specific ZDB considerations, see the *HPE Data Protector Concepts Guide*.

For additional storage system-specific ZDB considerations, procedure for configuring ZDB backup specifications, and instructions for running ZDB sessions, see the *HPE Data Protector Integration Guide for Microsoft Volume Shadow Copy Service*.

Chapter 3: Restore

Instant recovery sessions that involve a storage system of the HPE P4000 SAN Solutions family can only be initiated through the Data Protector Microsoft Volume Shadow Copy Service integration.

For information on replica handling during instant recovery, description of the instant recovery process, and storage system-specific instant recovery considerations, see the *HPE Data Protector Concepts Guide*.

For additional storage system-specific instant recovery considerations and instructions for running instant recovery sessions, see the *HPE Data Protector Integration Guide for Microsoft Volume Shadow Copy Service*.

Chapter 4: Troubleshooting

Before you begin

This chapter lists general checks and verifications that you may need to perform when you encounter problems with the P4000 SAN Solutions integration. For general Data Protector troubleshooting information, see the *HPE Data Protector Troubleshooting Guide*.

- Ensure that the latest official Data Protector patches are installed. For information on how to verify this, see the *HPE Data Protector Help* index: “patches”.
- For general Data Protector and integration-specific limitations, as well as recognized issues and workarounds, see the HPE Data Protector Product Announcements, Software Notes, and References.
- For an up-to-date list of supported versions, platforms, and other information, see <https://softwaresupport.hpe.com/>.

Checks and verifications

- On the application and backup systems, examine system errors logged into the debug.log file residing in the Data Protector log files directory.

Part 2: HPE P6000 EVA Disk Array Family

This part describes how to configure the Data Protector HPE P6000 EVA Disk Array Family integration, how to perform zero downtime backup and instant recovery using the HPE P6000 EVA Disk Array Family integration, and how to resolve the integration-specific Data Protector problems.

Chapter 5: Configuration and maintenance

Introduction

This chapter describes the configuration of the Data Protector HPE P6000 EVA Disk Array Family integration. It also provides information on the ZDB database and on how to maintain the integration.

Prerequisites

- Obtain or install:

P6000 EVA Array licenses and components:

- HPE Command View (CV) EVA and Virtual Controller Software (VCS or XCS).
For installation instructions, see the SMI-S P6000 EVA Array provider and VCS or XCS documentation. For information on supported product versions, see the latest support matrices at <https://softwaresupport.hpe.com/>.
- HPE Continuous Access (CA) P6000 EVA and/or HPE Business Copy (BC) P6000 EVA license and microcode.

- **HP-UX systems:** HP-UX MirrorDisk/UX software license.

This license is required to enable mirroring functionality on HP-UX LVM.

- An appropriate multi-path device management software.

The software must be installed on the application system and the backup system.

HP-UX systems: HPE Secure Path (HP-UX)

On HP-UX 11.31 systems, the multi-path device management software is not required since the operating system has native device multi-pathing capability.

Linux systems: HPE Device Mapper Multipath Enablement Kit for HPE Disk Arrays 4.2.0 or newer version

To configure the installed multi-path device management software:

- i. Start the multipath daemon and run the following command to configure the daemon so that it gets started during system startup:

Red Hat Enterprise Linux: `chkconfig multipathd on`

SUSE Linux Enterprise Server: `chkconfig boot.multipath on`

- ii. Prevent the multipath device management software from queuing for unavailable disk volumes by modifying its configuration file.

Add the following line into the `defaults` section of the file `/etc/multipath.conf`:

```
no_path_retry          fail
```

Ensure that this `no_path_retry` parameter value is not overridden by analogous entries in the `device` sections of the same file in which the corresponding P6000 EVA Array storage systems are configured.

- iii. Ensure that the correct preferred names are used for pathnames that are referencing the same device for physical volumes as they are used in device-mapper multipathing.

Open the `lvm.conf` file, residing in the `/etc/lvm/` directory, and set the following variable:

```
preferred_names = [ "^/dev/mpath/", "^/dev/mapper/mpath", "^/dev/[hs]d" ]
```

Windows systems: HPE MPIO Full Featured DSM (Device Specific Module) for HPE P6000 EVA Disk Array Family

- A license for controlling the P6000 EVA Array storage system.
- SANworks Snapshot licenses.

Data Protector licenses and components:

- Appropriate zero downtime backup extension and instant recovery extension licenses-to-use (LTU).
- HPE P6000 / HPE 3PAR SMI-S Agent on the application system and the backup system.

For installation and upgrade instructions and licensing information, see the *HPE Data Protector Installation Guide*.

- Make sure the same operating system version is installed on the application system and the backup system.
- If the application system and the backup system reside in a Data Protector cell with secured clients, ensure that access between both systems is allowed in both directions.
- Verify that the backup system is listed inside Command View EVA.
- Using Command View EVA, create source volumes and present them to the application system.

Prerequisites for Windows systems

- On Windows Server 2003 and Windows Server 2008 systems, disable the operating system option **Automatic mounting of new volumes**. In the Command Prompt window, run the command `mountvol /N`.
- Do not manually mount target volumes that were created by Data Protector.

For additional prerequisites for using HPE P6000 EVA Disk Array Family with the Data Protector Microsoft Volume Shadow Copy Service integration, see the *HPE Data Protector Integration Guide for Microsoft Volume Shadow Copy Service*.

Limitations

- In server clusters, the backup system cannot be the cluster virtual system, it can only be a physical cluster node.

For other limitations on clusters, see "[Cluster configurations](#)" on page 230.

- In zero downtime backup sessions using multisnapping, only two snapshot types are supported by default: standard snapshot and snapclone. For information if your P6000 EVA Array environment supports multisnapping using vsnaps, see your Command View (CV) documentation. For

instructions on how to enable support for the vsnap snapshot type in multisnapping ZDB sessions in Data Protector, contact HPE technical support.

For information on either of the following items, see the HPE Data Protector Product Announcements, Software Notes, and References:

- general Data Protector and integration-specific limitations
- supported platforms and integrations
- supported backup and connectivity topologies

For information on supported configurations, see the *HPE Data Protector Concepts Guide*.

ZDB database – SMISDB

ZDB database for the Data Protector HPE P6000 EVA Disk Array Family integration is referred to as **SMISDB**. It keeps information about:

- Management systems on which Command View EVA runs. For each system, the following is stored:
 - Hostname as recognized in the IP network.
 - Port number through which the HPEP6000 / HPE 3PAR SMI-S Agent communicates with the SMI-S P6000 EVA Array provider. For non-SSL connections, the default port is 5988. For SSL connections, the default port is 5989.
 - User name and encoded password for the SMI-S P6000 EVA Array provider login.
- Policies for redirecting the creation of snapclones and mirrorclones into specific disk groups.
- Information about the home (HPE CA+BC P6000 EVA configurations).
- Replicas (groups of target volumes created in different backup sessions) kept on the disk array. For each target volume, the information includes:
 - ID of the ZDB session that produced the target volume
 - Time when the session was performed
 - Name of the backup specification used in the session
 - Name, ID, and WWN of the target volume created in the session
 - Name and ID of the P6000 EVA Array storage system on which the target volume resides
 - Snapshot type used for the replica (vsnap, standard snapshot, snapclone) and the type of source volumes of which the snapshots were created (original volume, mirrorclone)
 - ID of the source volume used in the session
 - IR flag (indicating that the target volume can be used for instant recovery)
 - Purge flag (indicating that the target volume is marked for deletion)

- Storage redundancy level (Vraid type) of the target volume
- Exclusion flag (indicating that the replica is not involved in the replica set rotation and cannot be used for instant recovery)
- Names of the application and backup systems involved in the session

This information is written to the SMISDB when a replica is created, and is deleted from the database when a replica is deleted.

- Retained source volumes flag (after the instant recovery session, if the corresponding instant recovery option was selected).
- Mirrorclones created by Data Protector (tracked similarly as the replicas which cannot be used for instant recovery and are excluded from use).

SMISDB resides on the Cell Manager in:

Windows systems: `Data_Protector_program_data\server\db80\smisdb`

UNIX systems: `/var/opt/omni/server/db80/smisdb`

Configuring the integration

Before you start with the configuration, make sure the prerequisites listed in ["Introduction" on page 19](#) are fulfilled. In addition, do the following:

HPE BC P6000 EVA configurations: Connect the application and backup systems to the same P6000 EVA Array storage system. For ZDB to tape or ZDB to disk+tape, attach a backup device to the backup system.

For more information about HPE BC P6000 EVA configurations, see the *HPE Data Protector Concepts Guide*.

Combined (HPE CA+BC P6000 EVA) configurations: For this configuration, you need at least two P6000 EVA Array storage systems located at different sites (with at least one HPE CA P6000 EVA license, to set up the HPE CA P6000 EVA links between the arrays, and at least one HPE BC P6000 EVA license on the array where the replicas will be created).

Connect the application system to the P6000 EVA Array storage system containing source volumes (local disk array), and the backup system to the P6000 EVA Array storage system containing target volumes (remote disk array). Connect a backup device to the backup system.

For more information about HPE CA+BC P6000 EVA configurations, see ["ZDB in HPE CA+BC P6000 EVA environments" on page 33](#) and the *HPE Data Protector Concepts Guide*.

HP-UX LVM mirroring configurations: Group the physical volumes of a volume group into physical volume groups (PVGs). Each PVG may contain physical volumes from one or more P6000 EVA Array storage systems. All logical volumes in a volume group must be created with the `PVG-strict` allocation policy. Consequently, the mirrors will be created on different PVGs.

Before you run a backup, ensure that the mirrors of logical volumes involved in the backup are consistent. You can achieve this by running the `vgsync` command. Alternatively, specify the `vgsync` command in the **pre-exec** option in the backup specification. Consequently, Data Protector automatically runs the command before the replica is created.

For more information about LVM mirroring configurations, see ["ZDB in HP-UX LVM mirroring environments" on page 38](#) and the *HPE Data Protector Concepts Guide*. For more information about LVM mirroring, see the document *Managing Systems and Workgroups: A Guide for HP-UX System Administrators*.

To configure the integration:

- Provide the login information for the SMI-S P6000 EVA Array provider running on a management system. See ["Setting login information for the SMI-S P6000 EVA Array provider" below](#).
- If desired, set disk group pairs. See ["P6000 EVA disk group pairs configuration file" below](#).
- For HPE CA+BC P6000 EVA configurations, set the home disk array. For details, see ["HPE CA P6000 EVA HOME configuration file" on the next page](#). If the home is not set, the HPE P6000 / HPE 3PAR SMI-S Agent considers the configuration to be non-failover. In this case, replicas will always be created on the disk array remote to the current source.

Setting login information for the SMI-S P6000 EVA Array provider

Before starting ZDB sessions, provide login information for the SMI-S P6000 EVA Array provider running on a management system.

To set, delete, list, or check the login information, use the `omnidbsmis` command. For command syntax and examples, see the `omnidbsmis` reference page in the *HPE Data Protector Command Line Interface Reference* or the `omnidbsmis` man page.

If a failover from the active to the standby management system happens, proceed as follows:

- If standby and failed management systems have the same hostname, no action is needed.
- If standby and failed management systems have different hostnames, remove the failed system from the Data Protector configuration, and then add the new management system.

If your SMI-S P6000 EVA Array provider is using non-default port numbers for SSL and non-SSL connections, enter the settings in the SMISDB database accordingly (use `omnidbsmis`).

To verify the configuration of SMI-S P6000 EVA Array provider, run `omnidbsmis -ompasswd -check [-host ClientName]`. It is recommended to run this command before backup and instant recovery sessions to check if the SMI-S P6000 EVA Array provider is operational and available on the network.

P6000 EVA disk group pairs configuration file

You can create snapclones and mirrorclones in a different disk group from that of the source volumes (original virtual disks). In this way, you help to reduce potential application performance degradation, since different physical disks are used for the source volumes and the replica. Note that standard snapshots and vsnaps are always created in the disk group of their source volumes whether the latter are original volumes or mirrorclones.

To set disk group pairs, use the `omnidbsmis` command. For command syntax and examples of manipulating the disk group pairs configuration file, see the `omnidbsmis` man page. The file template is as follows.

```
#  
# HPE Data Protector A.09.00
```

```
#  
# P6000 EVA SMI-S disk group pairs configuration file  
#  
# Syntax:  
#"EVA Node World Wide Name": "Working DG1", "Backup DG1"  
#"EVA Node World Wide Name": "Working DG2", "Backup DG2"  
#  
# Example:  
# "500508B101007000": "dg1", "dg2"  
#  
#  
#  
# End of file
```

Note: After the instant recovery session that uses the instant recovery method of switching the disks, the disk group of the former target volumes becomes the disk group of the new source volumes. In cases where characteristics of the two disk groups differ, the application system performance may be affected.

HPE CA P6000 EVA HOME configuration file

This section is only applicable if you perform ZDB in HPE CA+BC P6000 EVA configurations.

Due to HPE P6000 EVA Disk Array Family hardware limitations, the concept of a defined home disk array does not exist within the HPE P6000 EVA Disk Array Family. The HPE P6000 / HPE 3PAR SMI-S Agent introduces this concept with the static HPE CA P6000 EVA HOME configuration file. By setting the home disk array, you influence the Data Protector behavior in case of a failover. For more information, see ["ZDB in HPE CA+BC P6000 EVA environments" on page 33](#).

To create an P6000 EVA HOME configuration file template and put it into its default location (*Data_Protector_program_data\server\db80\smisdb* or */var/opt/omni/server/db80/smisdb*), use the `omnidbsmis` command. This command is also used to upload the configuration file after editing (using an ASCII text editor like Notepad on Windows or VI on UNIX) back into its configuration directory. You can also list the DR groups with a specified P6000 EVA Array acting as a home and check if a specified DR group is part of an HPE CA+BC P6000 EVA configuration. For command syntax and examples, see the `omnidbsmis` man page.

File template

```
#  
# HPE Data Protector A.09.00  
#  
# P6000 EVA SMI-S Continuous Access HOME configuration file  
#  
# Syntax:  
# [EVA WWN]  
# DRGroup1,DRGroup2  
# DRGroup3  
#  
# Example:
```



```
# [50001FE15005DC00]
# "DRGroup 001"
#
#
#
# End of file
```

Configuration of the backup system

As part of a ZDB session, Data Protector performs necessary configuration steps, such as configuring volume groups, filesystems, mount points on the backup system. Data Protector can either create the same volume group structure on the backup system as it is on the application system and mounts the volumes to such mount points, or it can mount the volumes to the mount points specified in the backup specification.

For more information on creation of mount points on the backup system, see the *HPE Data Protector Concepts Guide*.

Before running backup sessions, ensure that the host representing the backup system is configured on the P6000 EVA Array storage system. If it is not, configure it manually. If the hostname on the P6000 EVA Array storage system is different from the network hostname, use the `omnirc` options `EVA_HOSTNAMEALIASES` to define the backup system object name.

Cluster environment:

If the backup system is a cluster virtual server, configure host objects using Command View in such a way that only one cluster node is configured in one host object. Additionally, set the option `EVA_HOSTNAMEALIASES` to the appropriate host object on each cluster node.

For more information on the option, see ["ZDB omnirc options" on page 248](#).

Use of mirrorclones for zero downtime backup

Specific firmware revisions of disk arrays of the HPE P6000 EVA Disk Array Family support mirrorcloning, a special type of local replication. A mirrorclone is a dynamic replica of a storage volume, which is kept updated with changes made to the original storage volume via a local replication link. Replication between the original storage volume and its mirrorclone can be suspended and later re-established. For each storage volume, a single mirrorclone can be created on the disk array. Mirrorclones can be further replicated. As a result, mirrorclone snapshots are created – either standard snapshots or vsnaps. Each mirrorclone can have several snapshots attached and they can only be of the same type. For more information on the snapshot types, see ["Snapshot types" on page 30](#).

Mirrorclone is one of the snapshot sources available for zero downtime backup in Data Protector. If selected in a ZDB backup specification, snapshots of mirrorclones of the selected storage volumes are created in the corresponding ZDB sessions, rather than snapshots of the storage volumes themselves. See ["Creation of a standard snapshot of a mirrorclone" below](#).

Creation of a standard snapshot of a mirrorclone

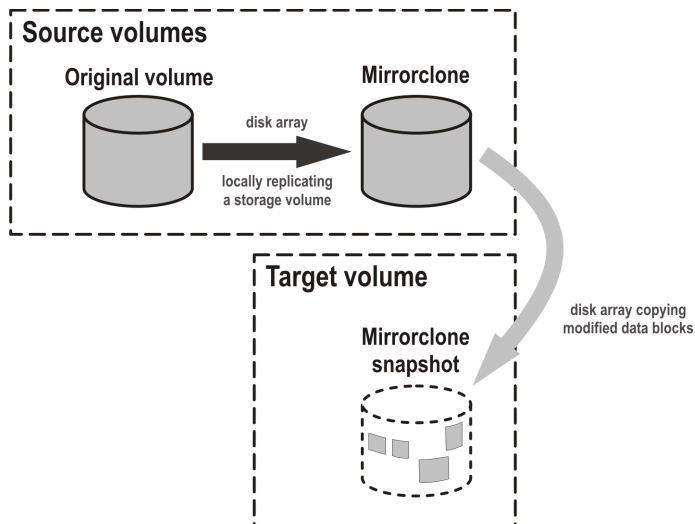

The advantage of this approach is in further shortening the backup window during which performance of the application using the source volumes for its data storage is affected. Mirrorclones can be created in advance using Command View EVA. However, if they do not exist yet when a ZDB session starts, but mirrorclone is selected as the snapshot source in the ZDB backup specification, they are automatically created by the HPE P6000 / HPE 3PAR SMI-S Agent at the beginning of the session. For more information on the snapshot sources, see ["Snapshot sources" on page 30](#). For information on creating mirrorclones outside Data Protector, see the HPE P6000 EVA Disk Array Family documentation.

In Data Protector instant recovery sessions, data from the mirrorclone snapshots is restored directly to the corresponding original volumes. See ["Instant recovery using a standard snapshot of a mirrorclone" below](#).

Instant recovery using a standard snapshot of a mirrorclone

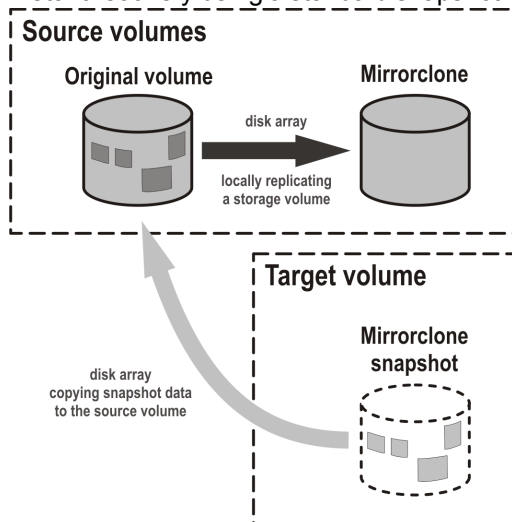

You can delete mirrorclones that were created by Data Protector using the `omnidbsmis` command. For more information, see ["Deleting replicas and the associated SMISDB entries" on the next page](#).

Maintaining the integration

Maintenance tasks are divided into the following categories:

- Querying information. See ["Querying the SMISDB" below](#).
- Checking consistency. See ["Checking the SMISDB for consistency" below](#).
- Deleting backup sessions. See ["Purging the SMISDB" below](#) and ["Deleting replicas and the associated SMISDB entries" below](#).
- Excluding and including ZDB sessions. See ["Excluding and including sessions" on the next page](#)

Querying the SMISDB

Using the `omnidbsmis` command, you can list:

- all available zero downtime backup (ZDB) sessions
- all ZDB sessions based on a specific ZDB backup specification
- all ZDB sessions that are excluded from the replica set rotation
- obsolete volumes marked for purging
- disk group redirection configuration
- sets of retained source volumes, kept for forensic purposes after instant recovery
- details on a specific successful ZDB session and a report about all ZDB sessions based on a specific ZDB backup specification

For HPE CA+BC P6000 EVA configurations, you can list data replication (DR) groups with a specified P6000 EVA Array acting as home. You can also check if a specified DR group is defined to be part of the HPE CA+BC P6000 EVA HOME configuration in this cell.

For command syntax and examples, see the *HPE Data Protector Command Line Interface Reference* or the `omnidbsmis` man page.

Checking the SMISDB for consistency

Data Protector can check the persistent data in the SMISDB against the P6000 EVA Array storage system and list the differences. Note that the check operation cannot detect whether the P6000 EVA Array configuration is correct or if the SMI-S P6000 EVA Array provider is currently operational. It just compares the saved data against the actual setup. This may provide misleading results, if the Command View EVA environment is not operating properly. If you use the results for an actual cleanup, verify the configuration first. The check operation also checks the entries which should be purged.

To check the SMISDB for consistency, use the `omnidbsmis` command. For details, see the *HPE Data Protector Command Line Interface Reference* or the `omnidbsmis` man page.

Purging the SMISDB

During purge (normally started at the beginning of the backup session for the selected backup specification), the HPE P6000 / HPE 3PAR SMI-S Agent attempts to delete storage volumes marked for purging. You can also run the SMISDB purge manually using the `omnidbsmis` command. For details, see the *HPE Data Protector Command Line Interface Reference* or the `omnidbsmis` man page.

Deleting replicas and the associated SMISDB entries

Using the `omnidbsmis` command, you can delete:

- A specific ZDB session (and the replica created in it), identified by the session ID.
- ZDB sessions based on a specific ZDB backup specification (and the replicas created in them), identified by the ZDB backup specification name.
- A specific pseudo-ZDB session that tracks mirrorclone creation performed by Data Protector (and the mirrorclones created in it), identified by the ID of the associated “regular” ZDB session.

In all cases, you can either remove the corresponding replica (target volumes) or the mirrorclones from the disk array as well as delete the session information about them (the associated entries) from the SMISDB, or delete only the session information from the SMISDB.

Regardless of the chosen deletion scope, you cannot perform instant recovery using the affected replica after deletion, because the associated information is missing from the SMISDB.

For details, see the *HPE Data Protector Command Line Interface Reference* or the `omnidbsmis` man page.

Excluding and including sessions

After a backup session, you can leave the replica mounted on the backup system for other purposes than backup (replica set rotation) and instant recovery. For example, you can use such replica for database replication.

However, the intended use time for these replicas may exceed the time that is allowed by the current active rotation scheme, in which Data Protector automatically recycles the oldest replica. In such cases, you can exclude a session (a replica) from use (the replica set rotation and possibility to perform instant recovery) and thus preserve all target volumes of the replica.

Once you exclude a replica, the session that created the replica will not be used for replica set rotation, cannot be used for instant recovery, and cannot be deleted using the Data Protector CLI. To use an excluded session in an instant recovery or to delete the target volumes created in this session, you must first include the replica.

Excluding or including sessions can be triggered from the CLI for an individual *backup session*. To exclude a session from use (the replica set rotation and possibility to perform instant recovery), use the `omnidbsmis` command.

Using the `omnidbsmis` command, you can:

- Exclude a session (the option `-exclude`)
- Include a session (the option `-include`)
- List all excluded sessions (the options `-session -excluded`)

For details, see the *HPE Data Protector Command Line Interface Reference* or the `omnidbsmis` man page.

Chapter 6: Backup

Introduction

This chapter describes configuring a filesystem and disk image ZDB sessions using the Data Protector GUI.

You should be familiar with the HPE P6000 EVA Disk Array Family concepts and procedures and basic Data Protector ZDB and instant recovery functionality. See the HPE P6000 EVA Disk Array Family documentation and the *HPE Data Protector Concepts Guide*.

Limitations

- The backup fails if you try to create a replica of a particular snapshot type and a replica of a different snapshot type (more specifically, standard snapshot or vsnap) for the same source volumes already exists. You must delete the existing replicas first. Snapclones are an exception. They do not block the creation of other snapshot types.
- Only one snapshot type for target volumes can be created during a ZDB session.
- When cloning process for a source volume is in progress, another snapshot (any type) of that source volume cannot be created.
- You cannot back up replicas (target volumes from existing and currently recorded backup sessions).
- If you perform ZDB in HPE Continuous Access + Business Copy (CA+BC) P6000 EVA environments, note that the objects belonging to each specific data replication (DR) group are omitted from the ZDB session if:
 - the DR group write history log (DR group log) is in a state other than “not in use”.
 - the DR group is in the “suspended” state.
 - the DR group is in the “failsafe-locked” mode.

If a DR group write mode is “asynchronous”, the HPE P6000 / HPE 3PAR SMI-S Agent switches the mode into “synchronous” before starting ZDB. In this case, after ZDB is completed, the mode is reset to “asynchronous”.

- If there is not enough space for a standard snapshot or snapclone creation, the session fails.

Considerations

- If you do not select all of the filesystems on the disk for backup, Data Protector does not check if there are any filesystems that are not included in the backup specification and creates a replica of the entire disk. During instant recovery, the entire disk is restored and overrides also the filesystems that are not included in the backup specification, resulting in a possible data loss.
- If the source disks selected in a zero downtime backup specification are located on more than one P6000 EVA Array storage system, Data Protector will perform multisnapping for each unit separately, provided that it is not backing up the Oracle Server data in ASM configurations and multisnapping is not enforced by the `omnirc` option `SMISA_ENFORCE_MULTISNAP`.

For more information on the backup-related considerations, see the *HPE Data Protector Concepts Guide*. For detailed information on the backup-related problems and possible workarounds, see ["Backup problems" on page 69](#).

Snapshot types

Data Protector supports the following snapshot types:

- snapshot *with* pre-allocation of disk space (**standard snapshot**).
- snapshot *without* pre-allocation of disk space (virtually capacity-free snapshot or shortly **vsnap**).
- complete copy of the source volume (the virtual disk containing original data), which is independent of the source volume (**snapclone**).

You can select the snapshot type in the GUI when creating a ZDB backup specification. For more information on snapshot types, see the *HPE Data Protector Concepts Guide*.

Note: The snapclone snapshot type can only be used when the snapshot source selected in the ZDB backup specification is original volume.

Additionally, with the standard snapshot and snapclone types of snapshots, Data Protector supports multisnapping. Multisnapping is simultaneous creation of target volumes so that the backup data is consistent not only on each individual target volume, but also across all the volumes that constitute a snapshot.

Snapshot sources

Data Protector can replicate the following kinds of storage volumes which are supported with disk arrays of the HPE P6000 EVA Disk Array Family:

- ordinary storage volume (**original volume**)

This term refers to a storage volume on which original data resides and which is presented to the application system.

- **mirrorclone**

This term refers to a mirrorclone of a storage volume on which original data resides. Mirrorclone is a particular type of local replication copy that can be created for a storage volume residing on a P6000 EVA Array. For more information on mirrorclones, see ["Use of mirrorclones for zero downtime backup" on page 25](#).

In a particular ZDB backup specification, when the selected snapshot source is mirrorclone, the only available snapshot types are standard snapshot and vsnap.

Additionally, in the above circumstances, if mirrorclones of the selected storage volumes do not exist yet when the corresponding ZDB session is started, Data Protector automatically creates them first. Automatic mirrorclone creation may prolong the first ZDB session started for such a ZDB backup specification. To prevent this, create mirrorclones of the original volumes in advance using Command View EVA.

ZDB types

Using the P6000 EVA Array integration, you can perform:

- **ZDB to disk**

The replica produced is kept on a disk array until reused. This replica becomes part of the replica set and can be used for instant recovery.

ZDB to disk is performed if the option **Track the replica for instant recovery** is selected in a ZDB backup specification, and **To disk** is selected when running/scheduling a backup.

- **ZDB to tape**

The replica produced is streamed to backup media, typically tape, according to the tape backup type you have selected (Full, Incr, Incr1-9).

This replica is deleted after backup if the option **Keep the replica after the backup** is cleared for the backup specification. If this option is selected, the replica remains on a disk array until reused and becomes part of the replica set. However, it cannot be used for instant recovery.

- **ZDB to disk+tape**

The replica produced is kept on a disk array until reused and is also streamed to backup media according to the tape backup type you have selected (Full, Incr, Incr1-9). This replica becomes part of the replica set and can be used for instant recovery.

ZDB to disk+tape is performed if the option **Track the replica for instant recovery** is selected in a ZDB backup specification, and **To disk+tape** is selected when running/scheduling a backup.

For more information on the ZDB types, see the *HPE Data Protector Concepts Guide*.

Replica creation and reuse

On UNIX systems, the HPE P6000 / HPE3PAR SMI-S Agent identifies physical volumes, the volume group, and all logical volumes residing on it. This enables replication of the entire volume group on the array. On Windows systems, the HPE P6000 / HPE 3PAR SMI-S Agent identifies partitions on a physical volume and entire disk is replicated. As a best practice, backup objects, such as filesystems or raw devices, from all logical volumes in a volume group and all partitions on physical volumes should be included in the backup. This helps in ensuring proper handling of filesystems and mount points during backup and restore.

A new replica is created and added to the replica set when:

- ZDB to tape is performed, in which **Keep the replica after the backup** is selected, but the specified **Number of replicas rotated** is not reached.
- ZDB to disk or ZDB to disk+tape is performed (**Track the replica for instant recovery** selected), and the specified **Number of replicas rotated** is not reached.

The oldest replica in the set is deleted first and then the new one is created when:

- ZDB to tape is performed in which **Keep the replica after the backup** is selected and the specified **Number of replicas rotated** is reached.
- ZDB to disk or ZDB to disk+tape is performed and the specified **Number of replicas rotated** is reached.

If the oldest replica needs to be deleted, target volumes of the oldest replica are reused for creation of a new replica. Before such reuse, the target volumes are first converted into **containers** whenever the following prerequisites are fulfilled:

- the target volumes are standard snapshots (provided that the current ZDB session uses multisnapping), vsnaps (provided that the current ZDB session uses multisnapping), or snapclones
- the target volumes have the same size, storage redundancy level, and disk group location as required by the current ZDB session

If the option **Keep the replica after the backup** is not selected, the replica and therefore all target volumes created during the backup session are deleted.

Note that for standard snapshots and snapclones, the number of replicas rotated has a significant impact on the amount of the required storage space. You should consider this storage requirement when defining your backup environment and/or backup policy.

Replica storage redundancy levels

The HPE P6000 EVA Disk Array Family implements nested (hybrid) storage redundancy (RAID) technology, referred to as Vraid. P6000 EVA Array storage systems support creation of snapshots and snapclones which have a different storage redundancy level (Vraid type) than their source storage volumes. Of the supported Vraid types, **Vraid1** consumes the most storage space, followed by **Vraid6**, **Vraid5**, and finally **Vraid0**.

While you can freely select a Vraid type for snapclones, specific constraints apply to the Vraid type selection for standard snapshots and vsnaps. For details, see the table that follows.

Allowed storage redundancy levels for standard snapshots and vsnaps

	Target volume – Vraid 6	Target volume – Vraid 1	Target volume – Vraid 5	Target volume – Vraid 0
Source volume – Vraid 6	Allowed	Allowed	Allowed	Allowed
Source volume – Vraid 1	Not allowed	Allowed	Allowed	Allowed
Source volume – Vraid 5	Not allowed	Not allowed	Allowed	Allowed
Source volume – Vraid 0	Not allowed	Not allowed	Not allowed	Allowed

If the redundancy level of source volumes is such that the specified snapshot redundancy level is not allowed, the zero downtime backup session creates snapshots with the redundancy level of their source volumes. The redundancy level is checked for each source volume separately.

Advantages

- By selecting the storage redundancy level, you can control the amount of storage space required.

Note: Target volumes of the **Vraid6** type can only be created in enhanced P6000 EVA disk groups.

In the Data Protector ZDB sessions during which mirrorclones are automatically created, the storage redundancy level of the source volumes (original volumes) is used for the mirrorclones. The storage redundancy level selected in the ZDB backup specification only applies to the target volumes.

ZDB in HPE CA+BC P6000 EVA environments

The P6000 EVA Array storage system containing source volumes is known as a **local (source) disk array**, while the P6000 EVA Array storage system on which the replicas are created is a **remote (destination) disk array**. The mirrored source and target volumes constitute a **copy set**.

Data replication is always initiated from a local to a remote array. It is executed over a logical grouping of P6000 EVA virtual disks, known as a **data replication (DR) group**. A DR group can contain up to eight copy sets and share a common HPE CA P6000 EVA log. Data replication control is always maintained at a DR group level.

The data backed up in HPE CA+BC P6000 EVA configurations can be restored using either instant recovery or the standard Data Protector restore from tape procedure. After backup to tape, you can choose to keep replicas on the array for purposes other than instant recovery (by selecting **Keep the replica after the backup** in the backup specification).

DR group write history log (DR group log) states

If data replication is not possible, for example, due to the broken connection between the local disk array and the remote disk array, new data and changes to the existing data on the application system are written to the DR group log which resides on the local disk array. Each DR group configured on the disk array has its own DR group log.

During the logging process, the status of the DR group logs for the source virtual disks is set to "logging". After the connection between the disk arrays is re-established, the contents of the DR group log are merged with the contents of the corresponding destination virtual disks on the remote disk array, so that the data redundancy is restored. For the duration of this activity, the status of the involved DR group logs is set to "merging". After the merge is complete, the status is set back to "not in use".

If the interruption of data replication is long-lasting, the storage space reserved for the DR group logs may run out. In this case, logs cannot hold all the changes. After the connection between the arrays is re-established, all original data in the involved DR groups has to be copied over. During this operation, the DR group log status is set to "copying", and is re-set to "not in use" after the operation is complete.

DR groups with the DR group log state other than "not in use" are excluded from backup.

DR group states

DR group states are "normal/good", "warning/attention", "severe/failure", and "unknown". Data consistency is only guaranteed when a DR group is in the "normal/good" or "warning/attention" state. DR groups that are found in other states are excluded from the backup session.

DR group modes

DR group modes are as follows:

- Suspend

This mode indicates that data replication is suspended and changes to the existing data are written to the log space until the replication is resumed. In the "suspend" mode, the DR group log state is set to "logging".

DR groups in such mode are excluded from backup.

- Failover

This mode indicates that the replication direction is reversed after a failover.

- Failsafe-locked

When a DR group is in this mode, write/read access to the source DR group is blocked due to the broken connection between the local disk array and the remote disk array. DR groups found in such a mode are excluded from the backup session.

HPE CA+BC P6000 EVA ZDB scenarios

The HPE P6000 / HPE 3PAR SMI-S Agent introduces the concept of a home disk array, which is defined inside a static HPE CA P6000 EVA HOME configuration file. By setting the home disk array using the `omnidbsmis` command and specifying HPECA P6000 EVA failover handling options in the backup specification, you influence the Data Protector behavior in case of a failover. The information about home is stored in SMISDB and is used by the HPE P6000 / HPE3PAR SMI-S Agent to determine the state of a DR group (ideal or failed over).

If you intend to maintain the replica location after a failover, you must set the home disk array before creating a ZDB backup specification. If you intend to follow the replication direction, setting home is optional. For more information, see ["HPE CA P6000 EVA HOME configuration file" on page 24](#) and the `omnidbsmis` man page.

To enable proper replication handling after a failover, make sure the disk array you set as home is also your source disk array (the disk array acting as source at the time of the first ZDB session).

HPE CA+BC P6000 EVA enables the following backup scenarios:

- Ideal, or non-failover scenarios, where replicas are always created on the array remote to current home.

A non-failover scenario

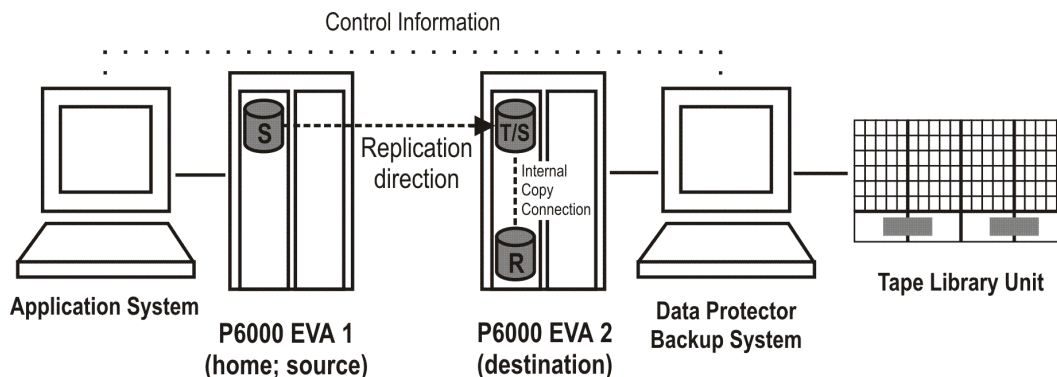

- Failover scenarios, where the roles of original source and destination are reversed after a failover. Replicas in such scenarios can be created:
 - On the disk array remote to the current source (**Follow direction of replication** backup option selected in the backup specification). It means that after a failover, the replication direction is

reversed and the replicas are created on the array that was originally a source P6000 EVA Array. "Failover scenario 1" below depicts an environment where the location of replica creation was switched after a failover.

Failover scenario 1

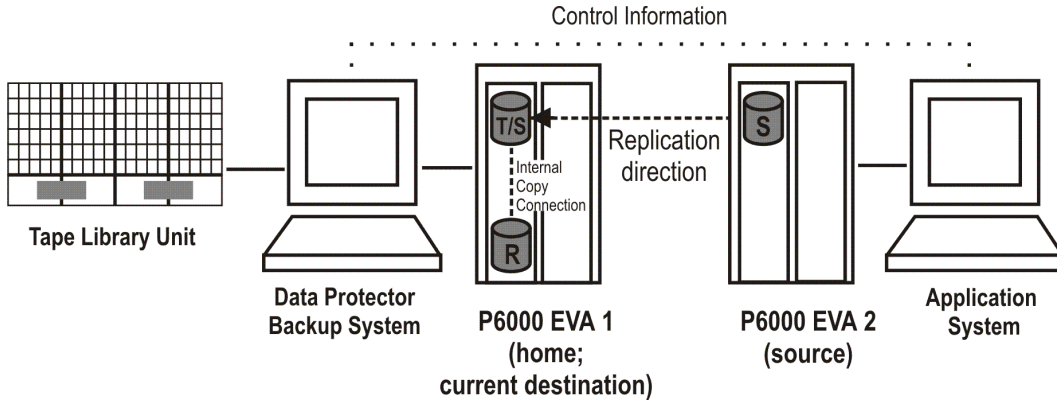

- On the array remote to home (**Maintain replica location** backup option is selected in the backup specification). It means that after a failover, replica location is maintained and replicas continue on the destination array that has now become a source array. Note that for the time of replica creation, the source array performance may be affected.

Failover scenario 2

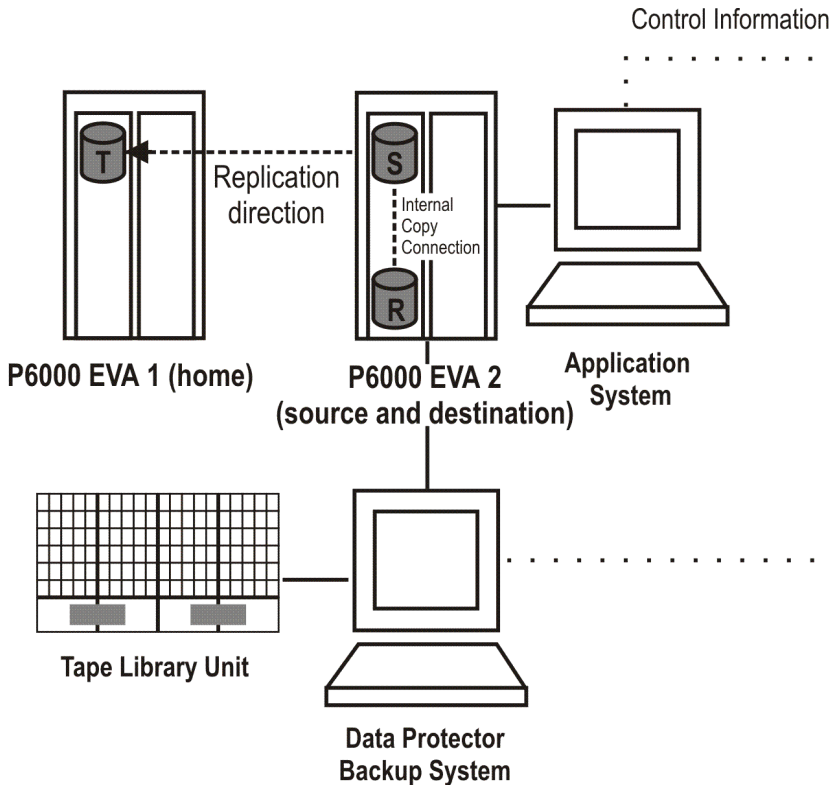

Consider the following:

- If you intend to always follow the replication direction, make sure the backup system has access to both local and remote P6000 EVA Array storage systems. Otherwise, after a failover, ZDB session fails because the replication direction switches and the backup system is no longer visible to the array where the replicas are created.
- If you intend to follow the replication direction, setting home in the HPE CA P6000 EVA HOME configuration file is optional. However, if you will maintain replica location, you must set up the home before you create a ZDB backup specification. If this is not done, the implications are as follows:
 - **Non-failover scenarios:**

ZDB sessions end successfully, but a warning that the home is not defined in the HPE CA P6000 EVA HOME configuration file is issued.
 - **Failover scenarios:**

Replicas are created on the array remote to current source. However, if you maintain replication direction because your backup environment is distributed and the backup system is only accessible to one array (where the replicas were originally created), ZDB session fails as the replicas are now created on another array.

The basic HPE CA+BC P6000 EVA configuration behavior is presented in the following diagram.

HPE CA+BC P6000 EVA configuration behavior

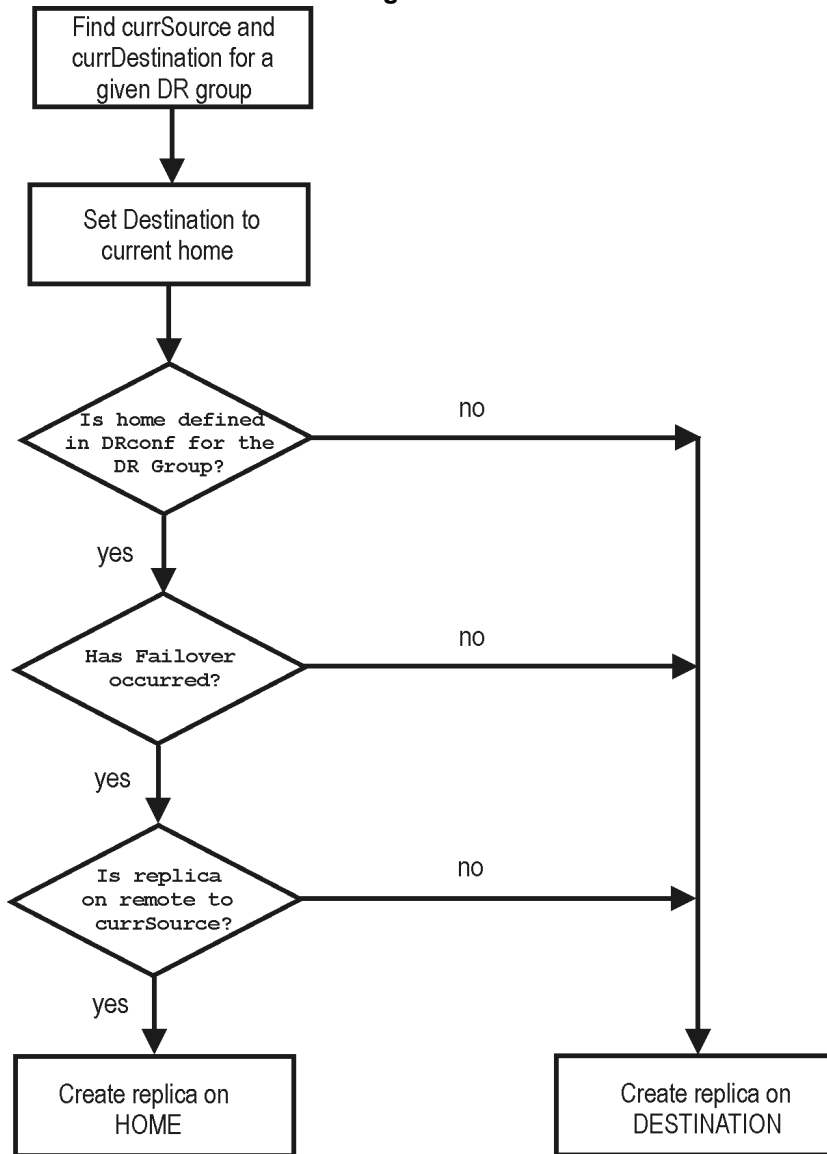

Replica set rotation

In the HPE CA+BC P6000 EVA non-failover scenarios, replicas are always created on the array remote to home. If the existing replica count (on the array where new replicas are) exceeds the specified number of replicas rotated, the oldest replica is deleted and the new one is created in its place (ensuring the maximum number of replicas is always within the defined rotation set).

In the HPE CA+BC P6000 EVA failover scenarios, replicas are created either on:

- The array remote to current source (or on the home disk array)
- The array remote to home

In the first case, the number of replicas in a rotation set is only checked on the current destination array. The replicas created on the current source, which was a destination before a failover, are ignored. Therefore, there are situations when two replica sets are created on both the source and destination arrays.

In the second case, replica set rotation verification happens in a normal way.

Note: Replica rotation set is only created if you select the option **Keep the replica after the backup** and specify **Number of replicas rotated**. Without these options specified, the replica is deleted from the array after the backup to tape is completed.

For more information about replica set rotation, see the *HPE Data Protector Concepts Guide*.

ZDB in HP-UX LVM mirroring environments

Your HP-UX LVM mirroring environment should be configured as follows:

- All logical volumes inside a volume group must be created with the `PVG-strict` allocation policy. Consequently, the mirrors will be created on different PVGs.
- As a best practice, different PVGs should be located on separate arrays. Consequently, mirrors are created on separate arrays.
- At least one PVG must contain a consistent mirror copy for all logical volumes of the volume group.

During a backup, Data Protector first checks the status of all mirror copies (see ["Checking the mirrors " on the next page](#)). Out of all consistent mirror copies (mirrors without stale extents), one is backed up, preferably the one residing on a different array than the first mirror copy. If such a mirror copy does not exist, the first mirror copy is backed up. If the `ZDB_LVM_PREFERRED_PVG` omnirc option is set, the mirror copy residing in the PVG specified in the option is backed up, provided that this mirror copy does not have stale extents. Otherwise, another mirror copy is selected for backup according to the algorithm described above.

For more information on the `ZDB_LVM_PREFERRED_PVG` omnirc option, see ["ZDB omnirc options" on page 248](#).

Checking the mirrors

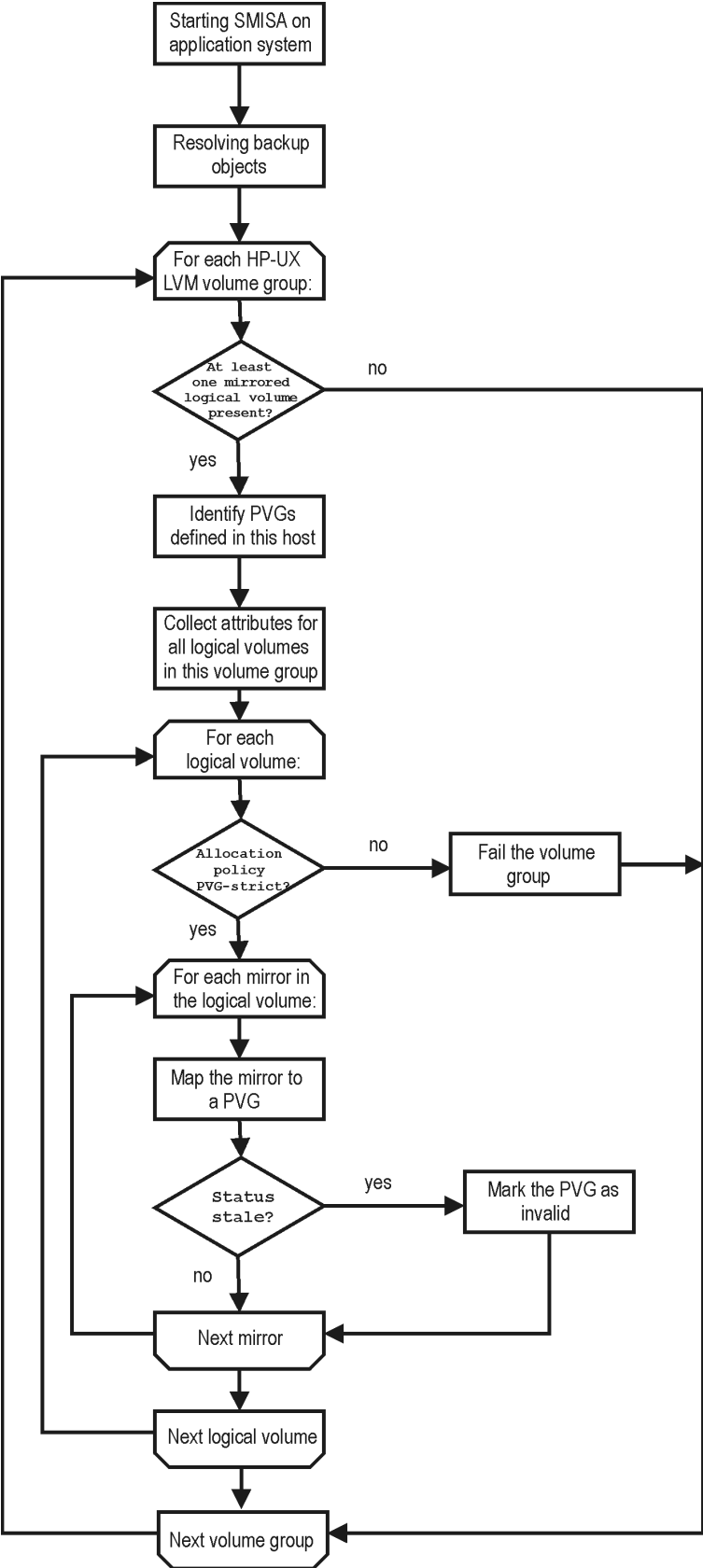

Data in replicas created using LVM mirroring can be restored in instant recovery sessions or sessions performing standard restore from tape.

Creating backup specifications

Considerations

- Consider all limitations that apply to the Data Protector P6000 EVA Array integration. See the HPE Data Protector Product Announcements, Software Notes, and References, the *HPE Data Protector Concepts Guide*, and the limitation list in ["Introduction" on page 19](#).
- If original volume is selected as the snapshot source in the ZDB backup specification, and mirrorclones of the selected storage volumes exist on the disk array when a corresponding ZDB session is started, the session fails.
- If mirrorclone is selected as the snapshot source in the ZDB backup specification, and mirrorclones of the selected storage volumes already exist when a corresponding ZDB session is started, the mirrorclones should not be presented to any system for the session to succeed.

Procedure

To create a ZDB backup specification for a disk array of the HPE P6000 EVA Disk Array Family using the Data Protector GUI (**Data Protector Manager**), follow the steps:

1. In the Context List, select **Backup**.
2. In the Scoping Pane, expand **Backup Specifications**. Right-click **Filesystem** (for both object types: filesystem and disk image) and click **Add Backup**.

The Create New Backup dialog box appears.

In the Filesystem pane, select the **Blank Filesystem Backup** template or some other template which you might have created. For information on templates, see the *HPE Data Protector Help* index: "backup templates".

Select **Snapshot or split mirror backup** as **Backup type** and **HPE P6000 EVASMI-S** as **Sub type**. For description of options, press **F1**.

Click **OK**.

3. Under Client systems, select **Application system** and **Backup system**. If the application system is part of a server cluster, select the virtual server.
4. Under Replication mode, select the P6000 EVA Array configuration. If you select **HPE Continuous Access P6000 EVA + HPE Business Copy P6000 EVA**, also specify a choice for Replica handling during failover scenarios.

For details about handling replica set rotation in HPE CA+BC P6000 EVA configurations, see ["HPE CA+BC P6000 EVA ZDB scenarios" on page 34](#).

P6000 EVA Array backup options

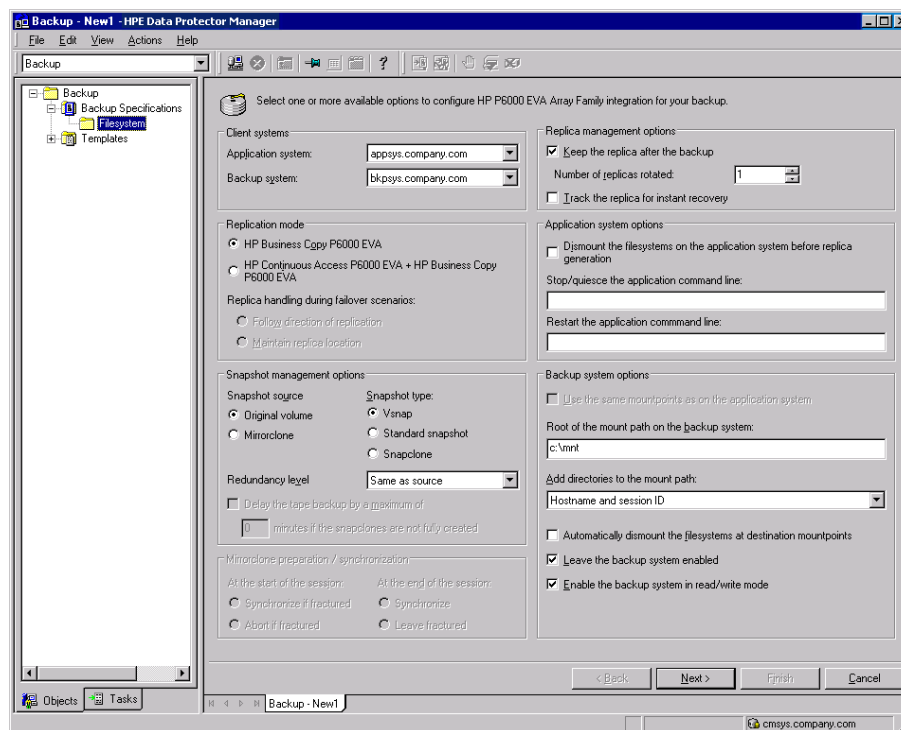

5. Under Snapshot management options, select the desired **Snapshot source**, **Snapshot type**, and **Redundancy level**.

Tip: For ZDB to disk+tape and ZDB to tape, and when snapclone is selected as the snapshot type, select **Delay the tape backup by a maximum of *n* minutes if the snapclones are not fully created**. In this case, backup to tape starts when the cloning process finishes, but not later than after the specified number of minutes. This helps prevent degradation of the application system performance during backup by reducing the concurrent load on the disk array.

6. If you have selected Mirrorclone as the snapshot source, under Mirrorclone synchronization handling, specify the options for handling local replication links between original volumes and mirrorclones during ZDB sessions.

For information, see "[Backup options](#)" on page 44 or press **F1**.

7. Under Replica management options, specify a value for **Number of replicas rotated**. The number of standard snapshots or vsnaps that can exist for a specific source volume is limited by the target P6000 EVA Array storage system. The GUI does not limit the number of replicas rotated, but the session fails if the disk array-specific limit is exceeded.

ZDB to disk, ZDB to disk+tape:

Select the option **Track the replica for instant recovery** to enable instant recovery.

Note: You can choose a ZDB-to-disk session or a ZDB-to-disk+tape session by selecting an appropriate value for the **Split mirror/snapshot backup** option when running or scheduling a ZDB session based on this ZDB backup specification. See "[Scheduling ZDB sessions](#)" on

page 228.

ZDB to tape:

Leave the option **Track the replica for instant recovery** cleared.

To preserve the replica on the disk array after the ZDB session, leave the option **Keep the replica after the backup** selected. To remove the replica after the session, clear this option.

8. Specify other zero downtime backup options as desired. For information, see "[Backup options](#) " on page 44 or press **F1**.

Click **Next**.

9. Select the desired backup objects.

Filesystem backup: Expand the application system and select the objects to be backed up. Note that all drive letters or mount points that reside on the system are displayed. You must select only the objects that reside on the disk array, otherwise the ZDB session will fail.

To ensure that instant recovery succeeds and the environment is consistent after instant recovery, select all volumes on a disk (Windows systems) or all logical volumes of a volume group (UNIX systems) to be backed up. Even if you do not select an entire disk or volume group, the backup will succeed, but instant recovery may experience issues during configuration check of the environment.

The configuration check can be disabled by clearing the option **Check the data configuration consistency** in the GUI or not specifying the option `-check_config` in the CLI when preparing for an instant recovery session. If this option is cleared (GUI) or not specified (CLI), the entire disk or volume group will be overwritten during instant recovery.

Click **Next**.

Disk image backup: Click **Next**.

10. Select devices. Click **Properties** to set device concurrency, media pool, and preallocation policy. For descriptions of these options, click **Help**.

To create additional copies (mirrors) of the backup image, specify the desired number of mirrors by clicking **Add mirror** or **Remove mirror**. Select separate devices for the backup image and each mirror.

For information on object mirroring, see the *HPE Data Protector Help* index: "object mirroring".

Note: Object mirroring and object copying are not supported for ZDB to disk.

Click **Next**.

11. In the Backup Specification Options group box, click **Advanced** and then the **HPE P6000 EVA SMI-S** tab to open the P6000 EVA Array backup options pane.

You can specify Application system options and modify all other options, except **Application system** and **Backup system** (note that you can change them after you save the ZDB backup specification). See "[Backup options](#) " on page 44 or press **F1**.

In the Filesystem Options group box, click **Advanced** and specify filesystem options as desired. For information, press **F1**.

Windows systems: To configure a ZDB backup specification for incremental ZDB sessions, select the **Do not use archive attribute** filesystem option in the WinFS Options pane to enhance the incremental ZDB behavior. For details, see "[Backup options](#) " on page 44.

Click **Next**.

12. Following the wizard, open the scheduler to schedule the ZDB sessions. For more information, see "[Scheduling ZDB sessions](#)" on page 228 or press **F1**.

Click **Next**.

13. In the **Backup Object Summary** page, specify additional options.

Filesystem backup: You can modify options for the listed objects by right-clicking an object and then clicking **Properties**. For information on the object properties, press **F1**.

Disk image backup: Follow the steps:

- a. Click **Manual add** to add disk image objects.
- b. Select **Disk image object** and click **Next**.
- c. Select the client system. Optionally, enter the description for your object. Click **Next**.
- d. Specify General Object Options and Advanced Object Options. For information on these options, press **F1**.
- e. In the Disk Image Object Options window, specify disk image sections.

Windows systems:

Use the format

```
\\.\PHYSICALDRIVE#
```

where # is the current number of the disk to be backed up.

For information on how to identify current disk numbers (physical drive numbers), see the *HPE Data Protector Help* index: "disk image backups".

UNIX systems:

Specify a disk image section:

```
/dev/rdisk/FileName, for example: /dev/rdisk/c2t0d0
```

On HP-UX 11.31 systems, the new naming system can be used:

```
/dev/rdisk/disk#, for example /dev/rdisk/disk2
```

Specify a raw logical volume section:

```
/dev/vgnumber/r1volNumber, for example: /dev/vg01/r1vol1
```

To ensure that instant recovery succeeds and the environment is consistent after instant recovery, select all volumes on a disk (Windows systems) or all logical volumes of a volume group (UNIX systems) to be backed up. Even if you do not select an entire disk or volume group, the backup will succeed, but instant recovery may experience issues during configuration check of the environment.

The configuration check can be disabled by clearing the option **Check the data configuration consistency** in the GUI or not specifying the option `-check_config` in the CLI when preparing for an instant recovery session. If this option is cleared (GUI) or not specified (CLI), the entire disk or volume group will be overwritten during instant recovery.

- f. Click **Finish**.

Click **Next**.

14. Save your ZDB backup specification.

For information on scheduling ZDB sessions and starting interactive ZDB sessions, see "[Scheduling ZDB sessions](#)" on page 228.

Note: Backup preview is not supported.

Backup options

The following tables describe the P6000 EVA Array and ZDB related backup options. See also "[P6000 EVA Array integration](#)" on page 258.

Client systems

Client Systems	Description
Application system	The system on which the application runs. In cluster environments, specify the virtual server hostname (rather than the physical node hostname).
Backup system	The system to which your data will be replicated (backed up). In ZDB-to-disk+tape and ZDB-to-tape sessions, the backup data is copied from this system to a backup device.

Replication mode

Replication Mode	Description
HPE Business Copy P6000 EVA	Select this option to configure a ZDB backup specification for HPE Business Copy (BC) P6000 EVA environments. Default: selected.
HPE Continuous Access P6000 EVA + HPE Business Copy P6000 EVA	Select this option to configure a ZDB backup specification for combined HPE Continuous Access + Business Copy (CA+BC) P6000 EVA environments. Default: not selected.
Follow direction of replication	This option is only available if HPE Continuous Access P6000 EVA + HPE Business Copy P6000 EVA is selected as the P6000 EVA Array configuration. Select to follow the replication direction and create replicas on the disk array remote to the current source. After a failover, the replication direction is reversed and the replicas are created on the disk array that was originally a source P6000 EVA Array storage system. Default: selected.
Maintain replica location	This option is only available if HPE Continuous Access P6000 EVA + HPE Business Copy P6000 EVA is selected as the P6000 EVA Array configuration.

Replication Mode	Description
	<p>Select to maintain replica location and create replicas on the disk array remote to home. After a failover, replicas will continue on the destination disk array that became the source P6000 EVA Array storage system during the failover.</p> <p>Default: not selected.</p>

Snapshot management options

Snapshot Management	Description		
Snapshot source	<p>This option offers two choices:</p> <ul style="list-style-type: none"> Original volume Select this choice to create snapshots of the selected storage volumes. Note that the ZDB session fails if mirrorclones of the selected storage volumes (original volumes) exist on the disk array when the session is started. If this snapshot source is selected, the options At the start of the session and At the end of the session are not available. Mirrorclone Select this choice to create snapshots of mirrorclones of the selected storage volumes. If no mirrorclones of the selected storage volumes (original volumes) exist when the ZDB session is started, Data Protector automatically creates them. Note that the ZDB session fails if snapshots of the original volumes exist on the disk array when the session is started. If this snapshot source is selected, the Snapclone snapshot type is not available. Default: Original volume. 		
Snapshot type	Vsnap (default)	Creates snapshots without the pre-allocation of disk space.	<p>If source volumes used in the session have existing target volumes of a different type (more specifically, vsnap or standard snapshot), the session is aborted. To successfully create a replica of a different type, first delete the existing target volumes.</p> <p>For more information on snapshot types, see the <i>HPE Data Protector Concepts Guide</i>.</p>
	Standard snapshot	Creates snapshots with the pre-allocation of disk space.	
	Snapclone	Creates clones of the source volumes. This snapshot type is only available if Original volume is selected as the snapshot source.	

Snapshot Management	Description
<p>Redundancy level</p>	<p>Select the storage redundancy level (Vraid type) to be used for the target volumes, or specify that the same redundancy level as for the source volumes should be used. If you create standard snapshots or vsnaps, the selected redundancy level should be the same or lower than the one used for the source volumes. Otherwise, the same redundancy level as used for the source volumes is applied. The redundancy level is checked for each source volume separately.</p> <p>The storage redundancy level and consequently the storage reliability of volumes using different Vraid types decreases as follows:</p> <p>Vraid6</p> <p>Vraid1</p> <p>Vraid5</p> <p>Vraid0</p> <p>NOTE:</p> <p>Target volumes using Vraid6 can only be created in an enhanced P6000 EVA disk group. If Vraid6 target volumes are in a basic P6000 EVA disk group, the effective Vraid type is reverted to Vraid5.</p> <p>Note that this options does not apply to mirrorclones. The mirrorclones that are automatically created during the Data Protector ZDB sessions always use the storage redundancy level of the source volumes (original volumes).</p> <p>Default: Same as source.</p>
<p>Delay the tape backup by a maximum of <i>n</i> minutes if the snapclones are not fully created</p>	<p>This option is only available if Snapclone is selected as the snapshot type.</p> <p>Prevents degradation of the application data access times and reduces the load on the disk array by delaying the operation of copying the data to tape until the cloning process completes (ZDB to tape, ZDB to disk+tape). Defines also the maximum waiting time. When the specified time is reached, backup to tape starts in any case (even if the cloning process has not finished yet).</p> <p>Default: selected, 90 minutes.</p>

Mirrorclone synchronization handling

Mirror clone sync handling	Description
<p>At the start of the session</p>	<p>Replication links between original storage volumes and their mirrorclones can be in different states. For Data Protector to be able to create a mirrorclone snapshot, the replication link between the mirrorclone and the corresponding original storage volume must be in the “synchronized” state.</p>

Mirror clone sync handling	Description
	<p>This option offers two choices:</p> <ul style="list-style-type: none"> Synchronize if fractured Select this choice to enable running the ZDB session even when the replication link between a storage volume selected in the ZDB backup specification and its mirrorclone is fractured at the start of the session. In this case, Data Protector restores the synchronized state of each such replication link before a mirrorclone snapshot creation starts. Abort if fractured Select this choice to make Data Protector abort the ZDB session in circumstances when the replication link between a storage volume selected in the ZDB backup specification and its mirrorclone is in the fractured state. If this choice is selected, the Synchronize choice for the At the end of the session option is automatically selected, and the Leave fractured choice is not available. <p>Default: Synchronize if fractured.</p>
<p>At the end of the session</p>	<p>This option determines how Data Protector handles the mirrorclone replication links after the ZDB session. It offers two choices:</p> <ul style="list-style-type: none"> Synchronize Select this choice to make Data Protector restore the “synchronized” state of replication links between the mirrorclones involved in the ZDB session and the corresponding original volumes after the mirrorclone snapshot creation. Selecting this choice has an advantage over selecting the Synchronize if fractured choice for the At the start of the session option. The reason is that the time required for synchronization is usually much shorter if synchronization takes place immediately after the mirrorclone snapshots are created, and not only before creating the mirrorclone snapshots in the next ZDB session. Leave fractured Select this choice to make Data Protector leave replication links between the mirrorclones involved in the ZDB session and the corresponding original volumes in the “fractured” state after the mirrorclone snapshot creation. If this choice is selected, the Synchronize if fractured choice for the At the start of the session option is automatically selected, and the Abort if fractured choice is not available. <p>Default: Synchronize.</p>

Replica management options

Replica Management Options	Description
<p>Keep the replica after the backup</p>	<p>If configuring a ZDB to tape, select this option to keep the replica on the disk array after the zero downtime session. The replica becomes part of a replica set (specify a value for the option Number of replicas rotated). Unless the additional option Track the replica for instant recovery is selected, the replica is <i>not</i> available for instant recovery.</p> <p>If this option is not selected, the replica is removed at the end of the session.</p> <p>If the option Track the replica for instant recovery is selected, this option is automatically selected and cannot be changed.</p> <p>Default: selected.</p>
<p>Number of replicas rotated</p>	<p>This option is only available if the option Keep the replica after the backup is selected.</p> <p>During ZDB sessions, Data Protector creates a new replica and leaves it on the disk array until the value specified for the option Number of replicas rotated is reached. After that, the oldest replica is deleted and a new one created.</p> <p>The number of standard snapshots or vsnaps is limited by the P6000 EVA Array storage system. Data Protector does not limit the number of replicas rotated, but the session fails if the limit is exceeded.</p> <p>Default: 1.</p>
<p>Track the replica for instant recovery</p>	<p>This option is only available if the option Keep the replica after the backup is selected.</p> <p>Select this option to perform a ZDB-to-disk or ZDB-to-disk+tape session and leave the replica on the disk array to enable instant recovery. Specify also a value for the option Number of replicas rotated.</p> <p>If this option is not selected, you cannot perform instant recovery using the replica created or reused in this session.</p> <p>Default: not selected.</p>

Application system options

Application System Options	Description
<p>Dismount the filesystems on the application system before replica generation</p>	<p>Select this option to dismount the filesystems on the application system before replica creation and remount them afterwards. Additionally, when entire physical drives (on Windows systems) or entire disks or logical volumes (on UNIX systems) are selected as backup objects in a disk image backup specification, selecting this option will dismount and later remount all filesystems on these objects. If any of these filesystems cannot be dismounted, the backup session fails.</p> <p>If an integrated application (for example, Oracle Server) exclusively controls data I/O on each physical drive, disk, or logical volume that will be backed up, the dismount operation is not needed. In such a case, you can leave this option cleared.</p> <p>Default: not selected.</p>
<p>Stop/quiesce the application command line</p>	<p>If a command is specified in this option, it is invoked on the application system immediately before replica creation. An example is to stop applications not integrated with Data Protector.</p> <p>The command must reside on the application system in the default Data Protector administrative commands directory. Do not specify the path to the command in this option.</p> <p>If the command fails, the command specified in the option Restart the application command line is not invoked. Thus, you may need to implement a cleanup procedure in the command specified in Stop/quiesce the application command line. If the <code>omnicrc</code> option <code>ZDB_ALWAYS_POST_SCRIPT</code> is set to 1, the command specified in the option Restart the application command line is always invoked.</p>
<p>Restart the application command line</p>	<p>If a command is specified in this option, it is invoked on the application system immediately after replica creation. An example is to resume operation of applications not integrated with Data Protector.</p> <p>The command must reside on the application system in the default Data Protector administrative commands directory. Do not specify the path to the command in this option.</p>

Backup system options

Backup System Options	Description
<p>Use the same mountpoints as on the application system</p>	<p>This option is not available if the application system is also the backup system (a single-host configuration).</p>

Backup System Options	Description
	<p>If this option is selected, the paths to mount points used for mounting the filesystems of the replica on the backup system are the same as paths to mount points where source volume filesystems were mounted on the application system.</p> <p>If the mount points are already in use, the session fails. For such circumstances, you must select the option Automatically dismount the filesystems at destination mountpoints in order for the session to succeed.</p> <p>Windows systems: The drive letters must be available, otherwise the session fails.</p> <p>Default: not selected.</p>
<p>Root of the mount path on the backup system</p>	<p>This option is only available if the option Use the same mountpoints as on the application system is not selected.</p> <p>Specifies the root directory under which the filesystems of the replica are mounted.</p> <p>Where exactly the filesystems are mounted depends on how you define the option Add directories to the mount path.</p> <div data-bbox="607 1014 1365 1136" style="background-color: #f0f0f0; padding: 5px;"> <p>Note: For the SAP R/3 integration, the option is not applicable (the mount points created are always the same as on the application system).</p> </div> <p>Defaults:</p> <p>Windows systems: c:\mnt</p> <p>UNIX systems: /mnt</p>
<p>Add directories to the mount path</p>	<p>This option is only available if the option Use the same mountpoints as on the application system is not selected.</p> <p>This option enables control over the created mount points. It defines which subdirectories will be created in the directory defined with the Root of the mount path on the backup system option. When Session ID is used in path composition, this guarantees unique mount points.</p> <p>Example for Windows systems:</p> <p>Root directory: C:\mnt</p> <p>Application system: app1sys.company.com</p> <p>Backup session ID: 2008-02-22-4</p> <p>Mount path on the application system: E:\disk1</p> <p>If Hostname is selected:</p>

Backup System Options	Description
	<p>C:\mnt\applsys.company.com\E\disk1</p> <p>If Hostname and session ID is selected:</p> <p>C:\mnt\applsys.company.com\2008-02-22-4\E\disk1</p> <p>If Session ID is selected:</p> <p>C:\mnt\2008-02-22-4\E\disk1</p> <p>If Session ID and hostname is selected:</p> <p>C:\mnt\2008-02-22-4\applsys.company.com\E\disk1</p> <div style="background-color: #f0f0f0; padding: 5px; margin: 10px 0;"> <p>Note: For the SAP R/3 integration, the option is not applicable (the mount points created are always the same as on the application system).</p> </div> <p>Default: Hostname and session ID.</p>
<p>Automatically dismount the filesystems at destination mountpoints</p>	<p>If the mount points are in use (for example, volumes involved in the previous session may still be mounted) and this option is selected, Data Protector attempts to dismount the mounted filesystems.</p> <p>If the option is not selected and the mount points are in use, or if the option is selected and the dismount operation fails, the session fails.</p> <p>Default: not selected.</p>
<p>Leave the backup system enabled</p>	<p>This option is only available if the option Keep the replica after the backup is selected.</p> <p>If this option is selected, the filesystems remain mounted, the volume groups remain imported and active (UNIX systems), and the target volumes remain presented after the session. In this case, you can use the backup system for data warehousing purposes, but <i>not</i> for instant recovery. If the replica has to be reused later on (deleted, rotated out, or used for instant recovery), Data Protector automatically connects to the backup system, dismounts the filesystems, unrepresents the target volumes, and clears the related logical structures on the backup system. At that point in time, if the filesystems are not mounted to the current backup system, Data Protector cannot perform a proper cleanup, and aborts the operation or the instant recovery session.</p> <p>If this option is not selected, Data Protector dismounts filesystems, exports volume groups (UNIX systems), and unrepresents the target volumes on the backup system at the end of the ZDB session.</p> <p>Default: selected.</p>

Backup System Options	Description
<p>Enable the backup system in read/write mode</p>	<p>This option is applicable to and can only be changed for UNIX systems only. On Windows systems, filesystems cannot be mounted in the read-only mode.</p> <p>Select this option to enable write access to volume groups and filesystems on the backup system. For backup purposes, it is sufficient to activate the backup system volume groups and mount the filesystems in the read-only mode. For other tasks, the read/write mode may be needed.</p> <p>Note that when this option is selected, the replica is open to modifications while the backup system is online. Consequently, data restored from such a replica includes all potential modifications.</p> <p>Defaults:</p> <p>Windows systems: selected.</p> <p>UNIX systems: not selected.</p>

Note: In a particular ZDB session, the mount point paths to which filesystems of the replica are mounted on the backup system correspond the mount point paths to which source volumes were mounted on the application system if at least one of the following conditions is met:

- The GUI option **Use the same mountpoints as on the application system** is selected.
- The `omnirc` option `ZDB_PRESERVE_MOUNTPOINTS` is set to 1.

If the option **Use the same mountpoints as on the application system** is not selected, and the `omnirc` option `ZDB_PRESERVE_MOUNTPOINTS` is set to 0, the mount point paths are determined by the GUI options **Root of the mount path on the backup system** and **Add directories to the mount path**, and the `omnirc` options `ZDB_MULTI_MOUNT` and `ZDB_MOUNT_PATH` are ignored.

Charts below provide detailed backup flows according to the backup options selected.

ZDB-to-disk session flow for filesystem backup objects

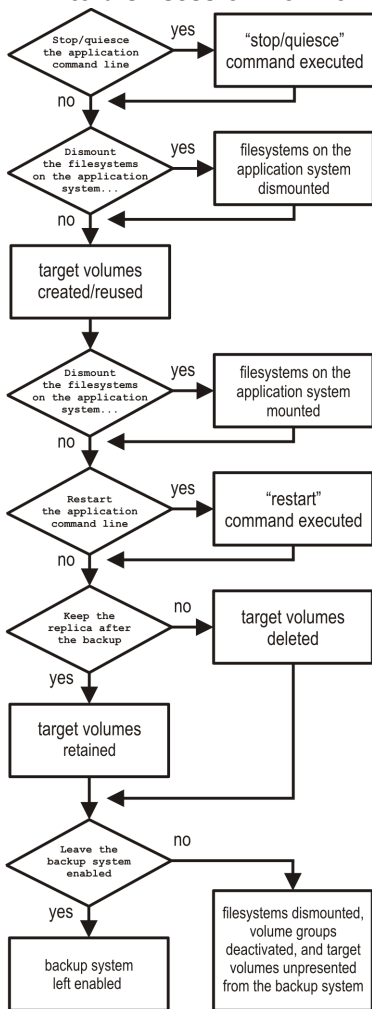

ZDB-to-tape and ZDB-to-disk+tape session flow for filesystem backup objects

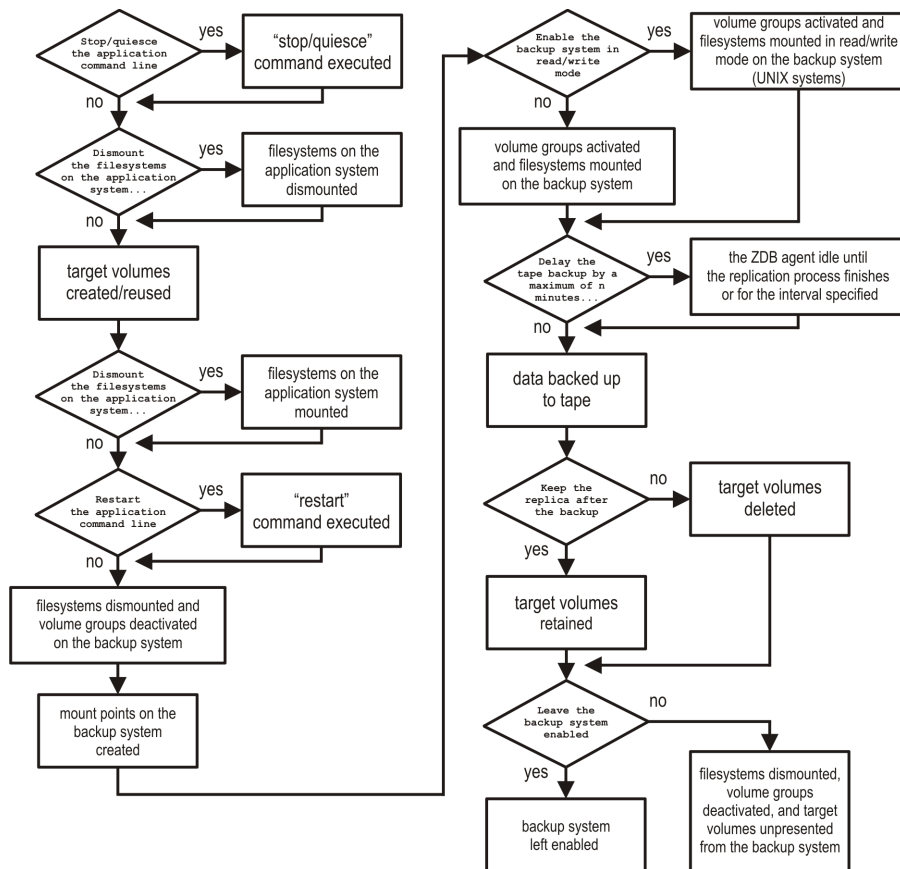

- “Reuse” means that target volumes from the oldest replica are deleted and a new replica is created.
- Due to an HPE P6000 EVA Disk Array Family limitation, if a standard snapshot or vsnap exists on a disk array for a particular source volume, creation of another target volume of some other snapshot type fails, even if a different ZDB specification is used. To enable the creation of such a target volume, existing standard snapshots or vsnaps of the source volume must be deleted first.
- In ZDB-to-disk sessions, the backup option **Enable the backup system in read/write mode** is ignored.
- When configuring a ZDB backup specification for ZDB-to-tape sessions, you can select the option **Keep the replica after the backup**. When configuring a ZDB backup specification for ZDB-to-disk+tape sessions, this option is selected by default and cannot be deselected.

Chapter 7: Restore

Introduction

This chapter describes configuring and running a filesystem or disk image restore of the data backed up using the P6000 EVA Array integration. The sections describe restore procedures using the Data Protector GUI and CLI.

The data backed up in a ZDB session can be stored on a disk array only (ZDB to disk), on backup media only (ZDB to tape), or at both locations (ZDB to disk+tape).

Available restore types are:

- Restore from backup media on a LAN (standard restore). See ["Standard restore" below](#).
- Instant recovery. See ["Restore " above](#).

Restore types

	Standard restore	Instant recovery
ZDB to disk	N/A	Yes
ZDB to disk+tape	Yes	Yes
ZDB to tape	Yes	N/A

Standard restore

Data backed up in ZDB-to-tape and ZDB-to-disk+tape sessions can be restored from the backup media to the application system. For more information on this restore type, see the *HPE Data Protector Help* index: "restore".

Tip: You can improve the data transfer rate by connecting a backup device directly to the application system. For information on configuring backup devices, see the *HPE Data Protector Help* index: "backups devices: configuring". For information on performing a restore using another device, see the *HPE Data Protector Help* index: "selecting, devices for restore".

Instant recovery

Instant recovery restores data directly from a replica to source volumes, without involving a backup device. All data in the replica is restored, including filesystems or other objects which were not explicitly selected for backup. For instant recovery concepts, see the *HPE Data Protector Concepts Guide*.

You can perform instant recovery using:

- The Data Protector GUI
See "[Instant recovery using the GUI](#)" on page 59.
- The Data Protector CLI
See "[Instant recovery using the CLI](#)" on page 62.

The number of replicas available for instant recovery is limited by the value of the option **Number of replicas rotated**, which determines the size of the replica set. You can view these replicas in the GUI in the Instant Recovery context by expanding Restore Sessions. Replicas are identified by the backup specification name and the session ID. Other information, such as time when the replica was created, is also provided. Alternately, you can use the Data Protector command `omnidbsmis` to list sessions. For more information, see the *HPE Data Protector Command Line Interface Reference* or the `omnidbsmis` man page.

When instant recovery starts, Data Protector disables the application system. This includes dismounting filesystems and deactivating or exporting volume groups (UNIX). Before this is done, filesystems' and volume groups' status is checked, and only mounted filesystems are dismounted and active volume groups are deactivated or exported. At the end of the session, volume groups are reactivated and dismounted filesystems are mounted to the same mount points as were used during backup.

Limitations

- Instant recovery fails in the following situations:
 - The source volumes do not exist on the disk array any more.
 - The source volumes are not presented to the application system.
 - If the current configuration of the participating volumes (on Windows systems) or volume groups (on UNIX systems) is different from the volume/volume group configuration that existed at the time of the ZDB session and which was recorded in the SMISDB.
 - After instant recovery, restored filesystems are mounted to the same mount points or drive letters on the application system as they were at the backup time, but these mount points or drive letters have other filesystems mounted.
- While an instant recovery session is in progress, you cannot perform a zero downtime backup session that involves the source volumes to which the data is being restored.

For the P6000 EVA Array instant recovery-related limitations and considerations, see the HPE Data Protector Product Announcements, Software Notes, and References and the *HPE Data Protector Concepts Guide*.

Instant recovery methods

Depending on the snapshot type of the selected replica and the instant recovery options you select in the GUI or CLI, instant recovery can be performed using one of the following methods:

- by switching the disks
This instant recovery method (also referred to as the "switch" method) is available only for replicas which consist of snapclones.

- by copying replica data and retaining the source volumes
This instant recovery method (also referred to as the “copy-back” method) is available for replicas of any snapshot type.
- by copying replica data without retaining the source volumes
This instant recovery method (also referred to as the “copy-back” method) is available for replicas of any snapshot type.

Switching the disks

With this instant recovery method, the source volumes are unrepresented and the target volumes (replica from the selected session) are presented in the place of the source volumes. During this action, which is called identity exchange, information such as the volume names and comments are also exchanged between the source and target volumes. You can select to retain the old source volumes. However, you cannot retain the replica and cannot perform another instant recovery using the same backup data.

This method may change the physical location of the application data in production. After instant recovery, target volumes become the source volumes, therefore, the performance characteristics of the replica now become the characteristics of the application data. The application starts using the physical disks that were previously used for storing backup data.

Advantages

- Instant recovery is very fast, regardless of the amount of data that was backed up.
- The old source volumes can be retained after instant recovery.

Disadvantages

- It is not possible to perform another instant recovery using the same backup data, because the target volumes have become the new source volumes.
- If a replica to be used for instant recovery belongs to a different disk group than its source volumes, the disk group of the replica becomes the disk group of the source volumes after the instant recovery session. In this case, depending on the target disk group characteristics, the source storage volume performance may decrease.
- Storage reliability of the source storage volumes may decrease if the replica to be used for instant recovery has a lower redundancy level.

To perform this type of instant recovery, select the option **Switch to the replica** in the Data Protector GUI.

Copying replica data and retaining the source volume

With this instant recovery method, the process depends on the snapshot type used for the target volumes:

- If the target volumes are standard snapshots or vsnaps, new snapshots of the source volumes are created inside the same P6000 EVA disk group first, and the source volumes are overwritten with data from the existing replica afterwards. Original data is retained in the newly created snapshots.
- If the target volumes are snapclones, containers are created in the disk group of the source volumes first, the data from the existing replica is restored to the containers, and finally the source volumes are switched with the containers.

The replica is also retained in the replica set and another instant recovery using the same backup data can be run.

Note: If snapshots of mirrorclones were created in the ZDB session, during instant recovery, data from mirrorclone snapshots is restored directly to the corresponding original volumes.

Advantages

- Another instant recovery using the same backup data is possible.
- The old source volumes are retained after instant recovery.
- The performance characteristics of the restored volumes remain the same. This is because the physical disks and the characteristics of the source storage volumes (size, storage redundancy level) do not change.

Disadvantages

- Instant recovery is not as fast as with the "switching the disks" method.
- Instant recovery requires additional storage space in the disk group of the source volumes.
- When a replica that consists of standard snapshots or vsnaps is used, if newer replicas than the selected replica exist in the replica set, the instant recovery process lasts longer because not only the source volumes, but all newer replicas must be updated during the session as well.

To perform this type of instant recovery, select the options **Copy replica data to the source location** and **Retain source for forensics** in the Data Protector GUI.

Copying replica data without retaining the source volume

With this instant recovery method, the source volumes are directly overwritten with data from the replica. If the replica consists of snapclones, the source volumes are converted into containers before being overwritten. The source volumes are not retained and if the instant recovery session fails, the original application data residing on the source volumes is lost.

The replica is retained in the replica set and another instant recovery using the same backup data can be run.

Note: If snapshots of mirrorclones were created in the ZDB session, during instant recovery, data from mirrorclone snapshots is restored directly to the corresponding original volumes.

Advantages

- Another instant recovery using the same backup data is possible.
- The performance characteristics of the restored volumes remain the same. This is because the physical disks and the characteristics of the source storage volumes (size, storage redundancy level) do not change.
- No additional storage space is required for instant recovery.

Disadvantages

- Instant recovery is not as fast as with the "switching the disks" method.
- Data in the source volumes is lost during instant recovery.

- If the instant recovery session fails, the original data in the source volumes to be restored is lost.
- When a replica that consists of standard snapshots or vsnaps is used, if newer replicas than the selected replica exist in the replica set, the instant recovery process lasts longer because not only the source volumes, but all newer replicas must be updated during the session as well.

To perform this type of instant recovery, select the option **Copy replica data to the source location** and clear the option **Retain source for forensics** in the Data Protector GUI.

Instant recovery procedure

Prerequisites

- Target volumes used in an instant recovery session should not be presented to any system other than the backup system. You can make Data Protector automatically remove any disallowed target volume presentations by selecting the option **Force the removal of all replica presentations** in the GUI or by specifying the `omnir` option `-force_prp_replica` in the CLI.
- If a disk image backup with filesystems mounted on the selected disks was performed, manually dismount the filesystems on the disks to be restored before disk image instant recovery. If the option **Check the data configuration consistency** is cleared in the GUI or the `omnir` option `-check_config` is not specified in the CLI, the disks are dismounted automatically. In any case, re-mount the filesystems back after instant recovery.
- In HPE Continuous Access + Business Copy (CA+BC) P6000 EVA environments, if the source volumes are included in a data replication (DR) group, instant recovery requires prior manipulation of the DR group and other steps that need to be followed before and after the instant recovery session. For details, see ["Instant recovery for in CA+BC configurations" on page 240](#).

Considerations

- If mirrorclones were used in the corresponding zero downtime backup session, in an instant recovery session the data from the replica is restored directly to the original volumes.

Instant recovery using the GUI

Follow the steps:

1. In the Context List, select **Instant Recovery**.
2. In the Results Area, select the backup session (replica) from which you want to perform the recovery. This can be done by selecting:
 - Backup session ID and name (in the Scoping Pane, expand **Restore Sessions** and select a session from the list of ZDB-to-disk and ZDB-to-disk+tape sessions)
 - Backup object type (Filesystem, Disk Image, SAP R/3, ...) and backup session name and ID:
 - i. In the Scoping Pane, expand **Restore Objects**.
Backed up object types are displayed.
 - ii. Expand the object type you want to restore.
All available backup specification used in ZDB-to-disk or ZDB-to-disk+tape sessions for the selected object type are displayed.

- iii. Expand the backup specification containing the replica set. Available sessions IDs (replicas) are displayed.

Selecting a session

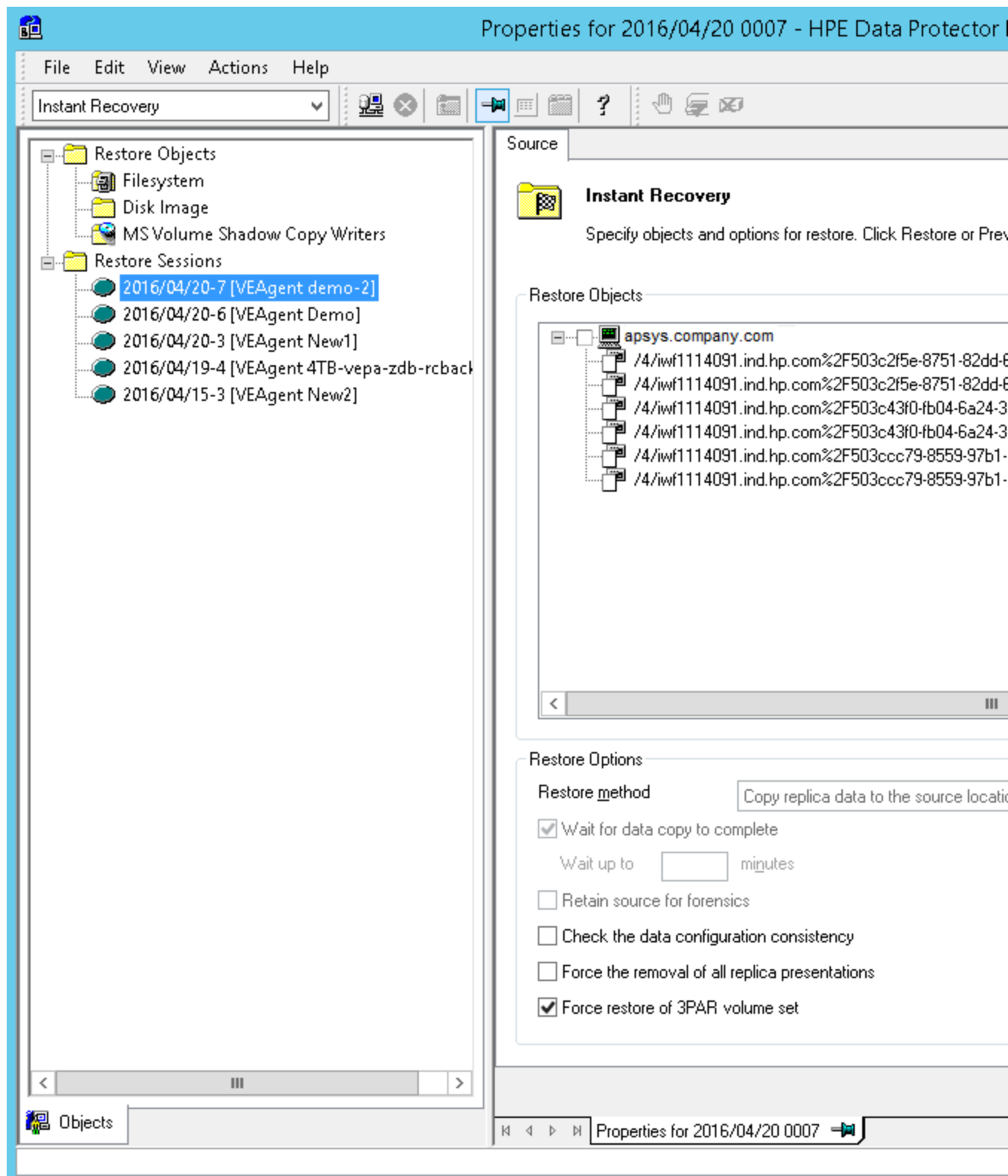

3. In the Scoping Pane, click the backup session (replica) you want to restore.

The application system and its mount points or drive letters representing source volumes backed up during the selected session are displayed. Note that on UNIX all logical volumes inside a volume group and on Windows all partitions on a disk were backed up and if you did not select them all, they are not displayed here.

4. Check the selection box next to the application system to select the session for restore. You cannot select sub-components because instant recovery restores the complete replica.
5. Specify other instant recovery options as desired. For information, see ["Selecting a session " on the previous page](#) and ["Instant recovery options" below](#), or press **F1**.
6. Click **Restore** to start the instant recovery session or **Preview** to start the instant recovery preview.

You cannot use the Data Protector GUI to perform instant recovery using backup data created in a ZDB-to-disk+tape session after the media used in the session has been exported or overwritten. In such circumstances, use the Data Protector CLI instead. Note that the backup media must not be exported or overwritten even after an object copy session.

Instant recovery using the CLI

1. List all available ZDB-to-disk or ZDB-to-disk+tape sessions (identified by the session ID):

```
omnidbsmis -list -session -ir
```

From the output, select the backup session you want to restore.

2. Run the following command:

```
omnir -host ClientName -session SessionID -instant_restore [INSTANT_RECOVERY_OPTIONS]
```

where the meaning of the options is as follows:

ClientName Application system name.

SessionID Backup session ID ("[List all available ZDB-to-disk or ZDB-to-disk+tape sessions \(identified by the session ID\):" above](#) of this procedure).

For *INSTANT_RECOVERY_OPTIONS*, see ["Instant recovery options " below](#).

For details, see the *HPE Data Protector Command Line Interface Reference* or the *omnidbsmis* and *omnir* man pages.

Instant recovery options

Instant recovery options

Data Protector GUI/CLI	Function	
Restore method	Copy replica data to the source location / -copyback	Select this method to copy the replica data of the specified ZDB session to the original storage as follows: <ul style="list-style-type: none"> • With the Retain source for forensics option selected in the GUI or with the option -leave_

Data Protector GUI/CLI	Function	
		<p>source specified in the CLI, the process depends on the snapshot type used for the target volumes.</p> <p>If the target volumes are standard snapshots or vsnaps, new snapshots of the source volumes are created inside their P6000 EVA disk group first, the data from the existing replica is restored to the source volumes afterwards. Original data is retained in the newly created snapshots.</p> <p>If the target volumes are snapclones, containers are created in the disk group of the source volumes first, the data from the existing replica is restored to the containers, and finally the source volumes are switched with the containers.</p> <ul style="list-style-type: none"> • With the Retain source for forensics option not selected in the GUI or with the option <code>-no_leave_source</code> specified in the CLI, the data from the existing replica is restored to the source volumes without prior operations. <p>Caution: If the instant recovery session fails, a data loss on the source volumes may occur.</p> <p>Note: If mirrorclones were used in the corresponding zero downtime backup session, the term “source volumes” as used in both described cases refers to the original volumes, not the mirrorclones.</p> <p>After the instant recovery session, the replica is not deleted from the replica set, and the information about it is not deleted from the SMISDB. Therefore, the replica is available for another instant recovery session until it is rotated out from the replica set or deleted manually.</p> <p>This instant recovery method takes about as much time as the replica creation did, but the storage redundancy level is preserved and the source volumes remain in their P6000 EVA disk group.</p> <p>Default (GUI): selected</p>
	<p>Switch to the replica / -switch</p>	<p>This method can only be selected if the target volumes created in the corresponding zero downtime backup session are snapclones.</p>

Data Protector GUI/CLI	Function
	<p>Select this method to switch the target volumes of the specified ZDB session with the corresponding source volumes. Identifiers (WWNs) of the source volumes are assigned to the target volumes and these volumes are presented in the place of the source volumes. This action is called identity exchange. After the instant recovery session, the replica is not available for another instant recovery session, and the information about it is deleted from the SMISDB. Unless the option Retain source for forensics is selected in the GUI or unless the option <code>-leave_source</code> is specified in the CLI, the source volumes are removed.</p> <p>This instant recovery method is much faster than the method of copying replica data, since no data needs to be copied. However, after the instant recovery session, the new source volumes may have a lower storage redundancy level and may be located in a different P6000 EVA disk group.</p> <p>Default (GUI): not selected.</p>
<p>Wait for the replica to complete / <code>wait_clonecopy n</code></p>	<p>This option is only available if Copy replica data to the source location is selected as the restore method in the GUI or the option <code>-copyback</code> is specified in the CLI.</p> <p>Before the actual data copy operation, storage space is allocated for replica restoration. Although the copy of the replica is only virtual at that time, it is immediately available for use. In the background, however, a process is still copying data from the replica to the source location (the replica normalization process). This copy process may degrade the disk array performance, and indirectly the application system performance as well. To reduce a potential performance degradation, select this option to make Data Protector wait for the copy to complete before proceeding with the session. In the GUI, you can set the maximum delay with the option Wait up to <i>n</i> minutes.</p> <p>Additionally, you can control the copy process by setting appropriate <code>omnirc</code> option. See "P6000 EVA Array and 3PAR StoreServ Storage specific options" on page 250.</p> <p>Default (GUI): not selected.</p>
<p>Wait up to <i>n</i> minutes</p>	<p>This option is only available if the option Wait for the replica to complete is selected.</p> <p>This option defines the maximum time that Data Protector waits for the</p>

Data Protector GUI/CLI	Function
	<p>replica data to be copied to the source location before proceeding with the instant recovery session. If the copy process completes before the time period expires, the session continues immediately.</p> <p>Default (GUI): 60 minutes.</p>
<p>Retain source for forensics / -leave_source -no_leave_source</p>	<p>If this option is selected in the GUI or the -leave_source option is specified in the CLI, Data Protector preserves original data from the source volumes on the disk array after instant recovery. The original data resides in the source volume snapshots in the same P6000 EVA disk group as the source volumes. For example, you can use this option to investigate why the original data got corrupted.</p> <p>If this option is not selected in the GUI or the -no_leave_source option is specified in the CLI, the source volumes are either overwritten with data from the replica (with the “copy-back” instant recovery method) or deleted (with the “switch” instant recovery method) during the instant recovery session. In case of the “copy-back” instant recovery method in which the replica used consists of snapclones, the source volumes are converted into containers before being overwritten, provided that the source and target volumes match in size, redundancy level, and belong to the same P6000 EVA disk group.</p> <p>CAUTION:</p> <p>If you decide to perform instant recovery by copying replica data and not to preserve source volumes after the session (the option Copy replica data to the source location is selected and the option Retain source for forensics is cleared), and then the instant recovery session fails, a data loss on the source volumes may occur.</p> <p>Default (GUI): selected.</p>
<p>Check the data configuration consistency / -check_config -no_check_config</p>	<p>If this option is selected in the GUI or the -check_config option is specified in the CLI, Data Protector performs a sanity check and a comparison of current volume group configuration of the volume groups participating in the instant recovery session and the volume group configuration information kept in the SMISDB after the corresponding zero downtime backup session. If the sanity check fails or the volume group configuration has changed since the zero downtime backup session, the instant recovery session aborts.</p> <p>Additionally, if the "switch" restore method is chosen and this option is selected for an instant recovery session, and storage redundancy levels of a particular target volume in the replica and its corresponding source volume differ, the session fails.</p> <p>MC/ServiceGuard clusters: When performing instant recovery to some other node than the one from which data was backed up, you must select</p>

Data Protector GUI/CLI	Function
	<p>this option in the GUI or specify the <code>-check_config</code> option in the CLI. In such circumstances, the current volume group configuration on the node to which data is to be restored differs from the volume group configuration kept in the SMISDB. Consequently, the SMISDB volume group configuration data is replaced by the current volume group configuration data on the node to which data is to be restored, and the instant recovery session succeeds.</p> <p>Default (GUI): selected.</p>
<p>Force the removal of all replica presentations / <code>-force_prp_replica</code></p>	<p>If this option is selected in the GUI or specified in the CLI, and a target volume containing data to be restored is presented to a system other than the backup system, the HPE P6000 / HPE 3PAR SMI-S Agent removes such presentation. If the option is not selected in the GUI or not specified in the CLI, the instant recovery session fails in such circumstances.</p> <p>If this option is selected in the GUI or specified in the CLI, and any target volume containing data to be restored is presented to the backup system, but cannot be dismounted in an operating system-compliant way, the HPE P6000 / HPE 3PAR SMI-S Agent performs a forced dismount. If the option is not selected in the GUI or not specified in the CLI, the instant recovery session fails in such circumstances.</p> <p>Default (GUI): not selected.</p>

Instant recovery in HPE CA+BC P6000 EVA configurations

You can perform instant recovery to restore the data backed up in HPE CA+BC P6000 EVA configurations. For detailed information, see ["Instant recovery for in CA+BC configurations" on page 240](#).

Instant recovery and LVM mirroring

Method 1 – instant recovery with reducing and extending the mirrors

Using this method, you reduce the mirrors to include only the PVG from which the backup was taken. Instant recovery is performed after the volume is reduced, and then the logical volume is mirrored again to include all PVGs.

Caution: Before reducing the mirrors, verify that the mirror which is being reduced is the correct one. Otherwise, depending on the restore options selected, irrecoverable loss of data may happen. It is recommended to record and verify mirroring settings and the output of `lvdisplay` and `vgdisplay` commands.

1. Reduce the mirrors using the `lvreduce` command. Only the mirror copy that was backed up should remain.

Example

If the VG01 volume group contains a logical volume lvo11, which contains the disks /dev/dsk/c12t0d0 and /dev/dsk/c12t0d1 (belonging to PVG-2), and /dev/dsk/c15t0d0 and /dev/dsk/c15t0d1 (belonging to PVG-1), reduce the volume to contain only disks from PVG-2:

```
lvreduce -m 0 /dev/vg01/lvo11 /dev/dsk/c15t0d0
```

```
lvreduce -m 0 /dev/vg01/lvo12 /dev/dsk/c15t0d1
```

You can also check the output using the `lvdisplay` command.

2. Perform instant recovery using the Data Protector GUI or CLI. For instructions, see ["Instant recovery procedure" on page 59](#).

Note: If the option **Check the data configuration consistency** option is selected in the GUI or the option `-check_config` is specified in the CLI, instant recovery fails, as the configuration of the volume group changed. Therefore, clear (GUI) or do not specify (CLI) this option before instant recovery.

3. Extend the mirror to include PVG-1 in the logical volume. The mirror is created again to include both volume groups.

Example

To extend the logical volume to contain two mirrors as in the original setup, execute:

```
lvextend -m 1 /dev/vg01/lvo11 /dev/dsk/c15t0d0
```

```
lvextend -m 1 /dev/vg01/lvo11 /dev/dsk/c15t0d1
```

This way, lvo11 contains the disks /dev/dsk/c15t0d0 and lvo12 contains the disks /dev/dsk/c15t0d1 as a mirrored copy.

Method 2 – instant recovery with splitting and merging the mirrors

This method uses the splitting functionality of LVM mirroring. Logical volumes are first split to create backup volumes. These backup volumes can be overwritten by the data from the replica created. Later, the backup volumes are merged back.

Caution: Before splitting the mirrors, verify that the mirror which is being split is the correct one. Otherwise, irrecoverable loss of data may happen. It is recommended to record mirroring settings and the output of `lvdisplay` and `vgdisplay` commands.

1. Split the mirrors using the `lvsplit` command. Specify the group where the replica will not be restored by checking `vgdisplay` and `lvdisplay` outputs. After the split, volumes in the PVGs are no longer in the mirror, and their backup copies are present.

Example

A volume group VG01 contains logical volumes lvo11 and lvo12, which contain the disks belonging to PVG-1 and PVG-2. To split the logical volume to contain the disks from PVG-2 only, execute:

```
lvsplit -s back -g PVG1 /dev/vg01/lvo11 /dev/vg01/lvo12
```

The disks from PGV-1 are split and a new logical volume with the suffix `back` is created. This logical (backup) volume can be accessed at `/dev/vg01/lvol1back` and `/dev/vg01/lvol2back`. You can check this using the `vgdisplay` command, which shows that another pair of logical volumes is now present in the volume group `vg01`. Similarly, the `lvdisplay` command shows that the physical disks from PVG-1 are no longer part of `lvol1` (they belong to `lvol1back`).

2. Perform instant recovery using the Data Protector GUI or CLI. For instructions, see "[Instant recovery procedure](#)" on page 59.

Note: If the option **Check the data configuration consistency** option is selected in the GUI or the option `-check_config` is specified in the CLI, instant recovery fails, as the configuration of the volume group changed. Therefore, clear (GUI) or do not specify (CLI) this option before instant recovery.

3. Merge the mirrors back to their original logical volume using the `lvmerge` command (the newly created logical volumes, which are merged back, have the `back` suffix). This way, the mirror is created again to include both volume groups.

Example

The logical volume `lvol1` was split before instant recovery. After instant recovery, execute:

```
lvmerge /dev/vg01/lvol1back /dev/vg01/lvol1  
lvmerge /dev/vg01/lvol2back /dev/vg01/lvol2
```

Instant recovery in a cluster

For information on instant recovery with an application running on or a filesystems residing in MC/ServiceGuard or Microsoft server cluster, see "[Cluster configurations](#)" on page 230.

Chapter 8: Troubleshooting

Before you begin

This chapter lists general checks and verifications plus problems you may encounter when using the P6000 EVA Array integration. For general Data Protector troubleshooting information, see the *HPE Data Protector Troubleshooting Guide*.

- Ensure that the latest official Data Protector patches are installed. For information on how to verify this, see the *HPE Data Protector Help* index: “patches”.
- For general Data Protector and integration-specific limitations, as well as recognized issues and workarounds, see the HPE Data Protector Product Announcements, Software Notes, and References.
- For an up-to-date list of supported versions, platforms, and other information, see <https://softwaresupport.hpe.com/>.

Checks and verifications

- On the application and backup systems, examine system errors logged into `debug.log` file residing in the default Data Protector log files directory.

Backup problems

Problem

You cannot select the HPE P6000 EVA SMI-S mode in the Data Protector user interface when creating a ZDB backup specification

Action

Check that the HPE P6000 / HPE 3PAR SMI-S Agent integration module is installed on the application system and the backup system. To do that, open the `cell_info` file located on the Cell Manager in the following directory:

Windows systems: `Data_Protector_program_data\Config\server\cell\cell_info`

UNIX systems: `/etc/opt/omni/server/cell/cell_info`

File contents should look similar to the following:

```
-host "sap002.company.com" -os "HPs800 hp-ux-11.00" -cc A.09.00 -da  
A.09.00 -ma A.09.00 -SMISA A.09.00
```

Problem

The HPE P6000 / HPE 3PAR SMI-S Agent fails to connect to the Cell Manager and retrieve configuration data

[Major]

Cannot connect to the Cell Server. (Insufficient permissions.
Access denied.)

The HPE P6000 / HPE 3PAR SMI-S Agent is always started as an administrator's process on the application and backup systems. Therefore, the user who starts it must be the member of **admin** or **operator** user groups.

Action

Using the GUI, check if the user is a member of **admin** or **operator** user groups. If not, add the user to one of these groups. In addition, ensure that administrators from both the application and backup systems belong to Data Protector **admin** or **operator**.

Problem

On an HP-UX system, the HPE P6000 / HPE 3PAR SMI-S Agent fails to communicate with the HPE SMI-S P6000 EVA Array provider using SSL

[Warning]

The SSL connection to the P6000 EVA Array SMI-S provider has failed.
The error description returned is:
SSL Exception: Random seed file required

On HP-UX systems, Pegasus libraries require the random number generator pseudo device for its SSL-based communication with the SMI-S P6000 EVA Array provider. If the pseudo device is not present, the warning appears.

Action

1. Install the pseudo device in `/dev/random` on the HP-UX backup system.
2. Re-run the session.

Problem

On Linux systems, `hp_rescan` fails to resolve P6000 EVA Array 3PAR storage volumes during a scan of SCSI devices

The following error is displayed:

```
[Major] From: SMISA@company.com "SMISA" Time: 10/26/2013 4:27:18 AM
```

Failed to resolve a storage volume on the host.

Action

Data Protector uses `hp_rescan` script from the `Fibreutils` for HPE Storage Fibre Channel Host Bus Adapter for Linux (HPE `fibretutils` package).

1. Verify that you have installed the correct HPE `fibretutils` package for your Linux distribution.

Run the following command:

```
rpm -qa | grep -i fibretutils
```

Example output

```
fibretutils-2.3-7.x86_64
```

If you have installed it, ensure that it is the correct version supported for your Linux distribution.

If your system is running an unsupported version, either uninstall it or update it to a supported version.

The supported version of the HPE fibretutils package for your Linux distribution can be obtained from: <http://h20565.www2.hp.com/portal/site/hpsc/>.

Problem

No HPE SMI-S CIMOM login entries are configured within SMISDB

Action

Add an HPE SMI-S CIMOM login information to SMISDB:

```
omnidbemis -ompasswd -add ClientName [-ssl] [-port PortNumber] [-user Username] [-passwd Password]
```

Problem

On a UNIX system, ZDB sessions stop responding for a long time during the resolving of the backup objects on the application system

When resolving the backup objects on the application system, Data Protector sends SCSI inquiries to identify the vendor-specific details of the virtual disk to be replicated. If this virtual disk belongs to a DR group that is in the "failsafe-locked" mode, SCSI inquiries do not return at all. As a result, the session stops responding.

Action

1. Abort the session and stop the ZDB agent processes that stopped responding on the application system.
2. Identify the root cause for the "failsafe-locked" mode of the DR group and fix it by bringing the DR group back into normal operational mode.

Problem

On the application system, dismounting a filesystem fails

Action

Ensure that no other processes use the filesystem to be dismounted. If `Stop/quiesce the application command line` was specified, check that it stops all processes using the filesystem.

Problem

On a Windows system, replica cannot be mounted to the target location on the backup system

```
[Major]  
Filesystem \\.\Volume{9640da9a-6f36-11d7-bd7a-000347add7ba} could not  
be mounted to C:\mnt.  
([145] The directory is not empty.)
```

When a backup with nested mountpoint objects is run, replica cannot be mounted to the target mountpoint location on the backup system if cleaning of the target mountpoint location fails.

Action

On the backup system, manually empty the directory where filesystems are to be mounted or select the backup option **Automatically dismount the filesystems at destination mountpoints**. If you choose manual action, and leave the default root mount path `c:\mnt` in the ZDB backup specification, you should empty the `mnt` directory.

Problem

On a Windows Server 2003 system, the HPE P6000 / HPE 3PAR SMI-S Agent fails to resolve filesystem objects during the backup system preparation

[Major]

Resolving of filesystem G:\ failed. (Details unknown.)

[Minor]

Preparation of the backup system failed.

The HPE P6000 / HPE 3PAR SMI-S Agent, after presenting a replicated disk and finishing rescan, starts searching filesystem volumes attached to this disk. However, on some Windows Server 2003 systems, more time is needed to recognize filesystem volumes and make them available for mount operations. As a result of this delay, the HPE P6000 / HPE 3PAR SMI-S Agent fails to resolve filesystem objects on the backup system.

Action

Enable volume rescan retries with a defined delay period as follows:

1. On the backup system, set `ZDB_VOLUMESCAN_RETRIES` and `ZDB_POST_RESCAN_DELAY` options to moderately higher values (defaults are 5 retries and 30 seconds delay time).
2. Restart the backup session.

Problem

Data Protector fails to delete a replica from the replica set in a cluster environment

A ZDB session reports the following major error and message:

[Major]

Resolving of storage volume *TargetVolumeID* has failed.

...

[Normal]

Some disks are still in use. They will be moved in purge bucket.

This error may occur in a cluster environment with the backup system which is a cluster virtual server. In such circumstances, after a failover, new backup sessions cannot rotate out the replicas on the active node because the presentations match the passive node. The replicas to be removed are marked with the purge flag in the SMISDB, and you are advised to delete such replicas.

Action

To delete the replicas with the purge flag from the disk array and the SMISDB, perform one of the following actions:

- Manually delete all storage volumes that are marked for purging by running:

```
omnidbsmis -purge [-force] -host ClientName
```

where *hostname* is the name of the node on which you want to perform the purge operation.
Use the `-force` option to remove the volumes marked for purging even if they are presented to a system.
- Perform manual failover and run another ZDB session. The session will delete all the volumes marked for purging on the new active node.

Problem

On an HP-UX system, backup session freezes during either preparation or resuming of the backup system

One of the following messages appears:

```
[Normal]  
Starting drive discovery routine.
```

```
[Normal]  
Resuming the backup system.
```

During the backup system preparation, Data Protector adds new devices to the Secure Path control and runs device scanning. When resuming the backup system, Data Protector removes devices from the Secure Path control and runs device scanning.

If some other process runs Secure Path commands or device scanning at the same time (during either preparation or resumption), the session may freeze. To identify this problem, run the `ps -ef` command several times on the backup system and check if any `ioscan` or `spmgr` processes persist in the output.

Action

Abort the backup session and stop the hanging `ioscan` and `spmgr` processes.

If processes cannot be stopped, restart the backup system and clean it up manually:

1. On the backup system, run `spmgr display` to display the target volumes (created in the failed session) left under the Secure Path control.
2. Remove such target volumes from the Secure Path control using `spmgr delete`.
3. Run `spmgr update`, and then follow reported instructions to make changes persistent across system restart processes.
4. Using the SMI-S P6000 EVA Array provider user interface, delete all presentations attached to removed target volumes.

Problem

Data Protector zero downtime backup session fails while resolving the source volumes

On a Windows system, after a new Continuous Access (CA) link is created for a source volume, the ZBD sessions that involve this volume fail. The root cause of the problem is inability to resolve the

newly created CA link, because the SMI-S P6000 EVA Array provider cache is not up to date. You must explicitly refresh the provider cache before invoking the ZDB session.

Action

Perform any of the following steps before restarting the session:

- On the EVA command view system, run the following command:
`CLIFreshTool.bat`
The default installation directory of the command is `C:\Program Files\Hewlett-Packard\SMI-S\CXWSCimom\bin`.
- On the EVA command view system, restart the SMI-S P6000 EVA Array provider by restarting the HP StorageWorks CIM Object Manager service.
- Wait for 30 minutes to allow for the SMI-S P6000 EVA Array provider cache to get updated.

Problem

On Linux systems, a backup to LVM volumes fails.

The option **Leave the backup system enabled** was selected for the backup. The following error message is displayed:

```
[Major] From: SMISA@company.com "SMISA" Time: 12/06/2013 1:06:26 PM
```

```
It is possible that duplicated LVM UUIDs and/or names will appear on the backup system.
```

```
Session will abort.
```

Action

Set the `lvm.conf` file parameters properly. For more information, see the ["Prerequisites" on page 19](#).

Problem

A warning message is displayed in the Windows event logs when using the SMI-S P6000 EVA Array with two or more number of replicas rotated, and **Keep the replica after the backup** and **Leave backup system enabled** options selected.

Action

No action is required as this warning does not have a negative impact on the backup. The warning message appears when two or more number of replicas are rotated, and **Keep the replica after the backup** and **Leave backup system enabled** options are selected.

Instant recovery problems

Problem

Instant recovery fails

The problem may occur if the option **Force the removal of all replica presentations** is not selected and a target volume from the selected replica is presented to some system other than the backup system or the target volume cannot be dismounted.

Action

Select the option **Force the removal of all replica presentations** and restart the instant recovery session.

Problem

On a Windows system, instant recovery to a different cluster node fails

```
[Major]
Filesystem volume_name could not be dismounted from drive_letter
([2] The system cannot find the file specified.).
[Critical]
Failed to disable the application system.
[Critical]
Failed to resolve objects for Instant Recovery.
```

On Windows systems, the automatic preparation of the application system cannot match clustered volumes from one cluster node to the volumes on another node.

Action

Disable the automatic preparation of the application system:

1. On the application system, enable the ZDB_IR_MANUAL_AS_PREPARATION options (see ["Appendix" on page 228](#)) and manually dismount the volumes to be restored.
2. Start instant recovery.
3. After instant recovery, manually mount restored volumes.

Problem

On a Windows system, CA+BC instant recovery fails

```
[Major]
From: SMISA@iwf1112071.ind.hp.com "SMISA" Time: 11/6/2013 12:25:32 PM
Successfully resolved a data replication group
Storage volume : 50014380013BD520\\Virtual Disks\DPQA\iwf1112071_DR1\ACTIVE
Group name      : <DR Group name>
[Major]
From: SMISA@iwf1112071.ind.hp.com "SMISA" Time: 11/6/2013 12:25:32 PM [236:7437]
A storage volume is in a data replication group. Restore is not possible.
```

On a Windows system, after a new Continuous Access (CA) link is removed for a source volume, the ZBD sessions that involve this volume fail. The root cause of the problem is the inability to resolve that the volumes was recently removed from the DR group, because the SMI-S P6000 EVA Array provider cache is not up to date. You must explicitly refresh the provider cache before invoking the ZDB session.

Action

Perform any of the following steps before restarting the session:

- On the EVA command view system, run the following command:
`CLIRefreshTool.bat`
The default installation directory of the command is `C:\Program Files\Hewlett-Packard\SMI-S\CXWSCimom\bin`.
- On the EVA command view system, restart the SMI-S P6000 EVA Array provider by restarting the HP StorageWorks CIM Object Manager service.
- Wait for 30 minutes to allow for the SMI-S P6000 EVA Array provider cache to get updated.

Part 3: HPE P9000 XP Disk Array Family

This part describes how to configure the Data Protector HPE P9000 XP Disk Array Family integration, how to perform zero downtime backup and instant recovery using the HPE P9000 XP Disk Array Family integration, and how to resolve the integration-specific Data Protector problems.

Chapter 9: Configuration and maintenance

Introduction

This chapter describes the configuration of the Data Protector HPE P9000 XP Disk Array Family (HPE P9000 XP Disk Array Family) integration. It also provides information on the ZDB database and on how to maintain the integration.

Prerequisites

- Obtain or install:

P9000 XP Array components:

- RAID Manager Library on the application system and the backup system.

RAID Manager Library is disk array firmware-dependent. For information on which version of RAID Manager Library to use, see the latest support matrices at <https://softwaresupport.hpe.com/>. For installation instructions, see the RAID Manager Library documentation.

Note that snapshots are supported only by the disk array microcode 50-04-20 and newer versions, and only by RAID Manager Library 01.15.00 and newer versions.

To enable Data Protector to use a disk array through a command device which is operating in the user authentication mode (available only with specific disk array models), you must use a specific RAID Manager Library version. For the version number and additional information, see the latest support matrices at <https://softwaresupport.hpe.com/>.

- HPE Continuous Access (CA) P9000 XP and/or HPE Business Copy (BC) P9000 XP license and microcode.
- An appropriate multi-path device management software.

The software must be installed on the application system and the backup system.

HP-UX systems: HPE Secure Path (HP-UX)

On HP-UX 11.31 systems, the multi-path device management software is not required since the operating system has native device multi-pathing capability.

Linux systems: HPE Device Mapper Multipath Enablement Kit for HPE Disk Arrays 4.2.0 or newer version

To configure the installed multi-path device management software:

- i. Start the multipath daemon.
- ii. Execute the following command to configure the daemon so that it gets started during system startup:

Red Hat Enterprise Linux: `chkconfig multipathd on`

SUSE Linux Enterprise Server: `chkconfig boot.multipath on`

Windows systems: HPE MPIO Full Featured DSM (Device Specific Module) for HPE P9000 XP Disk Array Family

Data Protector licenses and components:

- Appropriate zero downtime backup extension and instant recovery extension licenses-to-use (LTU).
- HPE P9000 XP Agent on the application system and the backup system.

For installation and upgrade instructions and licensing information, see the *HPE Data Protector Installation Guide*.

- Make sure that the same operating system version is installed on the application system and the backup system.
- If the application system and the backup system reside in a Data Protector cell with secured clients, ensure that access between both systems is allowed in both directions.
- Make sure the SAN environment and the P9000 XP Array storage systems are properly configured:
 - Primary volumes (P-VOLs) are available to the application system.
 - Secondary volumes (S-VOLs) of the desired type (mirror, snapshot storage volume) are available to the backup system.
 - A pair relationship is defined between both sets of volumes (LDEVs) with HPE P9000 XP Remote Web Console (formerly known as HPE Command View XP).
 - LUNs are assigned to the respective ports.
- On HP-UX 11.31 systems, if you use VxVM disk groups, enable the legacy Device Special Files format.

Prerequisites for Linux systems

- For each configured S-VOL, follow the steps:
 - a. Put the corresponding LDEV pair into the SUSPENDED state, that is, suspend the pair relationships between the S-VOL and its P-VOL.
 - b. If multiple S-VOLs are in a pair relationship with its P-VOL, change the UUID of the S-VOL by executing the command `pvchange -u PVName` on the backup system, where *PVName* is the LVM physical volume name of the S-VOL.

Prerequisites for HP-UX

From Data Protector 9.05 onwards, only for SSEA backups, it is required to have LVM on HP-UX updated to the latest OS patch where "lvmadm" command is present. Hence, HP-UX must be "HP-UX 11iv3 March 2008" or newer.

Prerequisites for Windows systems

- On Windows Server 2003 and Windows Server 2008 systems, disable the operating system option **Automatic mounting of new volumes**. In the Command Prompt window, execute the command `mountvol /N`.
- Do not manually mount target volumes that were created by Data Protector.

For additional prerequisites for using HPE P9000 XP Disk Array Family with the Data Protector Microsoft Volume Shadow Copy Service integration, see the *HPE Data Protector Integration Guide for Microsoft Volume Shadow Copy Service*.

Limitations

- In cluster environments, the backup system must not be in the same cluster with the application system. Additionally, the backup system cannot be the cluster virtual server, it can only be a cluster node.
- Zero downtime backup using snapshots is only supported in HPE Business Copy (BC) P9000 XP and HPE Continuous Access + Business Copy (CA+BC) P9000 XP configurations.
- Instant recovery is only supported in HPE Business Copy (BC) P9000 XP configurations.
- Using split mirror restore, you can only restore filesystems and disk images backed up in HPE Business Copy (BC) P9000 XP configurations, including their single-host (BC1) implementations. Other Data Protector backup object types are not supported.

For information on any of the following items, see the HPE Data Protector Product Announcements, Software Notes, and References:

- General Data Protector and integration-specific limitations
- Supported platforms and integrations
- Supported backup and connectivity topologies

For information on supported configurations, see the *HPE Data Protector Concepts Guide*.

ZDB database – XPDB

ZDB database for the Data Protector HPE P9000 XP Disk Array Family integration is referred to as **XPDB**. It keeps information about:

- LDEV pairs that are split (put into the SUSPENDED state). This information includes:
 - ID of the ZDB session that involved handling the LDEV pair.
 - LDEV, volume group, and filesystem configuration.
 - CRC information calculated during the session.
 - IR flag (indicating that the target volume can be used for instant recovery)
- Filesystem and volume management system information.

The information is written to the XPDB when a LDEV pair is put into the SUSPENDED state, and is deleted from the XPDB when a LDEV pair is resynchronized (is put into the PAIR state). During resynchronization, prior version of data is overwritten.

Volume group configuration and the CRC information stored in XPDB is compared to the volume group configuration and the CRC information obtained during an instant recovery session. If these items do not match, the session fails.

Objects and their configuration during backup and restore sessions are kept in the XPDB for replica set rotation and instant recovery. Only the LDEV pairs tracked in the XPDB can be used for instant recovery.

XPDB resides on the Cell Manager in:

Windows systems: `Data_Protector_program_data\server\db80\xpdb`

UNIX systems: `/var/opt/omni/server/db80/xpdb`

Configuring the integration

Before you start with the configuration, make sure the prerequisites listed in ["Introduction" on page 78](#) are fulfilled. In addition, do the following:

Solaris systems: Run the Sun format utility to label and format the paired LDEVs (on both the application system and the backup systems). For information, see the *HPE Disk Array XP Operating System Configuration Guide: Sun Solaris*.

HPE BC P9000 XP configurations: Connect the application system and the backup system to the same disk array unit.

When using first-level mirrors or snapshot volumes, primary LDEVs (P-VOLs) must be connected to the application system and the paired secondary LDEVs (S-VOLs) must be connected to the backup system.

HPE CA P9000 XP configurations: Connect the application system to the Main Control Unit (MCU), and the backup system to the Remote Control Unit (RCU). ESCON links provide communication links between the P9000 XP Array MCU and RCU.

Main LDEVs (P-VOLs) must be connected to the application system and have paired disks (S-VOLs) assigned. Paired LDEVs (S-VOLs) in the remote disk array must be connected to the backup system.

Combined (HPE CA+BC P9000 XP) configurations: Connect the application system to the MCU, and the backup system to the RCU.

Main LDEVs (P-VOLs) must be paired to remote volumes in the RCU (S-VOLs). S-VOLs also function as HPE BC P9000 XP primary volumes (P-VOLs) and must be paired to local copies (HPE BC P9000 XP S-VOLs):

- **Windows systems:** Connect only HPE BC P9000 XP S-VOLs to the backup system.
- **HP-UX systems:** Connect only HPE BC P9000 XP S-VOLs to the backup system. If HPE CA P9000 XPS-VOLs are connected as well, special care must be taken if `/etc/lvmtab` is lost in this configuration: use `vgscan` to recreate the volume groups and `vgreduce` to delete potentially added `pvlinks` to the S-VOLs. Re-import or re-create the volume groups to ensure the configuration is correct.
- **Linux systems:** Connect only HPE BC P9000 XP S-VOLs to the backup system.

HP-UX LVM mirroring: Use the physical volume groups mirroring of LDEVs to ensure that each logical volume is mirrored to an LDEV on a different I/O bus. This arrangement is called **PVG-strict mirroring**. Disk hardware must be already configured, so that each secondary LDEV is connected to the system on a different bus (not the bus used for the primary LDEV).

1. Create the volume group with the LDEVs that have S-VOLs assigned using `vgcreate`. LVM mirror primary volumes must be the LDEVs that have their S-VOLs.

2. Extend the volume group with LDEVs that have no S-VOLs assigned using `vgextend`. LVM mirror secondary volumes must be the LDEVs that have no S-VOLs.

Note: When using LVM mirroring with the SSEA integration, the devices in the logical volume can also be non-XP devices, such as IBM or EVA.

For more information on LVM mirroring, see the document *Managing Systems and Workgroups: A Guide for HP-UX System Administrators*.

To configure the integration:

- Set the P9000 XP Array command devices. See ["Command device handling" below](#).
- If needed, set the P9000 XP LDEV exclude file. See ["P9000 XP LDEV exclude file" on page 84](#).
- To enable zero downtime backup and instant recovery sessions that involve a disk array which is operating in the user authentication mode, configure the user authentication data. See ["Configuring the user authentication data" on the next page](#).

Command device handling

HPE P9000 XP Disk Array Family **command devices** are dedicated volumes in the disk arrays which act as the interface between management applications and the storage systems. They cannot be used for data storage and only accept requests for operations that are then executed by the disk arrays. A command device is needed and used by any process requiring access to a P9000 XP Array. Data about all command devices detected by Data Protector is stored in the XPDB for the purpose of avoiding concurrent overallocation of each particular command device.

Whenever a ZDB session is started, the Data Protector HPE P9000 XP Agent queries the XPDB for a list of command devices, and updates it if needed. When the first ZDB session is started, the HPE P9000 XP Agent generates a list of command devices connected to every application and backup system in the cell. All subsequent sessions automatically update the list if the configuration of command devices has changed.

Every command device is assigned an instance number (starting from 301) and the system name (hostname) having access to it. If a command device can be accessed from more than one system, the HPE P9000 XP Agent recognizes that the command device is assigned to another system; such a command device-hostname combination gets the next available instance number.

Thus, every P9000 XP Array storage system attached to the application and backup systems has a list of command devices and systems having access to them (together with an instance number).

Below is an example of command device entries in the XPDB:

```
Serial#CU:Ldev(LDEV)InstSystem
=====
3537100:67(103)301application.system1.com
3537100:67(103)302backup.system.com
3537200:68(104)301application.system2.com
3537300:69(105)301application.system3.com
```

To be able to control which command device and instance number should be used on a specific system, you can disable the automatic update of the command device list in the XPDB. To disable the automatic update:

1. Set the `SSEA_QUERY_STORED_CMDDEVS omnirc` option to 1.
2. Use the `omnidbxp` command to manually add, list, remove, and update the command devices.

For the command syntax and examples, see the *HPE Data Protector Command Line Interface Reference* or the `omnidbxp` man page

If you decide to disable the automatic update, the initial list of command devices is still created in the XPDB during the first ZDB session. For subsequent backup sessions, the Data Protector HPE P9000 XP Agent behavior is as follows:

- Whenever an application system or a backup system needs access to the P9000 XP Array storage system during a session, it uses the first assigned command device with the instance number from the list.
- If the command device fails, the next device from the list is used.
- If all devices fail, the session fails.
- If successful, the command device is used by the system until the end of the session, and the list of command devices is used for all consecutive sessions.

Configuring the user authentication data

Specific disk array models of the HPE P9000 XP Disk Array Family provide increased security with authorization verification that involves user and resource groups, roles, and user authenticity verification. Authorization verification is enabled by a special operating mode called **user authentication mode**. When an application, for example the Data Protector HPE P9000 XP Agent, communicates with a disk array which is operating in this mode, the application must supply appropriate user credentials in order for queries and modifications of the disk array configuration or its resources to succeed. On the disk arrays on which the conventional operating mode is still available for compatibility reasons, the user authentication mode is disabled by default.

Authorization system of a disk array on which the user authentication mode is available defines a fixed set of roles that belong to different task groups: security-related, storage-related, and maintenance-related tasks. It assigns a particular subset of roles and a particular set of resource groups to each user group. While there are several preconfigured user groups, which can be used immediately, you can easily create additional ones. Each disk array user account can belong to multiple user groups. Similarly, each user group can have multiple resource groups assigned, and each resource group can belong to multiple user groups. Each time an application attempts to start a specific operation on a specific resource of the disk array, the authorization system first determines the user account based on the supplied user credentials. It then checks if any user group the user account belongs to is allowed to perform the operation on the resource. If user credentials are not supplied, the disk array always rejects to execute the operation.

The operating mode setting is actually a command device property. For example, if a particular backward compatible disk array has two command devices configured, one can operate in the conventional mode and the other in the user authentication mode. It therefore depends on the configuration of the command device used whether the application should supply user credentials to successfully start the requested operation.

For more information on using the HPE P9000 XP Disk Array Family authorization system, see the *HPE P9000 Remote Web Console User Guide* and other parts of the HPE P9000 XP Disk Array Family documentation set.

User authentication data and the XPDB

To enable the HPE P9000 XP Agent to perform zero downtime backup (ZDB) and instant recovery (IR) sessions using a command device for which the user authentication mode is enabled, you must add appropriate user credentials to the ZDB database (XPDB) in advance. The credentials must belong to a disk array user account which has the *Local Copy*, the *Remote Copy*, or both roles assigned, depending on the HPE P9000 XP Disk Array Family configuration. The HPE P9000 XP Agent then reads the credentials from the XPDB each time such a ZDB or IR session is started. User credentials are bound to a specific disk array serial number. For each particular serial number, you can add user credentials of a single disk array user account. To add and manage user credentials in the XPDB, use the Data Protector `omnidbxbp` command.

Configuration procedure

To properly add the required user credentials for a specific disk array that will be involved in the ZDB and IR sessions, follow the steps:

1. Identify the serial number of the disk array.
2. Identify which disk array volumes (LDEVs) will be involved in the ZDB and IR sessions.
3. Identify which disk array user group has been granted adequate access to all volumes that you identified in the previous step
4. Choose a disk array user account that belongs to the disk array user group from the previous step. Identify and write down its user name and password that you will need in the next step.
5. Using the `omnidbxbp -user -add` command, add the user name and password that you acquired in the previous step to the XPDB, providing the disk array serial number you identified in step 1 of this procedure.

For command syntax and usage examples, see the `omnidbxbp` reference page in the *HPE Data Protector Command Line Interface Reference* or the `omnidbxbp man` page.

6. Using the `omnidbxbp -user -check` command, verify that the HPE P9000 XP Agent can connect to the disk array using the configured user authentication data.

For more information on performing other tasks related to management of user credentials in the XPDB, see the `omnidbxbp` reference page in the *HPE Data Protector Command Line Interface Reference* or the `omnidbxbp man` page.

P9000 XP LDEV exclude file

You can reserve certain LDEVs for purposes other than Data Protector backup and restore. A session is aborted if the participating replica contains an excluded LDEV.

Disabled secondary LDEVs (S-VOLs) are listed in the P9000 XPLDEV exclude file on the Cell Manager:

Windows systems: `Data_Protector_program_data\server\db80\xpdb\exclude\XPexclude`

UNIX systems: `/var/opt/omni/server/db80/xpdb/exclude/XPexclude`

Secondary LDEVs (S-VOLs) listed in this file must be the backup system LDEVs identified by the backup system LDEV#.

Use the `omnidbxbp` command to:

- set and change the exclude file
- identify excluded LDEVs
- reset the exclude file
- delete the content of the exclude file

For the command syntax and the examples of manipulating the exclude file, see the *HPE Data Protector Command Line Interface Reference* or the `omnidbxdp` man page. The file syntax and the example are as follows.

Syntax

```
#
#       HPE Data Protector A.09.00
#       HPE P9000 XP Disk Array Family LDEV Exclude File
#
#       [<XP1>]
#       <LDEV>
#       <LDEV1>, <LDEV2>, <LDEV3>
#       <LDEV1>-<LDEV2>

#       [<XP2>]
#       ...
#
#       <XP>   - disk array serial/sequence number
#       <LDEV> - CU#:LDEV number in decimal format
#
#       End of file
```

Example

```
#
#       HPE Data ProtectorA.09.00
#       HPE P9000 XP Disk Array Family LDEV Exclude File
#
#       [35241]
#       3603, 3610, 3620-3625 # Some excluded LDEVs
#       2577 #
#       2864-3527 #
#
#       End of file
```

Automatic configuration of the backup system

When you start a ZDB session, Data Protector performs necessary configuration steps, such as configuring volume groups and filesystems on the backup system. Based on the volume group, filesystem, and mount point configuration on the application system, Data Protector creates the same volume group and filesystem structure on the backup system and mounts these filesystems during a ZDB-to-tape or ZDB-to-disk+tape session.

For more information on the backup system mountpoint creation, see ["Appendix" on page 228](#).

Maintaining the integration

Maintenance tasks include querying the information kept in XPDB, in particular:

- available zero downtime backup sessions
- backup system LDEVs involved in a particular session
- backup system LDEVs stored in the XPDB
- XPDB information about particular LDEV pairs

You can retrieve the information stored in the XPDB using the `omnidbxp` command. For the command syntax and usage examples, see the *HPE Data Protector Command Line Interface Reference* or the `omnidbxp` man page.

Chapter 10: Backup

Introduction

This chapter describes configuring filesystem and disk image ZDB using the Data Protector GUI.

You should be familiar with the HPE P9000 XP Disk Array Family concepts and procedures and basic Data Protector ZDB and instant recovery functionality. See the HPE P9000 XP Disk Array Family documentation and the *HPE Data Protector Concepts Guide*.

ZDB types

Using the P9000 XP Array integration, you can perform:

- **ZDB to disk**

The replica produced is kept on a disk array until reused. This replica becomes part of the replica set and can be used for instant recovery.

ZDB to disk is performed if the option **Track the replica for instant recovery** is selected in a ZDB backup specification, and **To disk** is selected when running/scheduling a backup.

ZDB to disk is only possible using the HPEBC P9000 XP configuration.

- **ZDB to tape**

The replica produced is streamed to backup media, typically tape, according to the tape backup type you have selected (Full, Incr, Incr1-9).

This replica is deleted after backup if the option **Keep the replica after the backup** is *not* selected in a ZDB backup specification. If this option is selected, the replica remains on a disk array until reused and becomes part of the replica set. However, it cannot be used for instant recovery.

- **ZDB to disk+tape**

The replica produced is kept on a disk array until reused and is also streamed to backup media according to the tape backup type you have selected (Full, Incr, Incr1-9). This replica becomes part of the replica set and can be used for instant recovery.

ZDB to disk+tape is performed when the option **Track the replica for instant recovery** is selected in a ZDB backup specification, and **To disk+tape** is selected when running/scheduling a backup.

ZDB to disk+tape is only possible using the HPE BC P9000 XP configuration.

Replica types

Using the P9000 XP Array integration, you can create the following replica types:

- split mirror

This replica type is supported by all disk array models of the HPE P9000 XP Disk Array Family that are officially supported by Data Protector.

- snapshot

This replica type is supported by specific P9000 XP disk array microcode versions and specific RAID Manager Library versions only. For details, see the prerequisite list in ["Introduction" on page 78](#).

You cannot directly select a replica type when configuring a Data Protector ZDB backup specification. You must choose the replica type in advance when creating secondary LDEVs (S-VOLs) with HPE P9000 XP Remote Web Console (formerly known as HPE Command View XP). During ZDB sessions, the Data Protector HPE P9000 XP Agent always uses the S-VOLs (the target volumes specified in the ZDB backup specification) in the same way, regardless of their type – mirror or snapshot storage volume. Thus, you can even create replica sets of which specific replicas are mirror copies and others are snapshots.

In general, both replica types are available for all ZDB types, for instant recovery, and for split mirror restore. However, a specific limitation applies to the HPE Continuous Access (CA) P9000 XP configurations. See the limitation list in ["Introduction" on page 78](#).

Backup concepts

P9000 XP Array zero downtime backup consists of two phases:

1. The data from P-VOLs presented to the application system is synchronized with the S-VOLs presented to the backup system.

During this phase, the synchronization is performed on the level of participating volume groups (UNIX systems) or disks (Windows systems). Therefore, if multiple filesystems/disk images are configured in the same volume group or on the same disk, the *entire* volume group or disk (all filesystems or disk images in the group or on the disk) is synchronized to the backup system regardless of the objects selected for backup.

2. Synchronized backup system data is backed up to a backup device.

During this phase, only the objects selected for backup are backed up.

Note: With ZDB to disk, the second phase does not occur. Backed up data can only be restored using instant recovery.

This concept enables a restore of selected objects for a split mirror restore and restore from backup media on LAN, but not for instant recovery.

With instant recovery, the links from the application to backup system are *not* synchronized before the restore, whereas with a split mirror restore they *are*, thus enabling the restore of selected objects by establishing the current state of the application system data on the backup system, and then restoring selected objects to the backup system and resynchronizing the backup system to the application system.

Creating backup specifications

Considerations

- Consider all limitations that apply to the Data Protector P9000 XP Array integration. See the HPE Data Protector Product Announcements, Software Notes, and References, the *HPE Data Protector Concepts Guide*, and the limitation list in ["Introduction" on page 78](#).

Procedure

To create a ZDB backup specification for a disk array of the HPE P9000 XP Disk Array Family using the Data Protector GUI (**Data Protector Manager**), follow the steps:

1. In the Context List, select **Backup**.
2. In the Scoping Pane, expand **Backup Specifications**. Right-click **Filesystem** (for both object types: filesystem and disk image) and click **Add Backup**.

The Create New Backup dialog box appears.

In the Filesystem pane, select the **Blank Filesystem Backup** template or some other template which you might have created. For information on templates, see the *HPE Data Protector Help* index: "backup templates".

Select **Snapshot or split mirror backup** as **Backup type** and **HPE P9000 XP** as **Sub type**. For descriptions of options, press **F1**.

Click **OK**.

3. Under Client systems, select **Application system** and **Backup system**. If the application system is part of a server cluster, select the virtual server.
4. Under Mirror type, select the P9000 XP Array configuration, and specify a value for **MU number (s)**. The maximum number of replicas that can be created for the same source volumes is different for mirror copies and snapshots. Both limitations are imposed by the P9000 XP Array storage system.

P9000 XP Array backup options

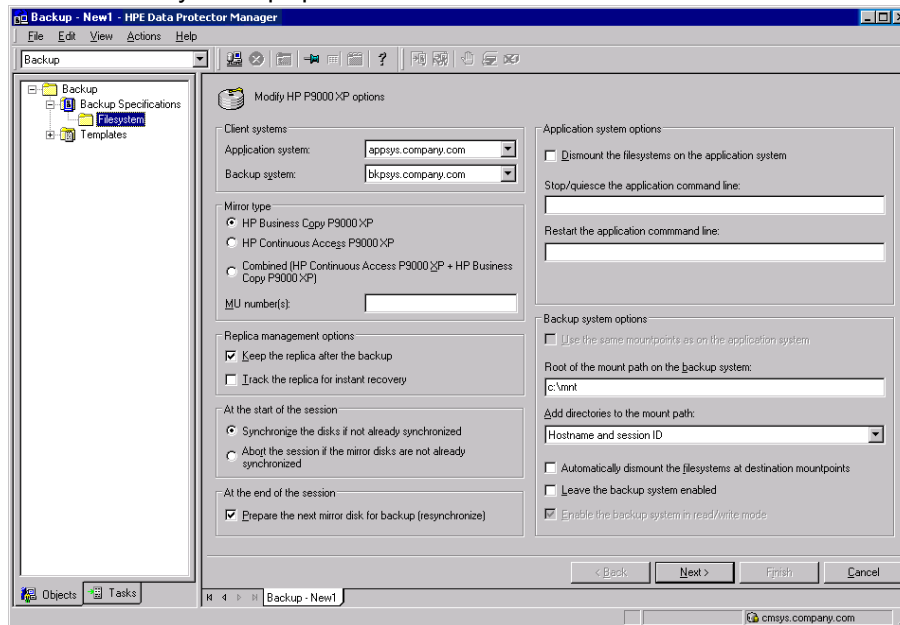

5. Under Replica management options, select the desired options.

ZDB to disk, ZDB to disk+tape:

Select the option **Track the replica for instant recovery** to enable instant recovery.

Note: You can choose a ZDB-to-disk session or a ZDB-to-disk+tape session by selecting an

appropriate value for the **Split mirror/snapshot backup** option when running or scheduling a ZDB session based on this ZDB backup specification. See "[Scheduling ZDB sessions](#)" on [page 228](#).

ZDB to tape:

Leave the option **Track the replica for instant recovery** cleared.

To preserve the replica on the disk array after the ZDB session, leave the option **Keep the replica after the backup** selected. To remove the replica after the session, clear this option.

6. Under At the start of the session and At the end of the session, specify how states of the source volumes and the corresponding target volumes are handled during zero downtime backup sessions.
7. Specify other zero downtime backup options as desired. For information, see "[Backup options](#)" on [page 92](#) or press **F1**.
8. Select the desired backup objects.

Filesystem backup: Expand the application system and select the objects to be backed up. Note that all drive letters or mount points that reside on the system are displayed. You must select only the objects that reside on the disk array, otherwise the ZDB session will fail.

To ensure that instant recovery succeeds and the environment is consistent after instant recovery, select all volumes on a disk (Windows systems) or all logical volumes of a volume group (UNIX systems) to be backed up. Even if you do not select an entire disk or volume group, the backup will succeed, but instant recovery may experience issues during configuration check of the environment. The configuration check can be disabled by clearing the option **Check the data configuration consistency** in the GUI or not specifying the option `-check_config` in the CLI when preparing for an instant recovery session. If this option is cleared (GUI) or not specified (CLI), the entire disk or volume group will be overwritten during instant recovery.

Click **Next**.

Disk image backup: Click **Next**.

9. Select devices. Click **Properties** to set device concurrency, media pool, and preallocation policy. For information on these options, click **Help**.

To create additional copies (mirrors) of backup, specify the desired number of mirrors by clicking **Add mirror** or **Remove mirror**. Select separate devices for the backup image and each mirror. For information on object mirroring, see the *HPE Data Protector Help* index: "object mirroring".

Note: Object mirroring and object copying are not supported for ZDB to disk.

Click **Next**.

10. In the Backup Specification Options group box, click **Advanced** and then the **HPE P9000 XP** tab to open the P9000 XP Array backup options pane.

You can specify Application system options and modify all other options, except **Application system** and **Backup system** (note that you can change them after you save the ZDB backup specification). See "[Backup options](#)" on [page 92](#) or press **F1**.

In the Filesystem Options group box, click **Advanced** and specify filesystem options as desired. For information, press **F1**.

Windows systems: To configure a ZDB backup specification for incremental ZDB sessions, select the **Do not use archive attribute** filesystem option in the WinFS Options pane to enhance the incremental ZDB behavior. For details, see "[Backup options](#)" on the next page

Click **Next**.

11. Following the wizard, open the scheduler to schedule the ZDB sessions. For more information, see "[Scheduling ZDB sessions](#)" on page 228 or press **F1**.

Click **Next**.

12. In the Backup Object Summary page, specify additional options.

Filesystem backup: You can modify options for the listed objects by right-clicking an object and then clicking **Properties**. For information on the object properties, press **F1**.

Disk image backup: Follow the steps:

- a. Click **Manual add** to add disk image objects.
- b. Select **Disk image object** and click **Next**.
- c. Select the client system. Optionally, enter the description for your object. Click **Next**.
- d. Specify General Object Options and Advanced Object Options. For information on these options, press **F1**.
- e. In the Disk Image Object Options window, specify disk image sections.

Windows systems:

Use the format

`\\.\PHYSICALDRIVE#`

where # is the current number of the disk to be backed up.

For information on how to identify current disk numbers (physical drive numbers), see the *HPE Data Protector Help* index: "disk image backups".

HP-UX and Solaris systems:

Specify a disk image section:

`/dev/rdisk/filename`, for example: `/dev/rdisk/c2t0d0`

On HP-UX 11.31 systems, the new naming system can be used:

`/dev/rdisk/disk#`, for example `/dev/rdisk/disk2`

Specify a raw logical volume section:

`/dev/vgnumber/r1volNumber`, for example: `/dev/vg01/r1vol1`

Linux systems:

Specify a disk image section:

`/dev/Filename`, for example: `/dev/dm-10`

To ensure that instant recovery succeeds and the environment is consistent after instant recovery, select all volumes on a disk (Windows systems) or all logical volumes of a volume group (UNIX systems) to be backed up. Even if you do not select an entire disk or volume group, the backup will succeed, but instant recovery may experience issues during configuration check of the environment. The configuration check can be disabled by clearing the option **Check the data configuration consistency** in the GUI or not specifying the option `-check_config` in the CLI when preparing for an instant recovery session. If this option is cleared (GUI) or not specified (CLI), the entire disk or volume group will be overwritten during

- instant recovery.
- f. Click **Finish**.
- Click **Next**.
- 13. Save your ZDB backup specification.

For information on scheduling ZDB sessions and starting interactive ZDB sessions, see "[Scheduling ZDB sessions](#)" on page 228.

Note: Backup preview is not supported.

Backup options

The following tables describe the P9000 XP Array and ZDB related backup options. See also "[P9000 XP Array integration](#)" on page 259.

Client systems

Application system	The system on which the application runs. In cluster environments, specify the virtual server hostname (rather than the physical node hostname).
Backup system	The system to which your data will be replicated (backed up). In ZDB-to-disk+tape and ZDB-to-tape sessions, the backup data is copied from this system to a backup device.

Mirror type

HPE Business Copy P9000 XP	Select this option to configure a ZDB backup specification for the HPE P9000 XP Disk Array Family configuration HPE Business Copy P9000 XP. Default: selected.
HPE Continuous Access P9000 XP	Select this option to configure a ZDB backup specification for the HPE P9000 XP Disk Array Family configuration HPE Continuous Access P9000 XP. Default: not selected.
Combined (HPE Continuous Access P9000 XP + HPE Business Copy P9000 XP)	Select this option to configure a ZDB backup specification for the HPE P9000 XP Disk Array Family combined configuration HPE Continuous Access P9000 XP + HPE Business Copy P9000 XP. Default: not selected.
MU number(s)	This option is only available if the HPE P9000 XP Disk Array Family configuration HPE Business Copy P9000 XP is selected.

	<p>This option defines the mirror unit (MU) number(s) of a replica or a replica set from which the Data Protector HPE P9000 XP Agent, according to the replica set rotation, selects the replica to be used in the zero downtime backup session. The replica selection rule is described in the <i>HPE Data Protector Concepts Guide</i>. The maximum number of replicas that can be created for the same source volumes is different for mirror copies and snapshots. Both limitations are imposed by the HPE P9000 XP Disk Array Family storage system.</p> <p>You can specify one or more non-negative integer numbers, one or more ascending ranges of such numbers, or any combination of both. Use a comma as the separator character. Examples:</p> <p>5</p> <p>7-9</p> <p>4,0,2-3</p> <p>When a sequence is specified, it does not define the order in which the replicas are used.</p> <p>Default: 0 (nothing is specified).</p>
--	---

Replica management options

<p>Keep the replica after the backup</p>	<p>If configuring a ZDB to tape, select this option to keep the replica on the disk array after the zero downtime backup session. The replica becomes part of a replica set (specify a value for the option MU number(s)). Unless the additional option Track the replica for instant recovery is selected, the replica is <i>not</i> available for instant recovery.</p> <p>If this option is not selected, the replica is removed at the end of the session.</p> <p>If the option Track the replica for instant recovery is selected, this option is automatically selected and cannot be changed.</p> <p>Default: selected.</p>
<p>Track the replica for instant recovery</p>	<p>This option is only available if the HPE P9000 XP Disk Array Family configuration HPE Business Copy P9000 XP is selected.</p> <p>Select this option to perform a ZDB-to-disk or ZDB-to-disk+tape session and leave the replica on the disk array to enable instant recovery.</p> <p>If this option is not selected, you cannot perform instant recovery using the replica created or reused in this session.</p>

	<p>Caution: If you select this option, do not manually resynchronize the affected mirrors and do not empty the volumes used for snapshot storage. Otherwise, instant recovery will not be possible.</p> <p>Default: not selected.</p>
--	--

At the start of the session

<p>Synchronize the disks if not already synchronized</p>	<p>On the P9000 XP Array, primary volumes (source volumes) and their corresponding secondary volumes (target volumes) must be in the PAIR state to enable Data Protector zero downtime backup: mirrors must be synchronized and volumes to be used for snapshot storage must be empty.</p> <p>This option is automatically selected and cannot be changed if the option Prepare the next mirror disk for backup (resynchronize) is cleared.</p> <p>If this option is selected, all volumes of the replica to be used in the current ZDB session are put into the PAIR state with the corresponding source volumes at the start of the session: mirrors are resynchronized and volumes to be used for snapshot storage are made empty.</p> <p>Default: selected.</p>
<p>Abort the session if the mirror disks are not already synchronized</p>	<p>Available only if the option Prepare the next mirror disk for backup (resynchronize) is selected.</p> <p>The option is only applicable if at least one volume of the replica to be used in the current ZDB session is a mirror (or mirror copy). In the opposite case, Data Protector treats as if the option Synchronize the disks if not already synchronized is selected instead.</p> <p>If this option is selected and at least one volume of the replica to be used in the current ZDB session is not in the PAIR state with the corresponding source volume, the session fails.</p> <p>Default: not selected.</p>

At the end of the session

<p>Prepare the next mirror disk for backup (resynchronize)</p>	<p>This option is only applicable if at least one volume of the replica to be used in the next ZDB session is a mirror (or mirror copy). In the opposite case, Data Protector behaves as if the option is not selected.</p> <p>If this option is selected, all volumes of the replica to be used in the next ZDB session are put into the PAIR state with the</p>
---	---

	<p>corresponding source volumes at the end of the current ZDB session: mirrors are resynchronized and volumes to be used for snapshot storage are made empty.</p> <p>If this option is not selected, the volumes of the replica to be used in the next ZDB session are left intact at the end of the current ZDB session.</p> <p>If this option is not selected, the Synchronize the disks if not already synchronized option is automatically selected, and the Abort the session if the mirror disks are not already synchronized option is not available.</p> <p>Default: selected.</p>
--	--

Application system options

<p>Dismount the filesystems on the application system</p>	<p>Select this option to dismount the filesystems on the application system before replica creation and remount them afterwards. Additionally, when entire physical drives (on Windows systems) or entire disks or logical volumes (on UNIX systems) are selected as backup objects in a disk image backup specification, selecting this option will dismount and later remount all filesystems on these objects. If any of these filesystems cannot be dismounted, the backup session fails.</p> <p>If an integrated application (for example, Oracle Server) exclusively controls the data I/O on each physical drive, disk, or logical volume that will be backed up, the dismount operation is not needed. In such a case, you can leave this option cleared.</p> <p>Default: not selected.</p>
<p>Stop/quiesce the application command line</p>	<p>If a command is specified in this option, it is invoked on the application system immediately before replica creation. An example is to stop applications not integrated with Data Protector.</p> <p>The command must reside on the application system in the default Data Protector administrative commands directory. Do not specify the path to the command in this option.</p> <p>If the command fails, the command specified in the option Restart the application command line is not invoked. Thus, you may need to implement a cleanup procedure in the command specified in Stop/quiesce the application command line. If the <code>omnirc</code> option <code>ZDB_ALWAYS_POST_SCRIPT</code> is set to 1, the command specified in the option Restart the application command line is always invoked.</p>
<p>Restart the application</p>	<p>If a command is specified in this option, it is invoked on the</p>

<p>command line</p>	<p>application system immediately after replica creation. An example is to resume operation of applications not integrated with Data Protector.</p> <p>The command must reside on the application system in the default Data Protector administrative commands directory. Do not specify the path to the command in this option.</p>
----------------------------	--

Backup system options

<p>Use the same mountpoints as on the application system</p>	<p>This option is not available if the application system is also the backup system (a single-host configuration).</p> <p>If this option is selected, the paths to mount points used for mounting the filesystems of the replica on the backup system are the same as paths to mount points where source volume filesystems were mounted on the application system.</p> <p>If the mount points are already in use, the session fails. For such circumstances, you must select the option Automatically dismount the filesystems at destination mountpoints in order for the session to succeed.</p> <p>Windows systems: The drive letters must be available, otherwise the session fails.</p> <p>Default: not selected.</p>
<p>Root of the mount path on the backup system</p>	<p>This option is only available if the option Use the same mountpoints as on the application system is not selected.</p> <p>Specifies the root directory under which the filesystems of the replica are mounted.</p> <p>Where exactly the filesystems are mounted depends on how you define the option Add directories to the mount path.</p> <div style="background-color: #f0f0f0; padding: 5px;"> <p>Note: For the SAP R/3 integration, the option is not applicable (the mount points created are always the same as on the application system).</p> </div> <p>Defaults:</p> <p>Windows systems: c:\mnt</p> <p>UNIX systems: /mnt</p>
<p>Add directories to the mount path</p>	<p>This option is only available if the option Use the same mountpoints as on the application system is not selected.</p> <p>This option enables control over the created mount points. It defines which subdirectories will be created in the directory defined with the Root of the mount path on the backup system option. When Session ID is used in path composition,</p>

	<p>this guarantees unique mount points.</p> <p>Example for Windows systems:</p> <p>Root directory: C:\mnt</p> <p>Application system: applsys.company.com</p> <p>Backup session ID: 2008-02-22-4</p> <p>Mount path on the application system: E:\disk1</p> <p>If Hostname is selected:</p> <p>C:\mnt\applsys.company.com\E\disk1</p> <p>If Hostname and session ID is selected:</p> <p>C:\mnt\applsys.company.com\2008-02-22-4\E\disk1</p> <p>If Session ID is selected:</p> <p>C:\mnt\2008-02-22-4\E\disk1</p> <p>If Session ID and hostname is selected:</p> <p>C:\mnt\2008-02-22-4\applsys.company.com\E\disk1</p> <div style="background-color: #e0e0e0; padding: 5px; margin: 10px 0;"> <p>Note: For the SAP R/3 integration, the option is not applicable (the mount points created are always the same as on the application system).</p> </div> <p>Default: Hostname and session ID.</p>
<p>Automatically dismount the filesystems at destination mountpoints</p>	<p>If the mount points are in use (for example, volumes involved in the previous session may still be mounted) and this option is selected, Data Protector attempts to dismount the mounted filesystems.</p> <p>If the option is not selected and the mount points are in use, or if the option is selected and the dismount operation fails, the session fails.</p> <p>Default: not selected.</p>
<p>Leave the backup system enabled</p>	<p>This option is only available if the option Keep the replica after the backup is selected.</p> <p>If this option is selected, the filesystems remain mounted, the volume groups remain imported and active (UNIX systems), and the target volumes remain presented after the session. In this case, you can use the backup system for data warehousing purposes, but <i>not</i> for instant recovery. If the replica has to be reused later on (deleted, rotated out, or used for instant recovery), Data Protector automatically connects to the backup system, dismounts the filesystems, unrepresents the target volumes, and clears the related logical structures on the backup</p>

	<p>system. At that point in time, if the filesystems are not mounted to the current backup system, Data Protector cannot perform a proper cleanup, and aborts the operation or the instant recovery session.</p> <p>If this option is not selected, Data Protector dismounts filesystems, exports volume groups (UNIX systems), and unrepresents the target volumes on the backup system at the end of the ZDB session.</p> <p>Default: not selected.</p>
<p>Enable the backup system in read/write mode</p>	<p>This option is applicable to and can only be changed for UNIX systems only. On Windows systems, filesystems cannot be mounted in the read-only mode.</p> <p>Select this option to enable write access to volume groups and filesystems on the backup system. For backup purposes, it is sufficient to activate the backup system volume groups and mount the filesystems in the read-only mode. For other tasks, the read/write mode may be needed.</p> <p>Note that when this option is selected, the replica is open to modifications while the backup system is online. Consequently, data restored from such a replica includes all potential modifications.</p> <p>Defaults:</p> <p>Windows systems: selected.</p> <p>UNIX systems: not selected.</p>

Note: In a particular ZDB session, the mount point paths to which filesystems of the replica are mounted on the backup system correspond the mount point paths to which source volumes were mounted on the application system if at least one of the following conditions is met:

- The GUI option **Use the same mountpoints as on the application system** is selected.
- The `omnirc` option `ZDB_PRESERVE_MOUNTPOINTS` is set to 1.

If the option **Use the same mountpoints as on the application system** is not selected, and the `omnirc` option `ZDB_PRESERVE_MOUNTPOINTS` is set to 0, the mount point paths are determined by the GUI options **Root of the mount path on the backup system** and **Add directories to the mount path**, and the `omnirc` options `ZDB_MULTI_MOUNT` and `ZDB_MOUNT_PATH` are ignored.

The chart and table below provide detailed backup flow according to the backup options selected.

ZDB session flow for filesystem backup objects

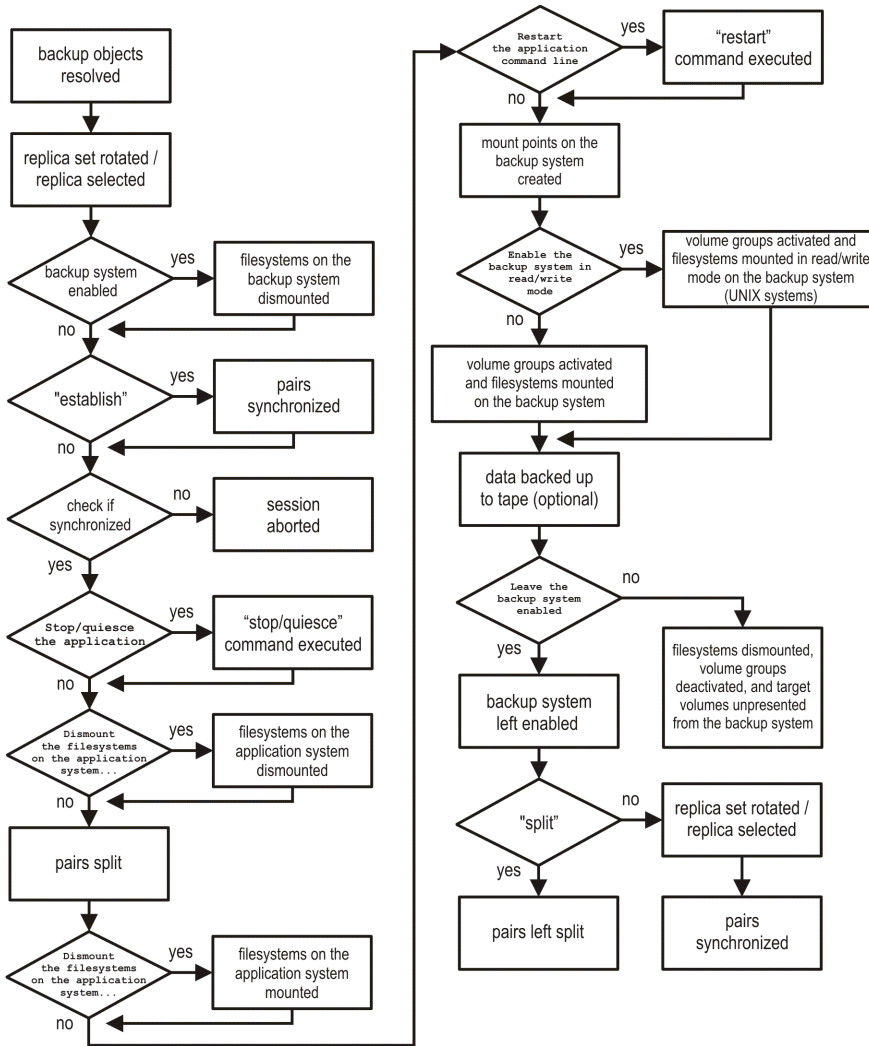

The “establish” and “split” checks depend on the P9000 XP Array zero downtime backup options listed in the table "Relation between particular zero downtime backup options and the “establish” and “split” checks " below.

Relation between particular zero downtime backup options and the “establish” and “split” checks

The option Synchronize the disks if not already synchronized is selected.	"establish" = yes
The option Abort the session if the mirror disks are not already synchronized is selected.	"establish" = no
The option Prepare the next mirror disk for backup (resynchronize) is selected.	"split" = no
The option Prepare the next mirror disk for backup (resynchronize) is cleared.	"split" = yes

No value or a single number is specified for the option **MU number(s)** or the option **Keep the replica after the backup** is selected.

"split" = yes

Chapter 11: Restore

Introduction

This chapter describes configuring and running a filesystem or disk image restore of the data backed up using the P9000 XP Array integration. The sections describe restore procedures using the Data Protector GUI and CLI.

The data backed up in a ZDB session can be stored on a disk array (ZDB to disk, ZDB to disk+tape) or on backup media (ZDB to tape, ZDB to disk+tape).

Available restore types are:

- Restore from backup media on LAN (standard restore). See ["Standard restore" on page 169](#).
- Split mirror restore. See ["Restore " above](#).
- Instant recovery. See ["Restore " above](#).

Restore types

	Standard restore	Split mirror restore	Instant recovery
ZDB to disk	N/A	N/A	Yes
ZDB to disk+tape	Yes	Yes	Yes
ZDB to tape	Yes	Yes	N/A

Standard restore

Data backed up in ZDB-to-tape and ZDB-to-disk+tape sessions can be restored from the backup media to the application system through a LAN. For more information on this restore type, see the *HPE Data Protector Help* index: "restore".

Tip: You can improve the data transfer rate by connecting a backup device to the application system. For information on configuring backup devices, see the *HPE Data Protector Help* index: "backups devices, configuring". For information on performing a restore using another device, see the *HPE Data Protector Help* index: "selecting, devices for restore".

The procedure below is a general description of restoring the objects backed up in a ZDB session.

1. In the Context List, select **Restore**.
2. Select the objects for restore and click them to display their properties.
In the Scoping Pane, select the application system as **Target client** under the **Destination** tab.
For information on restore options, press **F1**.
3. Click **Restore**. The **Start Restore Session** dialog box appears.

4. Click **Next** to specify the report level and network load. Click **Next**.
5. If the Data Protector EMC Symmetrix Agent is also installed on the *target* client system, select **P9000 XP restore**. Click **Next**.

P9000 XP restore

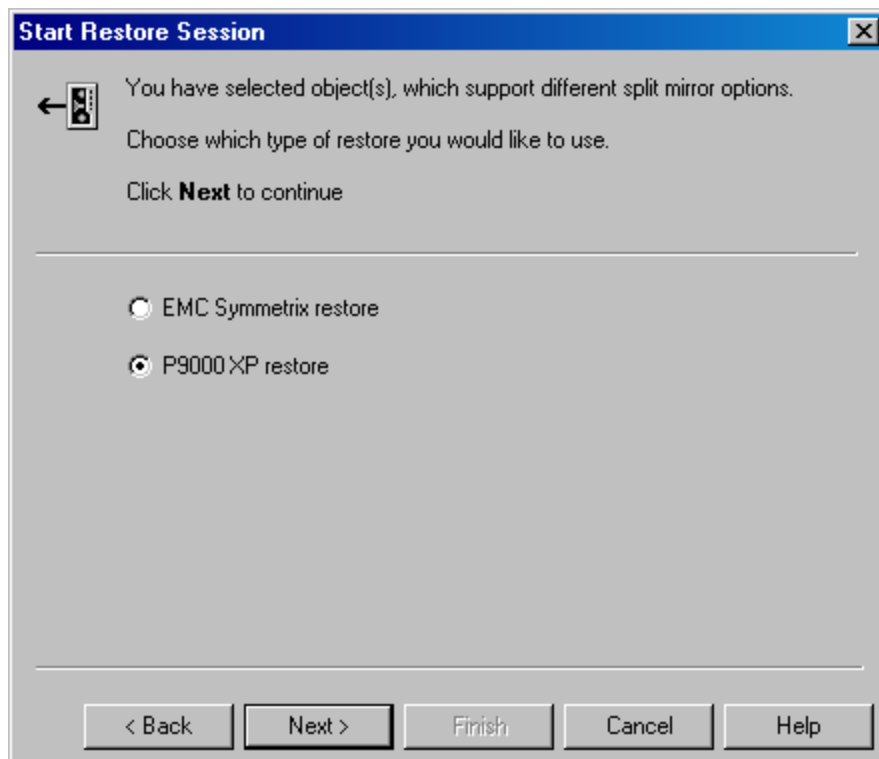

Click **Next**.

6. In the **Start Restore Session** window, select **Disabled** as **Mirror mode**. This sets a direct restore to the application system.
7. Click **Finish** to start the restore.

Split mirror restore

Considerations

- Split mirror restore can be run with both replica types: split mirror and snapshot. The same split mirror restore procedure applies in both cases.
- You can start a split mirror restore session only after the preceding session using the same internal disks on the application system finishes with the disk pairs synchronization (the transition of the LDEV pairs into the PAIR state).

Split mirror restore process

Data is restored from backup media on LAN to the secondary LDEVs (S-VOLs), and then copied to the primary LDEVs (P-VOLs). The process consists of the following automated steps:

1. Applying replica set rotation (if a replica set is defined) to the specified replica set to select the replica for restore. For more information, see the *HPE Data Protector Concepts Guide*.
2. Preparing the application system and the backup system.
3. Restoring data from the backup media on LAN to the backup system and copying this data to the application system.

Split mirror restore procedure

1. In the Context List, select **Restore**.
2. Select the objects for restore and click them to display their properties.

Note: Select the application system as **Target client** under the **Destination** tab. If the backup system is selected, standard restore to the backup system is performed.

3. Click **Restore**. The **Start Restore Session** dialog box appears.
4. Click **Next**.
5. Specify the report level and network load. Click **Next**.
6. If the Data Protector EMC Symmetrix Agent is also installed on the *target* client system, select **P9000 XP restore**. Click **Next**.
7. Specify the split mirror restore options. See "P9000 XP split mirror restore options " below. For more information, see "[Split mirror restore options](#)" on the next page.

P9000 XP split mirror restore options

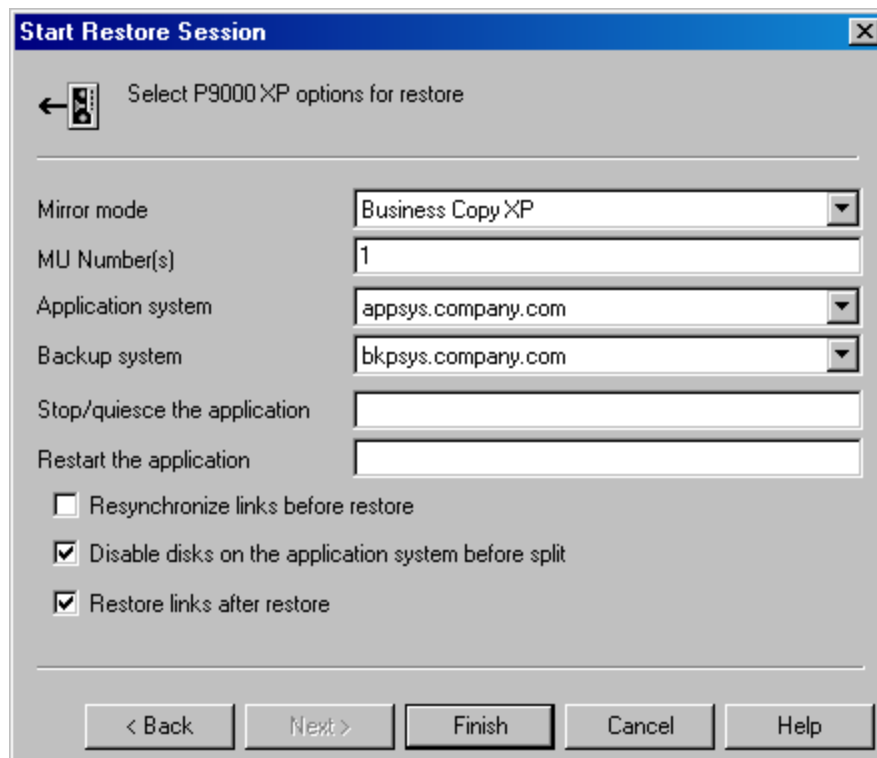

The screenshot shows the "Start Restore Session" dialog box with the following fields and options:

- Mirror mode: Business Copy XP (dropdown)
- MU Number(s): 1 (text input)
- Application system: appsys.company.com (dropdown)
- Backup system: bkpsys.company.com (dropdown)
- Stop/quiesce the application: (empty text input)
- Restart the application: (empty text input)
- Resynchronize links before restore:
- Disable disks on the application system before split:
- Restore links after restore:

Buttons at the bottom: < Back, Next >, Finish, Cancel, Help

8. Click **Finish** to start the split mirror restore.

Note: If LVM mirroring is used, a warning appears during the session, since the volume group LDEVs in the physical volume group on the application system do not have HPE BC P9000 XP pairs assigned. This warning should be ignored.

For information on the general restore process, see the *HPE Data Protector Help* index: “restore”.

Split mirror restore options

The following table explains the split mirror restore options.

Split mirror restore options

Data Protector GUI	Function
Mirror mode	Selects a P9000 XP Array configuration. Only the HPE Business Copy P9000 XP configuration is supported.
MU Number(s)	This option defines the mirror unit (MU) number(s) of a replica or a replica set from which the Data Protector HPE P9000 XP Agent, according to the replica set rotation, selects the replica to be used in the restore session. The replica selection rule is described in the <i>HPE Data Protector Concepts Guide</i> . You can specify one or more non-negative integer numbers, one or more ascending ranges of such numbers, or any combination of both. Use a comma as the separator character. Examples: 5 7-9 4,0,2-3 When a sequence is specified, it does not define the order in which the replicas are used. Default: 0 (nothing is specified).
Application system	Specifies the system to which your data will be restored. In cluster environments, specify the virtual server hostname (rather than the physical node hostname).
Backup system	Specifies the system to which your data will be restored from the backup media on LAN.
Stop/quiesce the application	Optionally specifies the command/script to be run before the LDEV pairs are split (put into the SUSPENDED state). The command/script must reside on the application system in the default Data Protector administrative commands directory. It can be used, for example, for stopping the application,

Data Protector GUI	Function
	<p>dismounting the file systems that are not to be restored in the active session, but belong to the same volume group or disk, or preparing the volume group for deactivation.</p> <p>If this command/script fails, the command/script specified with the option Restart the application is not executed. Therefore, you need to implement a cleanup procedure in this command/script. Note that if the <code>omnirc</code> option <code>ZDB_ALWAYS_POST_SCRIPT</code> is set to 1, the command/script specified with the option Restart the application is always executed. For details, see "ZDB omnirc options" on page 248.</p>
<p>Restart the application</p>	<p>Specifies the command/script to be run immediately after the LDEV pairs are resynchronized (put into the PAIR state). The command/script must reside on the application system in the default Data Protector administrative commands directory. It can be used, for example, for restarting the application or mounting the filesystems.</p>
<p>Resynchronize links before restore</p>	<p>Directs the Data Protector disk array agent to synchronize the LDEV pairs, that is, to copy the application data to the disks which store backup data. This is necessary to prepare the disks for restore and to enable consistent data restore. If the paired LDEVs have been split (put into the SUSPENDED state) before the restore, and only some files need to be restored, then this option updates the backup system. This will ensure that the correct data is resynchronized to the application system. If this option is not selected, the synchronization is not performed.</p> <p>Default: not selected.</p>
<p>Disable disks on the application system before split</p>	<p>Directs the Data Protector disk array agent to disable disks on the application system, that is, dismount the filesystems and deactivate the volume groups. This is performed before the LDEV pairs are split. The disks are enabled after the links are restored. Note that only filesystems selected for restore are dismounted. If other filesystems exist in the volume group or on the disk, appropriate commands/scripts must be used to dismount these filesystems (specified with the options Stop/quiesce the application and Restart the application). You must always select this option for restore when you want to copy data from the backup system to the application system, that is, to incrementally restore links. The application system disks have to be disabled to provide data integrity after the links are restored, that is, data is copied.</p> <p>Default: selected.</p>

Data Protector GUI	Function
Restore links after restore	Directs the Data Protector disk array agent to incrementally restore the links for the LDEVs that Data Protector has successfully restored to the backup system. The HPE P9000 XP Agent also incrementally re-establishes links for the LDEVs for which the Data Protector restore failed. Default: selected.

The chart below provides detailed split mirror restore flow depending on the options selected.

Filesystem split mirror restore flow

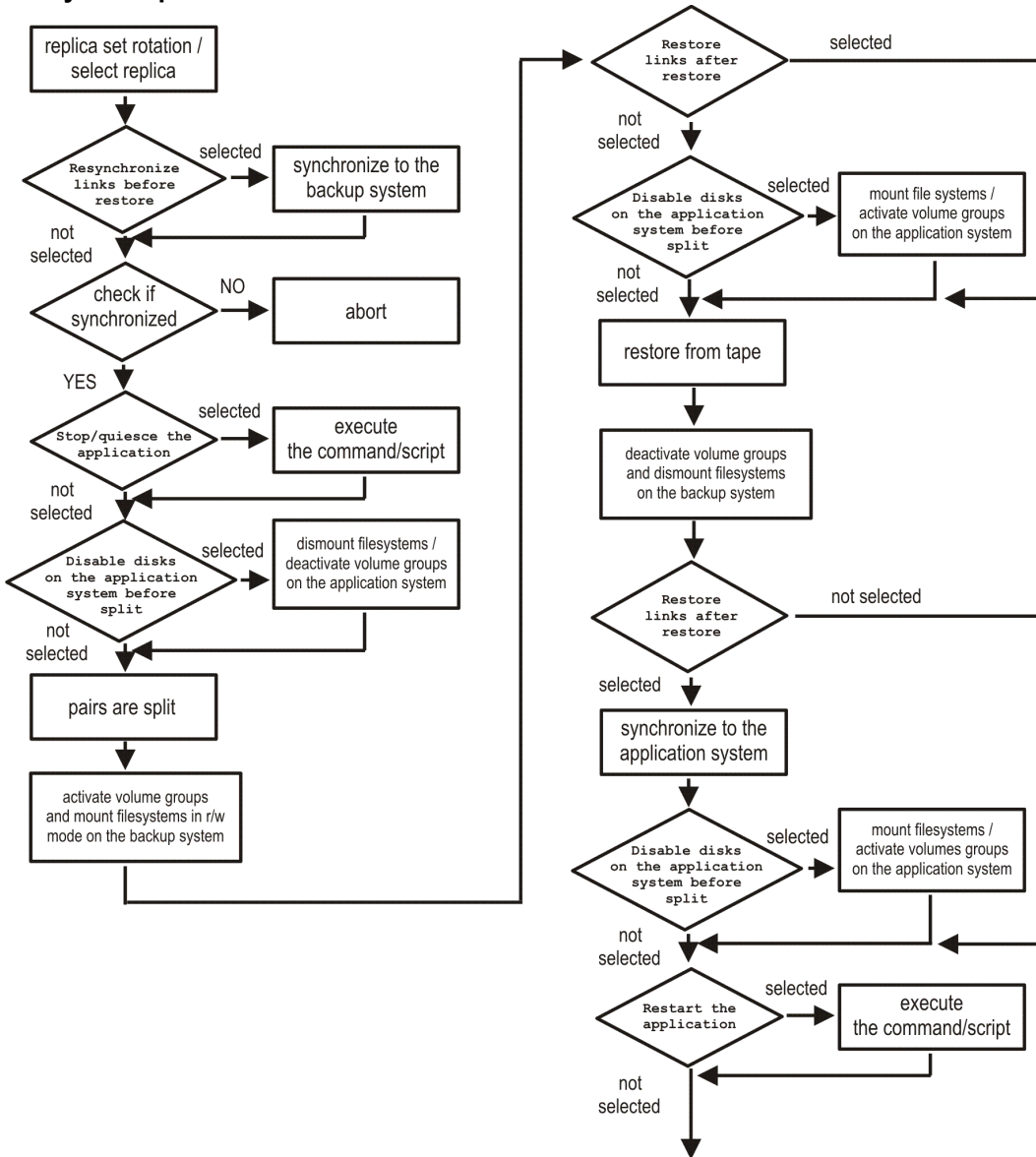

Split mirror restore in a cluster

Split mirror restore in configurations with the application system in HPE Serviceguard or a Microsoft server cluster requires additional steps.

HPE Serviceguard procedure

1. Stop the filesystem cluster package:

```
cmhaltpkg ApplicationPackageName
```

This stops filesystem services and dismounts the mirrored volume group filesystem.
2. Deactivate the mirrored volume group from cluster mode and activate it in normal mode:

```
vgchange -c n /dev/mirror_vg_name  
vgchange -q n -a y /dev/mirror_vg_name
```
3. Mount the mirrored volume group filesystem:

```
mount /dev/mirror_vg_name /lv_name /mountpoint
```
4. Start split mirror restore. For details, see ["Split mirror restore procedure" on page 170](#).
When specifying the application system, specify the hostname of the application system *node* on which the mirrored volume group was activated in the normal mode (["Deactivate the mirrored volume group from cluster mode and activate it in normal mode:"](#) above of this procedure).
5. After the restore, dismount the mirrored volume group filesystem:

```
umount /mountpoint
```
6. Deactivate the mirrored volume group in normal mode and activate it in cluster mode:

```
vgchange -a n /dev/mirror_vg_name  
vgchange -c y /dev/mirror_vg_name
```
7. Start the filesystem cluster package:

```
cmrunpkg ApplicationPackageName
```

Instant recovery

Instant recovery restores data directly from a replica to the source volumes, without involving a backup device. All data (entire volume group on UNIX systems or entire disk on Windows systems) in the replica is restored. For instant recovery concepts, see the *HPE Data Protector Concepts Guide*.

You can perform instant recovery using the Data Protector GUI (see ["Instant recovery using the GUI" on the next page](#)) or CLI (see ["Instant recovery using the CLI" on page 110](#)).

Considerations

- Only first-level mirrors or snapshot volumes can be used for instant recovery. Second-level (cascading) mirrors and snapshot volumes are not supported.
- Instant recovery can be run with both replica types: split mirror and snapshot. The same instant recovery procedure applies in both cases.
- When instant recovery starts, Data Protector disables the application system. This includes

dismounting filesystems and exporting volume groups (on UNIX systems only). Before this is done, filesystems' and volume groups' status is checked, and only mounted filesystems and imported volume groups are dismounted and exported. At the end of the session, dismounted filesystems are mounted and exported volume groups are imported to the same mount points as were used during backup.

- You cannot start several instant recovery sessions using the same disk on the application system at once. A session can be started only after the preceding session using the same source volume on the application system finishes synchronization.

After instant recovery, restored filesystems are mounted to the same mount points/drive letters as they were at the backup time. If these mount points/drive letters have other filesystems mounted, these filesystems are automatically dismounted before instant recovery, and the restored filesystems are mounted afterwards.

For more information about P9000 XP Array instant recovery considerations and limitations, see the HPE Data Protector Product Announcements, Software Notes, and References and the *HPE Data Protector Concepts Guide*.

Instant recovery does not recover databases or applications. It only synchronizes the primary LDEVs on the application system with the secondary LDEVs on the backup system. To recover a database or application data, you need to perform additional steps.

Prior to instant recovery, Data Protector:

- checks the volume group configuration (on UNIX systems only)
- verifies the replica

These steps assure that data in the replica has been left intact after the replica was created. If either of these steps fails, the instant recovery session fails.

Once the replica is restored, it can be left unchanged or resynchronized, depending on the selected instant recovery options. For information, see ["Instant recovery options" on page 110](#).

Instant recovery procedure

Prerequisites

- Before performing a disk image instant recovery, manually dismount the disks before the instant recovery, and re-mount them afterwards.

Instant recovery using the GUI

1. In the Context List, select **Instant Recovery**.
2. Select the backup session whose replica you want to use for instant recovery. This can be done by selecting:
 - a zero downtime backup session ID and the corresponding ZDB backup specification name:
In the Scoping Pane, expand **Restore Sessions** and select the session from a list of ZDB-to-disk and ZDB-to-disk+tape sessions.
 - a backup object type, a ZDB backup specification name, and a ZDB session ID:

- i. In the Scoping Pane, expand **Restore Objects**.
Backup object types are displayed. Examples of backup object types are filesystem, disk Image, SAP R/3, and Microsoft SQL Server.
- ii. Expand the backup object type for which you want to perform instant recovery.
Available backup specifications used in ZDB-to-disk or ZDB-to-disk+tape sessions for the selected backup object type are displayed.
- iii. Expand the ZDB backup specification containing the required objects. Available ZDB sessions are displayed.

Selecting a session for instant recovery

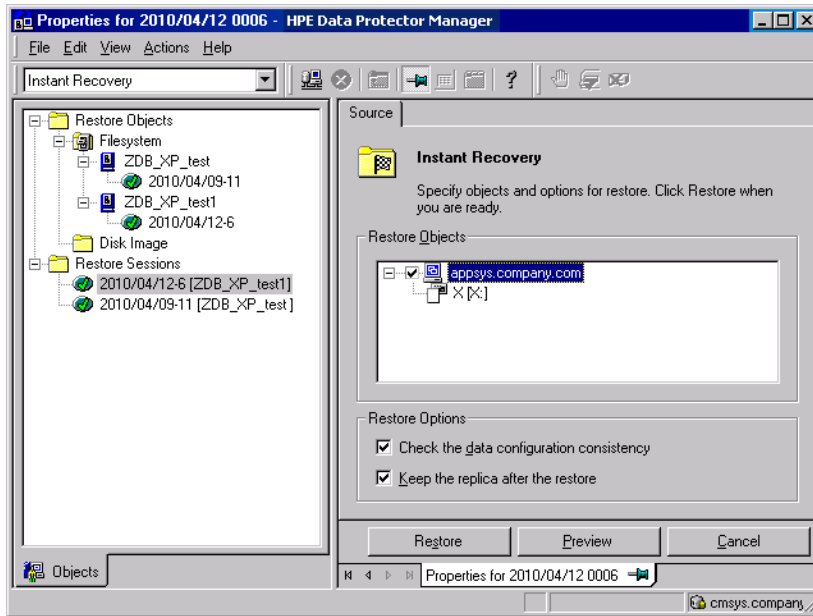

In the Scoping Pane, click the desired ZDB session.

The application system and its mount points/drive letters backed up during the selected session are displayed.

3. Select the application system and specify the instant recovery options. For details, see "[Instant recovery options](#)" on the next page.
4. Click **Restore** to start the instant recovery, or **Preview** to preview it. Note that preview is available only for filesystem backup objects.
5. Select **Start Restore Session** to start instant recovery, or **Start Preview Session** to start the preview. Click **OK**.

Note: You cannot use the CLI to perform instant recovery from ZDB to disk+tape after exporting or overwriting the media used in the session. Use the GUI instead. Note that backup media must not be exported or overwritten even after an object copy session.

Instant recovery using the CLI

1. List all available ZDB-to-disk and ZDB-to-disk+tape sessions, identified by the session ID:

```
omnidbpx -ir -session -list
```

From the output, select the backup session whose replica you want to use for instant recovery.

2. Execute:

```
omnir -host ClientName -session SessionID -instant_restore [INSTANT_RECOVERY_OPTIONS]
```

where the meaning of the options is as follows:

ClientName The application system name.

SessionID The backup session ID ("[List all available ZDB-to-disk and ZDB-to-disk+tape sessions, identified by the session ID:](#)" above of this procedure).

For *INSTANT_RECOVERY_OPTIONS*, see "[Instant recovery options](#)" below.

For further details, see the *HPE Data Protector Command Line Interface Reference* or the omnidbpx and omnir man pages.

Instant recovery options

Instant recovery options

Data Protector GUI/CLI	Function
Check the data configuration consistency/ -check_config	<p>If this option is selected in the GUI or specified in the CLI, the current configuration of the participating volume groups is compared with the volume group configuration as it was during the ZDB session and which is stored in the XPDB. If the configuration has changed since the ZDB session, the instant recovery session aborts. Additionally, the CRC information for the selected LDEV pairs stored in the XPDB is compared to the current CRC information. If the items compared do not match, the instant recovery session aborts. A RAID Manager Library flag, which is set whenever the selected secondary LDEV is accessed/changed by any process (including non-Data Protector processes) is checked. If the flag is set, the session fails with an appropriate warning.</p> <p>HPE Serviceguard clusters: When instant recovery is performed to some other node than the one from where the volumes were backed up, the current volume group configuration on the target node is different from the volume group configuration kept in the XPDB. In such a case, the XPDB volume group configuration data is</p>

Data Protector GUI/CLI	Function
	<p>replaced by the current volume group configuration data on the target node, and the session does not abort. When performing instant recovery to some other node than the one that was backed up, select (GUI) or specify (CLI) this option.</p> <p>Default (GUI): selected.</p>
<p>Keep the replica after the restore/ - keep_version</p>	<p>If this option is selected in the GUI or specified in the CLI, the LDEV pairs involved in the current instant recovery session are split and left in the SUSPENDED state after the restore of data is complete. In the opposite case, the LDEV pairs are left in the PAIR state.</p> <p>Even if the instant recovery is successful, it is recommended to keep the replica until the next ZDB session.</p> <p>Linux systems: This option must be selected (GUI) or specified (CLI) if the replica set consists of more than a single replica.</p> <p>Default (GUI): selected.</p>

Instant recovery and LVM mirroring

If you use an LVM mirroring configuration, perform the following instant recovery steps:

1. Reduce all logical volumes which have LVM mirrors, specifically, reduce or remove the mirrors that reside on primary LDEVs that are not paired with secondary LDEVs on the P9000 XP Array. This ensures that restored data cannot be accidentally overwritten by a synchronization of the LVM mirror.
 Rebuild the LVM mirroring environment to the previous configuration.
2. Start the instant recovery session.
3. Extend the logical volume containing LVM mirroring disks (using the `lvextend -m` command) with the LVM mirror disk that was previously excluded from the logical volume.

Instant recovery in a cluster

For information about and instructions for instant recovery in configurations with the application system in HPE Serviceguard or a Microsoft server cluster, see ["Instant recovery in a cluster" on page 237](#).

Chapter 12: Troubleshooting

Before you begin

This chapter lists general checks and verifications plus problems you may encounter when using the P9000 XP Array integration. For general Data Protector troubleshooting information, see the *HPE Data Protector Troubleshooting Guide*.

- Ensure that the latest official Data Protector patches are installed. For information on how to verify this, see the *HPE Data Protector Help* index: “patches”.
- For general Data Protector and integration-specific limitations, as well as recognized issues and workarounds, see the HPE Data Protector Product Announcements, Software Notes, and References.
- For an up-to-date list of supported versions, platforms, and other information, see <https://softwaresupport.hpe.com/>.

Checks and verifications

- On the application and backup systems, examine system errors logged into the `debug.log` file residing in the default Data Protector log files directory.
- Ensure that RAID Manager Library is correctly installed on the application system and the backup system and is accessible by the HPE P9000 XP Agent, that is, listed in the library path.

General problems

Problem

A process stops responding when attempting to read data from a secondary LDEV (SVOL) in the PAIR state

When a secondary LDEV (S-VOL) is presented to the backup system, the LDEV pair it belongs to is in the PAIR state, and a process attempts to read the data from the secondary LDEV, the process stops responding. If such a problem occurs, all other processes attempting to read the data from such a secondary LDEV, for example the `pvscan` command, are affected, too.

Action

Unpresent the secondary LDEV from the backup system or unzone them.

Caution: Under the described circumstances, you should not try to restart the backup system before resolving the issue. Doing so may result in a data loss due to corruption of the involved file system. If the file system is corrupt, the backup system may even not be able to start up.

Backup problems

Problem

You cannot select the HPE P9000 XP mode in the Data Protector user interface when creating a ZDB backup specification

Action

Check that the HPE P9000 XP Agent integration module is installed on the application and backup systems. To do that, open the `cell_info` file located on the Cell Manager in the following directory:

Windows systems: `Data_Protector_program_data\Config\server\cell\cell_info`

UNIX systems: `/etc/opt/omni/server/cell/cell_info`

File contents should look similar to:

```
-host "sap001.company.com" -os "HPs800 hp-ux-11.10" -cc A.09.00 -da A.09.00 -ssea  
A.09.00
```

```
-host "sap002.company.com" -os "HPs800 hp-ux-11.10" -cc A.09.00 -da A.09.00 -ma  
A.09.00 -ssea A.09.00
```

Problem

On the application system, dismounting of a filesystem fails

Action

In the `Stop/quiesce the application` command line or `Stop/quiesce the application` script, stop all processes using the filesystem.

Use appropriate operating system tools or utilities to get a list of processes that are using the filesystem in order to identify any processes that lock the filesystem. For example, `lsof` on HP-UX.

Problem

On the backup system, mounting of a filesystem fails

Action

Check that the mountpoint directory exists on the backup system and that it is writable. On Windows Server 2003 and Windows Server 2008 systems, if the option **Automatically dismount the file systems on the application system** is selected, check if any processes are locking the filesystem.

Problem

Pair synchronization fails (the split fails)

To successfully split the pair, the HPE P9000 XP Agent first checks its status. Pairs can only be split (in PSUS/SSUS status) after they are synchronized (in PAIR status). HPEP9000 XP Agent checks the status of links after every 2 seconds and retries 10 times.

Action

Increase the time frame for synchronization by setting `SSEA_SYNC_RETRY` and `SSEA_SYNC_SLEEP_TIME` options.

For more information, see ["Appendix" on page 228](#).

Problem

P-VOL has no paired S-VOL

Action

Check the P9000 XP Array configuration as follows:

HPE BC P9000 XP: All P-VOLs on the application system must have associated HPE BC P9000 XP S-VOLs on the backup system.

HPE CA P9000 XP: All P-VOLs on the application system must have associated HPE CA P9000 XP S-VOLs on the backup system.

HPE CA+BC P9000 XP: All P-VOLs on the application system must have associated HPE CA P9000 XP S-VOLs on the backup system and all S/P-VOLs must have HPE BC P9000 XPS-VOLs.

Problem

Invalid pair state of LDEVs

Action

Check the link state. If the link is split, use the **Prepare/resync the mirror disks at the start of the backup** option.

Configure and start RAID Manager P9000 XP instances manually. You can get a list of LDEVs from the backup session report. Alternatively, with newer models of the HPE P9000 XP Disk Array Family, you can use also HPE P9000 XP Remote Web Console (formerly known as HPE Command View XP).

Problem

Missing details for a specific LDEV/MU# are reported

```
[Warning] From: SSEA@machine_app.company.com ""  
Time: 17.10.2008. 10:41:27  
Failed to get a BC pair for LDEV 55, MU# 1 in RAID 35371.  
(Details unknown.)  
[Normal] From: SSEA@machine_app.company.com "" Time: 17.10.2008.  
10:41:27  
Resolving of backup objects on the application system completed.  
[Normal] From: SSEA@machine_bu.company.com "" Time: 17.10.2008. 10:41:27  
Resolving backup objects on the backup system.  
[Critical] From: SSEA@machine_bu.company.com "" Time: 17.10.2008. 10:41:29  
Resolving of backup objects on the backup system failed.
```

Action

1. In the backup specification, specify an existing and configured LDEV/MU# on the backup system, or ensure that LDEV/MU# stated in the output is not set in the P9000 XP LDEV exclude file.
2. Restart the session.

Problem

Filesystems not resolved on the backup system

On Windows systems, in some initial configurations filesystems may not be resolved on the backup system. The filesystems do not show up at all, even after a manual pair or split operation is performed on the disk array.

Action

Using the device manager, remove the problematic disks from the disk array and rescan the backup system.

Problem

During a zero downtime backup session, when a second replica is selected from the replica set specified by the ZDB backup specification option MU number(s), the session fails

If more than one replica is specified in the ZDB backup specification option **MU number(s)**, and a ZDB session is run which, according to the replica selection rule, selects the second or any subsequent replica, the session fails.

Action

The problem may be related to the duplicate disk signatures assigned to the target volumes by the Windows operating system.

Perform the following:

1. Unpresent all involved target volumes from the backup system.
2. On the backup system, clean the Registry.

Windows Server 2003: Run the Scrubber utility by invoking the `scrubber2003` command. You can download Scrubber from the website <http://support.microsoft.com/kb/277222/>.

Windows Server 2008: Run the DiskPart utility by invoking the `diskpart` command. Inside the DiskPart shell, execute the command `automount scrub`.

3. Put all involved P-VOL - S-VOL pairs into the SUSPENDED state.
4. Present the target volumes to the backup system.
5. Start the ZDB session once again.

Problem

A warning message is displayed in the Windows event logs when using the P9000 XP Array with two or more MU number(s).

If two or more **MU number(s)** are used with P9000 XP Array, a warning message is displayed in the Windows event logs.

Action

No action is required as this warning does not have a negative impact on the backup. The warning message appears when more than one mirror of the same disk is present on a Windows system.

Split mirror restore problems

Problem

Session fails with the following message:

```
[Major] From: SSEA@machine.company.com "" Time: 17.10.2008. 11:06:46
Filesystem /dev/bc_nested/hfs could not be dismounted from
/BC/fs/HFS/usr/sbin/vgchange -a n /dev/bc_nested
[Major] From: SSEA@machine.company.com "" Time: 17.10.2008. 11:06:47
[224:8]Volume group /dev/bc_nested could not be deactivated.
```

Action

Ensure that the filesystem/volume group is not in use (you are positioned in the filesystem mountpoint directory), and then restart the session.

Problem

LDEV pair is in “STAT_COPY” state when split mirror restore starts, and the session fails with:

```
[Critical] From: SSEA@machine.company.com "" Time: 16.10.2008. 17:25:00
The following BC pairs have an invalid status for the requested operation:
SEQ#    LDEV          Port    TID  LUN  MU#  Status    SEQ#    LDEV
-----
35371   00A8h ( 168)  CL1-D   1    3    0  STAT_COPY 35371   01A5h
( 421)
35371   00A8h ( 168)  CL1-D   1    3    0  STAT_COPY 35371   01A6h
( 422)
-----
[Critical] From: SSEA@machine.company.com "" Time: 16.10.2008. 17:25:00
Failed to resolve objects for Instant Recovery.
```

Action

Wait until the LDEV pair is in “PAIR” or “PSUS/SSUS” status, and then restart the session.

Instant recovery problems

Problem

LDEV pair is in “STAT_COPY” state when split mirror restore starts, and the session fails with:

[Critical] From: SSEA@machine.company.com "" Time: 16.10.2008. 17:25:00
The following BC pairs have an invalid status for the requested operation:

SEQ#	LDEV	Port	TID	LUN	MU#	Status	SEQ#	LDEV
35371	00A8h (168)	CL1-D	1	3	0	STAT_COPY	35371	01A5h (421)
35371	00A8h (168)	CL1-D	1	3	0	STAT_COPY	35371	01A6h (422)

[Critical] From: SSEA@machine.company.com "" Time: 16.10.2008. 17:25:00
Failed to resolve objects for Instant Recovery.

Action

Wait until the LDEV pair is in "PAIR" or "PSUS/SSUS" status, and then restart the session.

Part 4: HPE 3PAR StoreServ Storage

This part describes how to configure the Data Protector HPE 3PAR StoreServ Storage integration, and how to perform zero downtime backup and instant recovery using the HPE 3PAR StoreServ Storage integration through native storage system support built-in in the Data Protector HPE P6000 / HPE 3PAR SMI-S Agent. For information on how to perform zero downtime backup and instant recovery using the HPE 3PAR StoreServ Storage integration through the Data Protector Microsoft Volume Shadow Copy Service integration, see the *HPE Data Protector Integration Guide for Microsoft Volume Shadow Copy Service*.

Chapter 13: Configuration

Introduction

This chapter lists prerequisites and limitations of the Data Protector HPE 3PAR StoreServ Storage integration when implemented with the Data Protector HPE P6000 / HPE 3PAR SMI-S Agent, and configuration steps that should be followed when the integration is implemented with either of the supporting Data Protector integration agents: HPE 3PAR VSS Agent or HPE P6000 / HPE 3PAR SMI-S Agent.

Prerequisites

- Obtain or install:

Data Protector licenses and components:

- Appropriate zero downtime backup extension and instant recovery extension licenses-to-use (LTU).
- Backup and Application hostname should match the name of the host on 3PAR as seen from 3PAR Management console or by running 3PAR CLI command showhost. The hostname is case-sensitive.
- HPE P6000 / HPE 3PAR SMI-S Agent installed on both the application system and the backup system.
- An appropriate multi-path device management software.

The software must be installed on the application system and the backup system.

HP-UX systems: HPE Secure Path

On HP-UX 11.31 systems, the multi-path device management software is not required since the operating system has native device multi-pathing capability.

Linux systems: HPE Device Mapper Multipath Enablement Kit for HPE Disk Arrays 4.2.0 or newer version.

To configure the installed multi-path device management software:

- i. Start the multipath daemon and run the following command to configure the daemon so that it gets started during system startup:

Red Hat Enterprise Linux: `chkconfig multipathd on`

SUSE Linux Enterprise Server: `chkconfig boot.multipath on`

- ii. Prevent the multipath device management software from queuing for unavailable disk volumes by modifying its configuration file.

Add the following line into the defaults section of the file `/etc/multipath.conf`:

```
no_path_retry          fail
```

Ensure that this `no_path_retry` parameter value is not overridden by analogous entries in the `device` sections of the same file in which the corresponding HPE 3PAR storage systems are configured.

- iii. Ensure that the correct preferred names are used for pathnames that are referencing the same device for physical volumes as they are used in `device-mapper` multipathing.

Open the `lvm.conf` file, residing in the `/etc/lvm/` directory, and set the following variable:

```
preferred_names = [ "^/dev/mpath/", "^/dev/mapper/mpath", "^/dev/[hs]d" ]
```

Windows systems: Microsoft MPIO configured for HPE 3PAR Storage. For more information, see the *HPE 3PAR Windows Implementation* guidelines.

For licensing information and installation and upgrade instructions, see the *HPE Data Protector Installation Guide*.

- Make sure the same operating system version is installed on both the application system and the backup system.
- If the application system and the backup system reside in a Data Protector cell with secured clients, ensure that access between both systems is allowed in both directions.
- Connect a storage system of the HPE 3PAR StoreServ Storage family to the application and backup systems through the SAN. The backup system must be connected to the same SAN as the storage system of the HPE 3PAR StoreServ Storage family.
- Source volumes must have *snapshot space (copy space)* in a storage system's Common Provisioning Group (CPG) associated with.
- You can specify a disk image section in two ways: the first way selects a particular volume, and the second way selects an entire disk. In case of ZDB, you must use the second way:
 - `\\.\DriveLetter:`, for example: `\\.\E:`

Note: When a drive letter is specified for the volume name, the volume is not being locked during the backup. A volume that is not mounted or mounted as an NTFS folder cannot be used for disk image backup.

- `\\.\PHYSICALDRIVE#`, where `#` is the current number of the disk you want to back up. For example: `\\.\PHYSICALDRIVE3`

Limitations

- In cluster environments, the backup system must not be in the same cluster with the application system. Additionally, the backup system cannot be the cluster virtual server, it can only be a cluster node.
- If replica is tracked for instant recovery, the volumes that are made active by applying either the "Host set" or the "Port presents" VLUN template types, cannot be used as source volumes.

For information on either of the following items, see the HPE Data Protector Product Announcements, Software Notes, and References:

- General Data Protector and integration-specific limitations
- Supported platforms and integrations
- Supported backup and connectivity topologies

Configuring the integration

Before you start with the configuration, make sure the prerequisites listed in ["Introduction" on page 119](#) (for HPE P6000 / HPE 3PAR SMI-S Agent) or in the *HPE Data Protector Integration Guide for Microsoft Volume Shadow Copy Service* (for HPE 3PAR VSS Agent) are fulfilled.

To prepare the Data Protector HPE 3PAR StoreServ Storage integration for use with a storage system of the HPE 3PAR StoreServ Storage family, you must perform the mandatory configuration step. In this step, you need to provide a Data Protector HPE 3PAR StoreServ Storage integration agent the data which the agent will use to establish connection to a Common Information Model Object Manager (CIMOM) provider of your choice. To integrate with this storage system family, Data Protector can use HPE3PAR VSS Agent and P6000 / HPE 3PAR SMI-S Agent (hereafter both referred to as **Data Protector HPE 3PAR StoreServ Storage integration agent**).

CIMOM provider connection configuration

The connection configuration data includes user credentials that you must add to the ZDB database (the 3PAR StoreServ part of SMISDB) in advance, before running Data Protector instant recovery (IR) sessions. The credentials are bound to a specific application system in the Data Protector cell. The Data Protector HPE 3PAR StoreServ Storage integration agent then reads the credentials from the ZDB database each time a zero downtime backup or instant recovery session for data residing on a 3PAR StoreServ system is started.

Connection configuration data

To be able to connect to a CIMOM provider and perform zero downtime backup or instant recovery sessions, the Data Protector HPE 3PAR StoreServ Storage integration agent needs the following information:

- Fully qualified domain name or IP address of the system where the CIMOM service is running
In case the system has multiple IP addresses configured, the address by which the system can be accessed by the Data Protector ZDB agent should be used.
- Whether the connection uses Secure Sockets Layer (SSL)
- Port number of the port on which the CIMOM service is accepting requests
- Username and password

These credentials must belong to a 3PAR StoreServ system user account with the *Edit* privilege level in the following 3PAR StoreServ system virtual domains, depending on the effective disk array configuration:

- Domain of the application system and the source volumes—When the source volumes and the application system belong to a specific domain
- All domains of a domain set—When the application system and the source volumes belong to this domain set
- All existing domains—When the application system and the source volumes do not belong to any domain

For more information on using the HPE 3PAR StoreServ Storage authorization system, see the HPE 3PAR StoreServ Storage documentation.

The above information should be provided in advance for each CIMOM provider that the Data Protector HPE 3PAR StoreServ Storage integration agent should connect to. It is stored in the HPE 3PAR StoreServ Storage part of the SMISDB.

Configuration procedure

To add the required user credentials for an application system where the CIMOM service is running, use the Data Protector `omnidbzd` command. Follow the steps:

1. Identify the source volumes that will be involved in the ZDB-to-disk or ZDB-to-disk+tape sessions.
2. Identify the 3PAR StoreServ system virtual domains or domain set to which the application system and the source volumes belong.
3. Choose a disk array user account that has a proper privilege level on the corresponding domains. Identify and write down its username and password that you will need in the next step.
4. Using the `omnidbzd --diskarray 3PAR --ompasswd --add` command, add the username and password that you acquired in the previous step to the ZDB database, providing the name of the application system you identified in "[Identify the source volumes that will be involved in the ZDB-to-disk or ZDB-to-disk+tape sessions.](#)" above of this procedure.

For command syntax and usage examples, see the `omnidbzd` reference page in the *HPE Data Protector Command Line Interface Reference* or the `omnidbzd` man page.

5. Using the `omnidbzd --diskarray P10000 --ompasswd --check` command (for HPE 3PAR VSS Agent) or the `omnidbzd --diskarray 3PAR --ompasswd --check` command (for HPE 3PAR VSS Agent or HPE P6000 / HPE 3PAR SMI-S Agent), verify that the Data Protector HPE 3PAR StoreServ Storage integration agent can connect to the disk array using the configured user authentication data.

Tip: For each application system, you can add user credentials of multiple disk array user accounts. When several are configured for the same system, the Data Protector HPE 3PAR StoreServ Storage integration agent checks user accounts in alphabetical order and uses the first account with *Edit* privilege level on the application system and the source volumes.

For information on performing other tasks related to management of user credentials in the ZDB database, see the `omnidbzd` reference page in the *HPE Data Protector Command Line Interface Reference* or the `omnidbzd` man page.

Chapter 14: Backup

Zero downtime backup sessions that involve a storage system of the HPE 3PAR StoreServ Storage family can be initiated:

- Through the Data Protector Microsoft Volume Shadow Copy Service integration — if the application and backup systems are running on a Windows operating system, and have the Data Protector HPE P6000 / HPE 3PAR SMI-S Agent installed
- Natively — if the application and backup systems are running on Windows or UNIX operating system and have the Data Protector HPE P6000 / HPE 3PAR SMI-S Agent installed

For information about the supported configurations, ZDB types and replication techniques available on this storage system family, and storage system-specific ZDB considerations, see the *HPE Data Protector Concepts Guide*.

For additional storage system-specific ZDB considerations, procedure for configuring ZDB backup specifications, and instructions for running ZDB sessions, see the *HPE Data Protector Integration Guide for Microsoft Volume Shadow Copy Service*.

ZDB types

Using the HPE 3PAR StoreServ Storage integration through the Data Protector HPE P6000 / HPE 3PAR SMI-S Agent, you can perform all zero downtime backup types:

- **ZDB to disk**

The replica produced is kept on a disk array until reused. This replica becomes part of the replica set and can be used for instant recovery.

ZDB to disk is performed if the option **Track the replica for instant recovery** is selected in a ZDB backup specification, and **To disk** is selected when running/scheduling a backup.

- **ZDB to tape**

The replica produced is streamed to backup media, typically tape, according to the tape backup type you have selected (Full, Incr, Incr1-9).

This replica is deleted after backup if the option **Keep the replica after the backup** is cleared for the backup specification. If this option is selected, the replica remains on a disk array until reused and becomes part of the replica set. However, it cannot be used for instant recovery.

- **ZDB to disk+tape**

The replica produced is kept on a disk array until reused and is also streamed to backup media according to the tape backup type you have selected (Full, Incr, Incr1-9). This replica becomes part of the replica set and can be used for instant recovery.

ZDB to disk+tape is performed if the option **Track the replica for instant recovery** is selected in a ZDB backup specification, and **To disk+tape** is selected when running/scheduling a backup.

For more information on the ZDB types, see the *HPE Data Protector Concepts Guide*.

ZDB for HPE 3PAR Remote Copy environments

HPE 3PAR Remote Copy Software provides enterprise and cloud data centers with autonomic replication and disaster recovery technology that allows the protection and sharing of data from any application simply, efficiently, and affordably.

In the Remote Copy environments, the 3PAR storage system containing source volumes is known as a **local (primary) disk array**, while the 3PAR storage system on which the replicas are created is a **remote (secondary) disk array**. The mirrored source and target volumes constitute a **copy set**. Remote copy configurations are based on the relationship between a pair of storage systems, known as the remote copy pair. Within a remote copy pair, the primary storage system is the system that holds the volumes that are copied to the backup storage system.

Data Protector allows you to perform zero downtime backups of the 3PAR Remote Copy replica. The data backed up in HPE 3PAR remote copy configurations can be restored using either instant recovery or the standard Data Protector restore from tape procedure.

Supported HPE 3PAR Remote Copy Configurations

3PAR Remote Copy Configuration	Supported by Data Protector
1-to-1	Yes
N-to-1	No
1-to-N	No

Data Protector supports the 1-to-1 configuration only. A 1-to-1 remote copy configuration consists of a single remote copy pair. Both unidirectional and bidirectional 1-to-1 configurations.

For more information on 1-to-1 configurations, see the *HPE 3PAR Remote Copy Software User Guide*.

HPE 3PAR Remote Copy Modes

Data Protector supports Synchronous and Periodic modes. The modes supported are briefly explained below.

Synchronous Mode

When remote-copy volume groups operate in synchronous mode, a host write must be committed to both the primary and the backup storage systems before the primary array acknowledges the host write. Remote copy in synchronous mode is illustrated below.

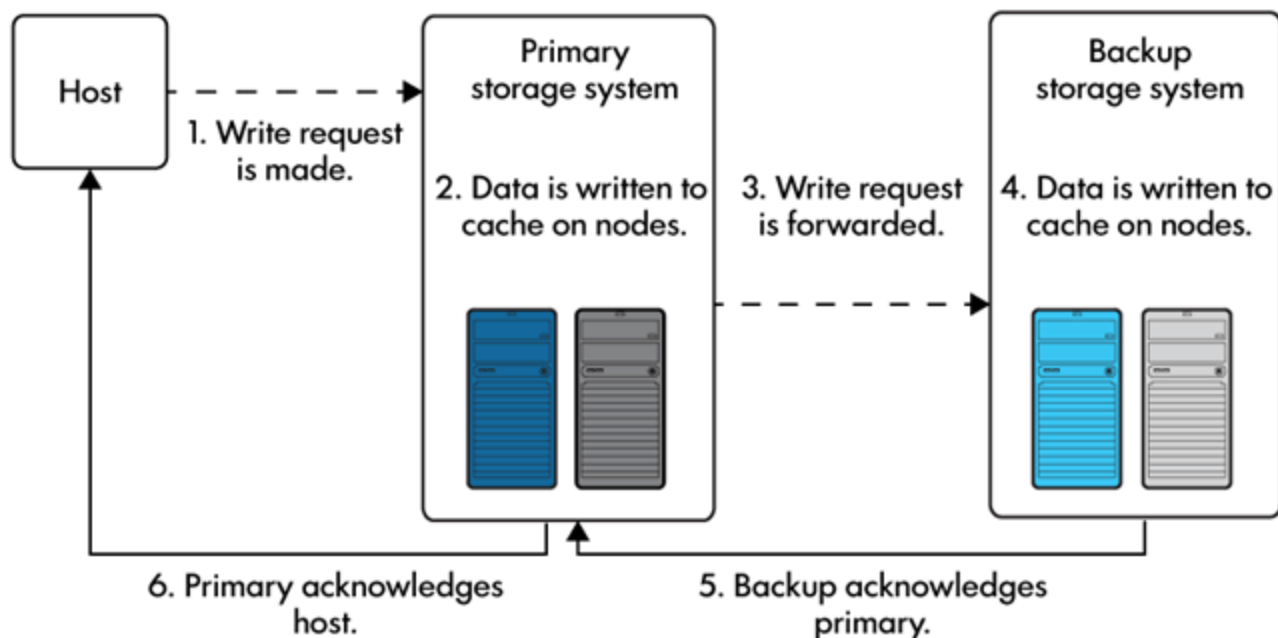

Periodic Mode

When remote-copy volume groups operate in periodic mode, the host sends a write request to the primary system. As soon as the data is written into cache on the primary system, HPE 3PAR Remote Copy acknowledges the host write. Remote copy in period mode is illustrated below. The data will be synchronized to the backup system during the scheduled periodic time interval, or during the manual sync operation.

In the periodic mode, before creating the replica, the sync operation is triggered to sync the data between the primary and secondary storage volumes. If the sync operation is not complete within specified duration of time, backup of the volume is ignored.

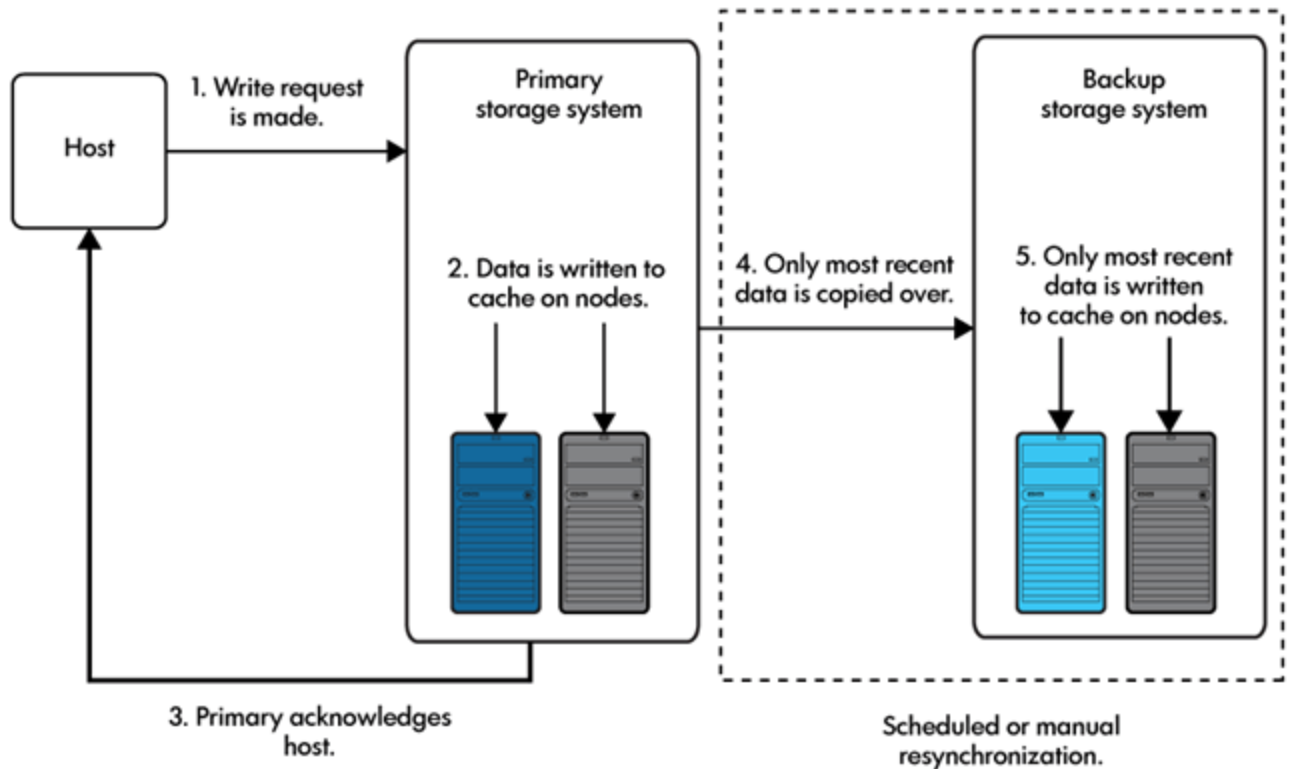

HPE ZDB 3PAR Remote Copy scenarios

HPE 3PAR Remote Copy enables the following backup scenarios:

- Ideal, or non-failover scenarios, where replicas are always created on the array remote to *primary*.

A non-failover scenario

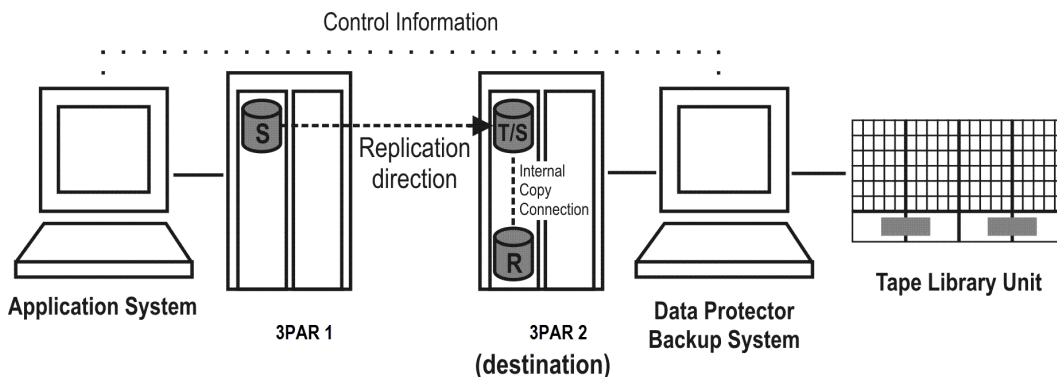

- Failover scenarios, where the roles of original source and destination are reversed after a failover. Replicas in such scenarios can be created:
 - On the disk array remote to the current source (**Follow direction of replication** backup option selected in the backup specification). It means that after a failover, the replication direction is reversed and the replicas are created on the array that was originally a source 3PAR array. ["Failover scenario 1" on the next page](#) depicts an environment where the location of replica

creation was switched after a failover.

Failover scenario 1

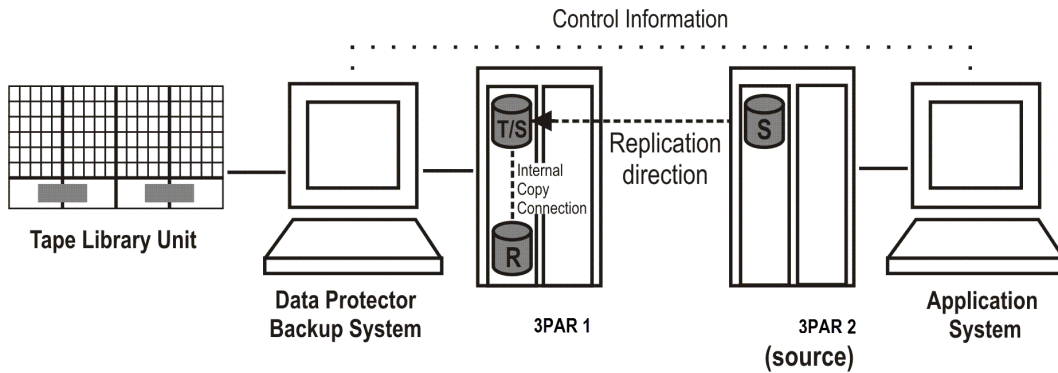

- On the array remote to primary (**Maintain replica location** backup option is selected in the backup specification). It means that after a failover, replica location is maintained and replicas continue on the destination array that has now become a source array. Note that for the time of replica creation, the source array performance may be affected.

Failover scenario 2

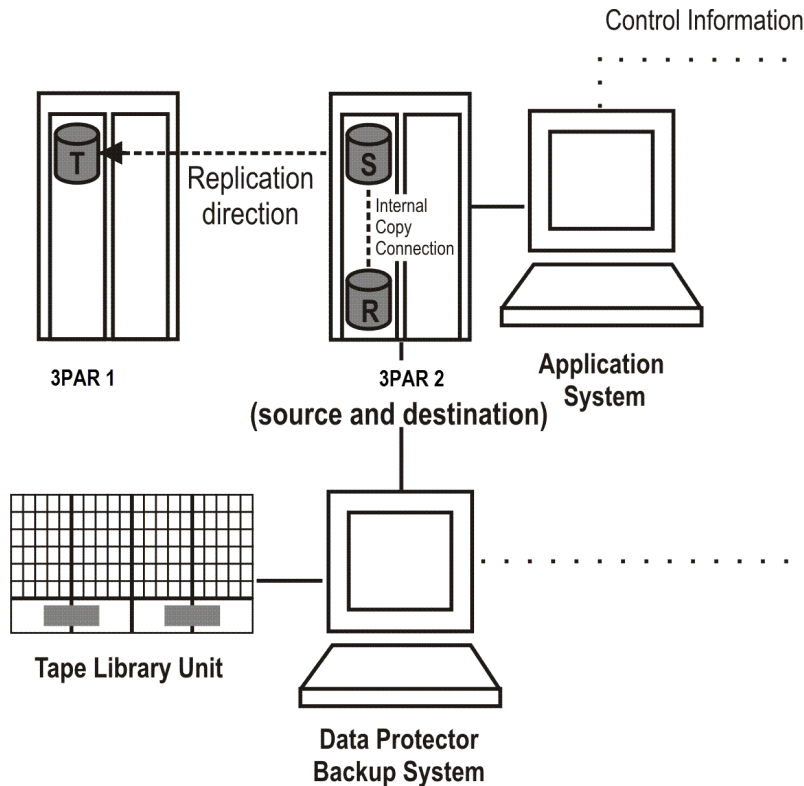

Consider the following:

- If you intend to always follow the replication direction, make sure the backup system has access to both local and remote 3PAR array storage systems. Otherwise, after a failover, ZDB session fails

because the replication direction switches and the backup system is no longer visible to the array where the replicas are created.

Replica set rotation

In the HPE 3PAR Remote Copy non-failover scenarios, replicas are always created on the array remote to primary. If the existing replica count (on the array where new replicas are) exceeds the specified number of replicas rotated, the oldest replica is deleted and the new one is created in its place (ensuring the maximum number of replicas is always within the defined rotation set).

In the HPE 3PAR Remote Copy failover scenarios, replicas are created either on:

- The array remote to current source (or on the primary disk array)
- The array remote to primary

In the first case, the number of replicas in a rotation set is only checked on the current destination array. The replicas created on the current source, which was a destination before a failover, are ignored. Therefore, there are situations when two replica sets are created on both the source and destination arrays.

In the second case, replica set rotation verification happens in a normal way.

Note: Replica rotation set is only created if you select the option **Keep the replica after the backup** and specify **Number of replicas rotated**. Without these options specified, the replica is deleted from the array after the backup to tape is completed.

For more information about replica set rotation, see the *HPE Data Protector Concepts Guide*.

Limitations

- Consider all the limitations that apply to the Data Protector HPE 3PAR StoreServ Storage integration. See the HPE Data Protector Product Announcements, Software Notes, and References, the *HPE Data Protector Concepts Guide*, and the limitations list in "[Introduction](#)" on [page 119](#).
- The selected volumes are backed up only if the remote copy group is in the *Start* state.
- If a switchover operation is performed on the 3PAR remote copy groups, the roles of primary and secondary array are reversed. Data Protector does not consider this as a remote copy group failover, and continues to create the replica on the secondary array even after the switchover operation.

ZDB in HP-UX LVM mirroring environments

For more information, see "[ZDB in HP-UX LVM mirroring environments](#)" on [page 38](#).

Creating the backup specification

This section guides you through the process of configuring a ZDB backup specification for backing up data that resides on a storage system of the HPE 3PAR StoreServ Storage family.

Data Protector 3PAR Remote Copy Omnirc Variables

Data Protector performs a periodic sync operation before the backup is executed. This periodic sync may take more time if your arrays span across different data centers. Therefore, you can use the below omnirc variables to set the wait time, and retry count for the periodic sync operations. Note that if the sync is not completed, the backup session may be aborted.

- ZDB_WAIT_FOR_PERIODIC_SYNC_TO_COMPLETE
 - This variable sets the time period for the remote copy group periodic sync to complete.
 - Default value: 300 seconds, for Windows and Linux.
- ZDB_WAIT_FOR_PERIODIC_SYNC_RETRY_COUNT
 - This variable sets the number of retries to check the status of the remote copy periodic sync completion.
 - Default value: 1

Procedure

1. In the Context List, select **Backup**.
2. In the Scoping Pane, expand **Backup Specifications**. Right-click **Filesystem** (for both object types: filesystem and disk image) and click **Add Backup**.

The Create New Backup dialog box appears.

In the Filesystem pane, select the **Blank Filesystem Backup** template or some other template which you might have created. For information on templates, see the *HPE Data Protector Help* index: "backup templates".

Select **Snapshot or split mirror backup** as **Backup type** and **HPE 3PAR** as **Sub type**. For description of options, press **F1**.

Click **OK**.

3. Under Client systems, select **Application system** and **Backup system**. If the application system is part of a server cluster, select the virtual server.

Under Replication mode, select **HPE 3PAR Local Copy** or **HPE 3PAR Remote Copy**, based on your requirements. If you select HPE 3PAR Remote Copy, specify the choice for replica handling during failover scenarios. See [Backup Options](#) for more information.

Under Snapshot management options, **Virtual copy** is preselected for the snapshot type and cannot be changed.

3PAR StoreServ Storage zero downtime backup options

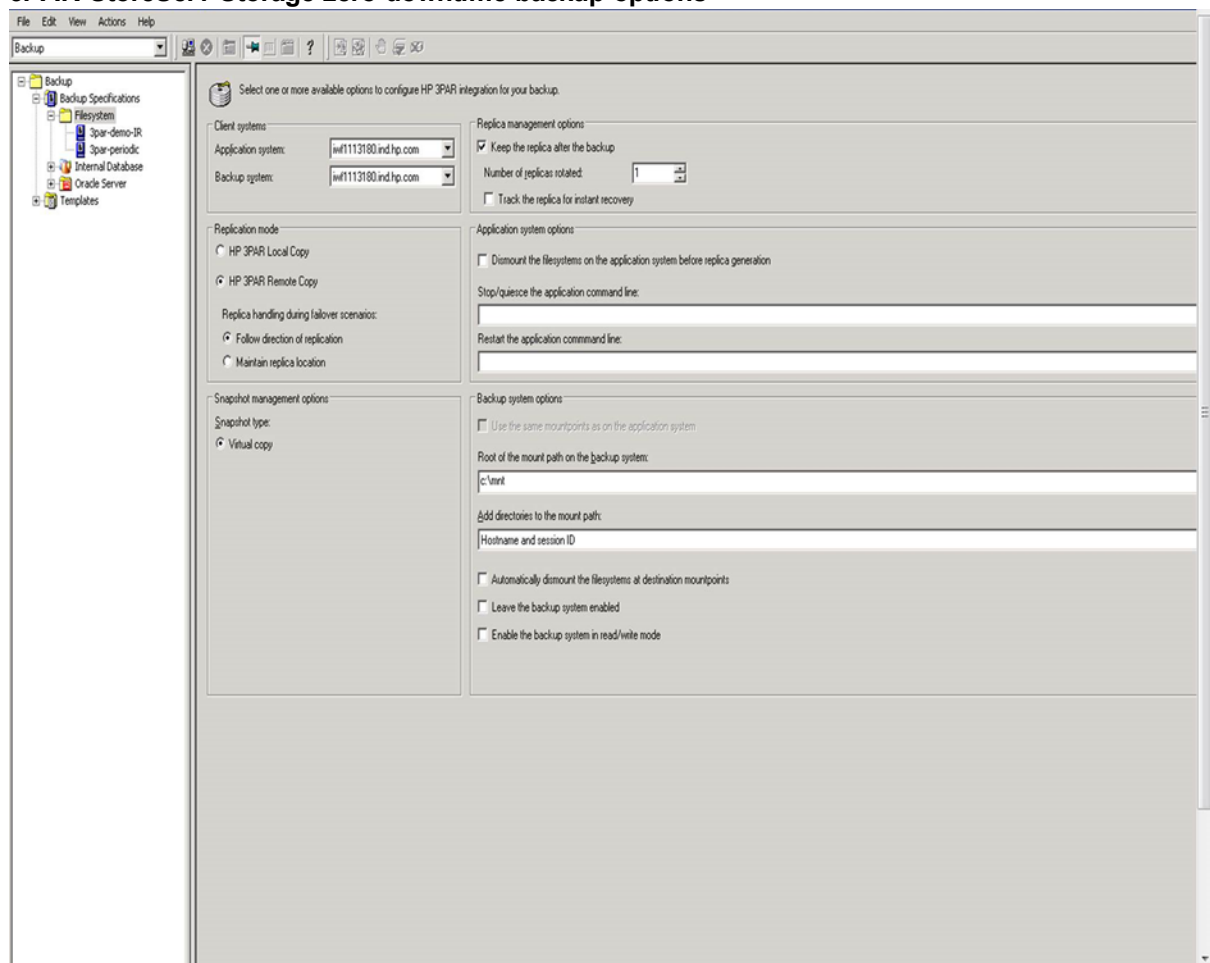

- Under Replica management options, specify if you want to keep the replica after backup, the number of rotated replicas, and whether to track the replica for instant recovery. For more information, press **F1**.
- Under Application system options and Backup system options, specify other zero downtime backup options as desired. For information, see "[Backup options](#)" on the next page or press **F1**.
Click **Next**.
- Select the desired backup objects.
Filesystem backup: Expand the application system and select the objects to be backed up. Note that all drive letters or mount points that reside on the system are displayed. You must select only the objects that reside on the disk array, otherwise the ZDB session fails.
In remote copy backups, if local volumes are selected, the ZDB session falls back to the local copy for the selected local volumes. A warning will be displayed for the same.
Click **Next**.
Disk image backup: Click **Next**.
- Select the devices to be used in the backup session.

To create additional copies (mirrors) of the backup image, specify the desired number of mirrors by clicking **Add mirror** or **Remove mirror**. Select separate devices for the backup image and each mirror.

For information on object mirroring, see the *HPE Data Protector Help* index: "object mirroring".

Click **Next**.

8. In the Backup Specification Options group box, click **Advanced** and then the **HPE3PAR** tab to open the options pane with HPE 3PAR StoreServ Storage specific backup options.

You can specify Application system options and modify all other options, except **Application system** and **Backup system** (note that you can change them after you save the ZDB backup specification). See "[Backup options](#)" below or press **F1**.

Click **Next**.

9. Following the wizard, open the scheduler to schedule the ZDB sessions. For more information, see "[Appendix](#)" on page 228 or press **F1**.

Click **Next**.

10. In the **Backup Object Summary** page, specify additional options.

Filesystem backup: You can modify options for the listed objects by right-clicking an object and then clicking **Properties**. For information on the object properties, press **F1**.

Disk image backup: Follow the steps:

- a. Click **Manual add** to add disk image objects.
- b. Select **Disk image object** and click **Next**.
- c. Select the client system. Optionally, enter the description for your object. Click **Next**.
- d. Specify General Object Options and Advanced Object Options. For information on these options, press **F1**.
- e. In the Disk Image Object Options window, specify disk image or raw logical volume sections.

Specify a disk image section:

`/dev/rdisk/FileName`, for example: `/dev/rdisk/c2t0d0`

On HP-UX 11.31 systems, the new naming system can be used:

`/dev/rdisk/disk#`, for example `/dev/rdisk/disk2`

Specify a raw logical volume section:

`/dev/vgnumber/r1volNumber`, for example: `/dev/vg01/r1vol1`

- f. Click **Finish**.

Click **Next**.

11. Save your ZDB backup specification.

Backup options

The following tables describe the ZDB-related backup options that you can modify when configuring ZDB backup specifications that include storage systems of the HPE 3PAR StoreServ Storage family.

Client systems

Application system	The system on which the application runs. In cluster environments, specify the virtual server hostname (rather than the physical node hostname).
Backup system	The system to which your data will be replicated (backed up), and from which the backup data is copied to a backup device.

Replica management options

Keep the replica after the backup	<p>If configuring a ZDB to tape, select this option to keep the replica on the disk array after the zero downtime session. The replica becomes part of a replica set (specify a value for the option Number of replicas rotated). Unless the additional option Track the replica for instant recovery is selected, the replica is <i>not</i> available for instant recovery.</p> <p>If this option is not selected, the replica is removed at the end of the session.</p> <p>If the option Track the replica for instant recovery is selected, this option is automatically selected and cannot be changed.</p>
Number of replicas rotated	<p>This option is only available if the option Keep the replica after the backup is selected.</p> <p>During ZDB sessions, Data Protector creates a new replica and leaves it on the disk array until the value specified for the option Number of replicas rotated is reached. After that, the oldest replica is deleted and a new one created.</p> <p>The number of standard snapshots or vsnaps is limited by the HPE 3PAR StoreServ Storage system. Data Protector does not limit the number of replicas rotated, but the session fails if the limit is exceeded.</p> <p>Default: 1.</p>
Track the replica for instant recovery	<p>This option is only available if the option Keep the replica after the backup is selected.</p> <p>Select this option to perform a ZDB-to-disk or ZDB-to-disk+tape session and leave the replica on the disk array to enable instant recovery. Specify also a value for the option Number of replicas rotated.</p> <p>If this option is not selected, you cannot perform instant recovery using the replica created or reused in this session.</p>

Replication mode

HPE 3PAR Local Copy	Select this option to configure a ZDB backup specification for HPE 3PAR
----------------------------	---

	<p>storage systems, which are not part of the remote copy group.</p> <p>If a volume that is part of the 3PAR Remote Copy group is selected for the backup, this volume will not be considered as part of the Remote Copy group, and backup continues to create the replica on the primary array.</p>
HPE 3PAR Remote Copy	<p>Select this option to configure a ZDB backup specification for HPE 3PAR storage systems, which are part of the remote copy group.</p> <p>If a volume that is not part of the 3PAR Remote Copy group is selected for backup, this volume will be considered as part of the Remote Copy group, and backup continues to create the replica on the primary array.</p>
Follow direction of replication	<p>This option is only available if HPE 3PAR Remote Copy option is selected.</p> <p>Select to follow the replication direction and create replicas on the disk array remote to the current source. After a failover, the replication direction is reversed and the replicas are created on the disk array that was originally a source HPE 3PAR storage system.</p>
Maintain replica location	<p>This option is only available if HPE 3PAR Remote Copy option is selected.</p> <p>Select to maintain replica location and create replicas on the disk array remote to primary array. After a failover, replicas will continue on the destination disk array that became the primary HPE 3PAR storage system during the failover.</p>

Application system options

Dismount the filesystems on the application system before replica generation	<p>Select this option to dismount the filesystems on the application system before replica creation and remount them afterwards. Additionally, when entire physical drives (on Windows systems) or</p>
---	--

	<p>entire disks or logical volumes (on UNIX systems) are selected as backup objects in a disk image backup specification, selecting this option will dismount and later remount all filesystems on these objects. If any of these filesystems cannot be dismounted, the backup session fails.</p> <p>If an integrated application (for example, Oracle Server) exclusively controls data I/O on each physical drive, disk, or logical volume that will be backed up, the dismount operation is not needed. In such a case, you can leave this option cleared.</p> <p>Default: not selected.</p>
<p>Stop/quiesce the application command line</p>	<p>If a command is specified in this option, it is invoked on the application system immediately before replica creation. An example is to stop applications not integrated with Data Protector.</p> <p>The command must reside on the application system in the default Data Protector administrative commands directory. Do not specify the path to the command in this option.</p> <p>If the command fails, the command specified in the option Restart the application command line is not invoked. Thus, you may need to implement a cleanup procedure in the command specified in Stop/quiesce the application command line. If the <code>omnirc</code> option <code>ZDB_ALWAYS_POST_SCRIPT</code> is set to 1, the command specified in the option Restart the application command line is always invoked.</p>
<p>Restart the application command line</p>	<p>If a command is specified in this option, it is invoked on the application system immediately after replica creation. An example is to resume operation of applications not integrated with Data Protector.</p> <p>The command must reside on the application system in the default Data Protector administrative commands directory. Do not specify the path to the command in this option.</p>

Backup system options

<p>Use the same mountpoints as on the application system</p>	<p>This option is not available if the application system is also the backup system (a single-host configuration).</p> <p>If this option is selected, the paths to mount points used for mounting the filesystems of the replica on the backup system are the same as paths to mount points where source volume filesystems were mounted on the application system.</p> <p>If the mount points are already in use, the session fails. For such circumstances, you must select the option Automatically dismount the filesystems at destination mountpoints in order for the session to succeed.</p>
---	--

	<p>Windows systems: The drive letters must be available, otherwise the session fails.</p> <p>Default: not selected.</p>
<p>Root of the mount path on the backup system</p>	<p>This option is only available if the option Use the same mountpoints as on the application system is not selected.</p> <p>Specifies the root directory under which the filesystems of the replica are mounted.</p> <p>Where exactly the filesystems are mounted depends on how you define the option Add directories to the mount path.</p> <div style="background-color: #f0f0f0; padding: 5px;"> <p>Note: For the SAP R/3 integration, the option is not applicable (the mount points created are always the same as on the application system).</p> </div> <p>Defaults:</p> <p>Windows systems: c:\mnt</p> <p>UNIX systems: /mnt</p>
<p>Add directories to the mount path</p>	<p>This option is only available if the option Use the same mountpoints as on the application system is not selected.</p> <p>This option enables control over the created mount points. It defines which subdirectories will be created in the directory defined with the Root of the mount path on the backup system option. When Session ID is used in path composition, this guarantees unique mount points.</p> <p>Example for Windows systems:</p> <p>Root directory: C:\mnt</p> <p>Application system: applsys.company.com</p> <p>Backup session ID: 2008-02-22-4</p> <p>Mount path on the application system: E:\disk1</p> <p>If Hostname is selected:</p> <p>C:\mnt\applsys.company.com\E\disk1</p> <p>If Hostname and session ID is selected:</p> <p>C:\mnt\applsys.company.com\2008-02-22-4\E\disk1</p> <p>If Session ID is selected:</p> <p>C:\mnt\2008-02-22-4\E\disk1</p> <p>If Session ID and hostname is selected:</p> <p>C:\mnt\2008-02-22-4\applsys.company.com\E\disk1</p>

	<p>NOTE:</p> <p>For the SAP R/3 integration, the option is not applicable (the mount points created are always the same as on the application system).</p> <p>Default: Hostname and session ID.</p>
<p>Automatically dismount the filesystems at destination mountpoints</p>	<p>If the mount points are in use (for example, volumes involved in the previous session may still be mounted) and this option is selected, Data Protector attempts to dismount the mounted filesystems.</p> <p>If the option is not selected and the mount points are in use, or if the option is selected and the dismount operation fails, the session fails.</p> <p>Default: not selected.</p>
<p>Leave the backup system enabled</p>	<p>This option is only available if the option Keep the replica after the backup is selected.</p> <p>If this option is selected, the filesystems remain mounted, the volume groups remain imported and active (UNIX systems), and the target volumes remain presented after the session. In this case, you can use the backup system for data warehousing purposes, but <i>not</i> for instant recovery. If the replica has to be reused later on (deleted, rotated out, or used for instant recovery), Data Protector automatically connects to the backup system, dismounts the filesystems, unrepresents the target volumes, and clears the related logical structures on the backup system. At that point in time, if the filesystems are not mounted to the current backup system, Data Protector cannot perform a proper cleanup, and aborts the operation or the instant recovery session.</p> <p>If this option is not selected, Data Protector dismounts filesystems, exports volume groups (UNIX systems), and unrepresents the target volumes on the backup system at the end of the ZDB session.</p>
<p>Enable the backup system in read/write mode</p>	<p>This option is applicable to and can only be changed for UNIX systems only. On Windows systems, filesystems cannot be mounted in the read-only mode.</p> <p>Select this option to enable write access to volume groups and filesystems on the backup system. For backup purposes, it is sufficient to activate the backup system volume groups and mount the filesystems in the read-only mode. For other tasks, the read/write mode may be needed.</p> <p>Note that when this option is selected, the replica is open to modifications while the backup system is online. Consequently, data restored from such a replica includes all potential modifications.</p> <p>Defaults:</p> <p>Windows systems: selected.</p>

	UNIX systems: not selected.
--	------------------------------------

Note: In a particular ZDB session, the mount point paths to which filesystems of the replica are mounted on the backup system correspond the mount point paths to which source volumes were mounted on the application system if at least one of the following conditions is met:

- The GUI option **Use the same mountpoints as on the application system** is selected.
- The `omnirc` option `ZDB_PRESERVE_MOUNTPOINTS` is set to 1.

If the option **Use the same mountpoints as on the application system** is not selected, and the `omnirc` option `ZDB_PRESERVE_MOUNTPOINTS` is set to 0, the mount point paths are determined by the GUI options **Root of the mount path on the backup system** and **Add directories to the mount path**, and the `omnirc` options `ZDB_MULTI_MOUNT` and `ZDB_MOUNT_PATH` are ignored.

Chapter 15: Restore

Instant recovery sessions that involve a HPE 3PAR StoreServ Storage system can be initiated natively using the HPE 3PAR StoreServ Storage integration, or through the Data Protector Microsoft Volume Shadow Copy Service integration using the 3PAR VSS Agent, provided that the corresponding zero downtime backup sessions were also initiated through this integration.

For information on replica handling during instant recovery, description of the instant recovery process, and storage system-specific instant recovery considerations, see the *HPE Data Protector Concepts Guide* and the *HPE Data Protector Help* index: “instant recovery: process overview”.

For additional storage system-specific instant recovery considerations and instructions for running instant recovery sessions using the Data Protector Microsoft Volume Shadow Copy Service integration, see the *HPE Data Protector Integration Guide for Microsoft Volume Shadow Copy Service*.

Instant recovery

Instant recovery restores data directly from a replica to source volumes, without involving a backup device. All data in the replica is restored, including filesystems or other objects which were not explicitly selected for backup. For instant recovery concepts, see the *HPE Data Protector Concepts Guide*.

You can perform instant recovery using:

- The Data Protector GUI
See ["Instant recovery using the GUI" on the next page](#).
- The Data Protector CLI
See ["Instant recovery using the CLI" on page 141](#).

The number of replicas available for instant recovery is limited by the value of the option **Number of replicas rotated**, which determines the size of the replica set. You can view these replicas in the GUI in the Instant Recovery context by expanding Restore Sessions. Replicas are identified by the backup specification name and the session ID. Other information, such as time when the replica was created, is also provided. Alternately, you can use the Data Protector command `omnidbzd` to list sessions. For more information, see the *HPE Data Protector Command Line Interface Reference* or the `omnidbzd` man page.

When instant recovery starts, Data Protector disables the application system. This includes dismounting filesystems and deactivating or exporting volume groups (UNIX). Before this is done, filesystems' and volume groups' status is checked, and only mounted filesystems are dismounted and active volume groups are deactivated or exported. At the end of the session, volume groups are reactivated and dismounted filesystems are mounted to the same mount points as were used during backup.

Limitations

- Instant recovery fails in the following situations:
 - The source volumes do not exist on the disk array any more.
 - The source volumes are not presented to the application system.
 - If the current configuration of the participating volumes (on Windows systems) or volume groups (on UNIX systems) is different from the volume/volume group configuration that existed at the time of the ZDB session and which was recorded in the SMISDB.
 - After instant recovery, restored filesystems are mounted to the same mount points or drive letters on the application system as they were at the backup time, but these mount points or drive letters have other filesystems mounted.
- While an instant recovery session is in progress, you cannot perform a zero downtime backup session that involves the source volumes to which the data is being restored.

For the HPE 3PAR StoreServ Storage instant recovery-related limitations and considerations, see the HPE Data Protector Product Announcements, Software Notes, and References and the *HPE Data Protector Concepts Guide*.

Instant recovery methods

With HPE 3PAR StoreServ Storage, instant recovery can be performed using the "copy-back" method, which copies replica data without retaining the source volumes.

With this instant recovery method, the source volumes are directly overwritten with data from the replica. 3PAR does not allow to continue before restore is completed. The restore process runs until finished or aborted. The source volumes are not retained and if the instant recovery session fails, the original application data residing on the source volumes is lost.

Instant recovery procedure

Prerequisites

- Target volumes used in an instant recovery session should not be presented to any system. You can make Data Protector automatically remove any disallowed target volume presentations by selecting the option **Force the removal of all replica presentations** in the GUI or by specifying the `omnir` option `-force_prp_replica` in the CLI.
- If a disk image backup with filesystems mounted on the selected disks was performed, manually dismount the filesystems on the disks to be restored before disk image instant recovery. If the option **Check the data configuration consistency** is cleared in the GUI or the `omnir` option `-check_config` is not specified in the CLI, the disks are dismounted automatically. In any case, re-mount the filesystems back after instant recovery.

Instant recovery using the GUI

Follow the steps:

1. In the Context List, select **Instant Recovery**.
2. In the Results Area, select the backup session (replica) from which you want to perform the recovery. This can be done by selecting:
 - Backup session ID and name (in the Scoping Pane, expand **Restore Sessions** and select a session from the list of ZDB-to-disk and ZDB-to-disk+tape sessions)
 - Backup object type (Filesystem, SAP R/3, ...) and backup session name and ID:
 - i. In the Scoping Pane, expand **Restore Objects**. Backed up object types are displayed.
 - ii. Expand the object type you want to restore. All available backup specification used in ZDB-to-disk or ZDB-to-disk+tape sessions for the selected object type are displayed.
 - iii. Expand the backup specification containing the replica set. Available sessions IDs (replicas) are displayed.

Selecting a session

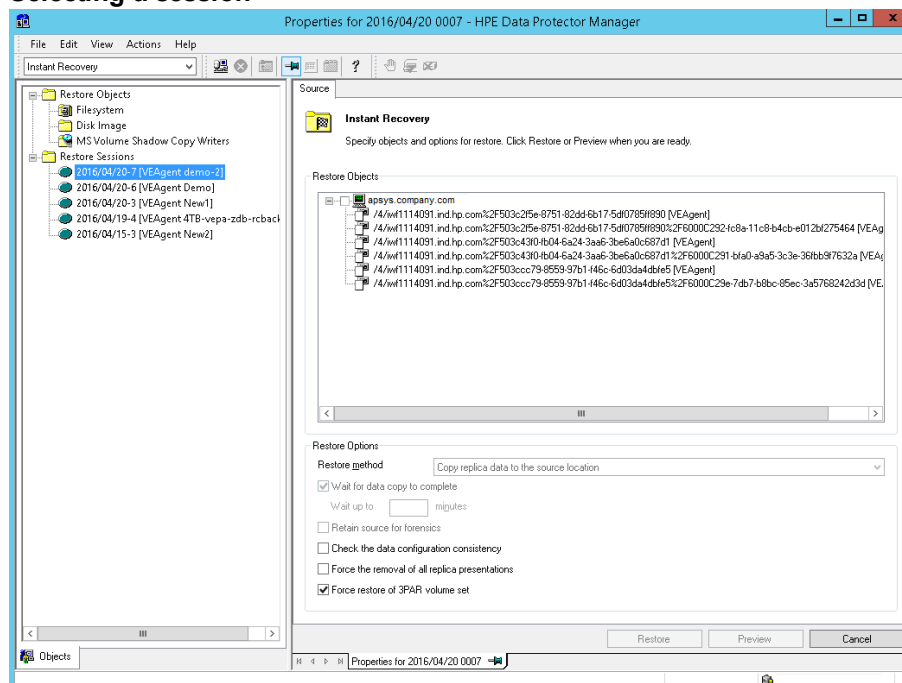

3. In the Scoping Pane, click the backup session (replica) you want to restore.
4. Check the selection box next to the application system to select the session for restore.
5. Specify other instant recovery options as desired. For information, see ["Selecting a session" above](#) and ["Instant recovery" on page 138](#), or press **F1**.
6. Click **Restore** to start the instant recovery session or **Preview** to start the instant recovery preview.

You cannot use the Data Protector GUI to perform instant recovery using backup data created in a ZDB-to-disk+tape session after the media used in the session has been exported or overwritten. In such circumstances, use the Data Protector CLI instead. Note that the backup media must not be exported or overwritten even after an object copy session.

Instant recovery using the CLI

1. List all available ZDB-to-disk or ZDB-to-disk+tape sessions (identified by the session ID):

```
omnidbzd --list --session --ir
```

From the output, select the backup session you want to restore.

2. Run the following command:

```
omnir -host ClientName -session SessionID -instant_restore [INSTANT_RECOVERY_OPTIONS]
```

where the meaning of the options is as follows:

ClientName Application system name.

SessionID Backup session ID

For *INSTANT_RECOVERY_OPTIONS*, see "[Instant recovery options](#)" below.

For details, see the *HPE Data Protector Command Line Interface Reference* or the omnidbzd and omnir man pages.

Instant recovery options

Instant recovery options

Data Protector GUI/CLI	Function
<p>Copy replica data to the source location / -copyback</p>	<p>This is the only available method with HPE 3PAR StoreServ Storage. It copies the replica data of the specified ZDB session to the original storage.</p> <p>Caution: If the instant recovery session fails, a data loss on the source volumes may occur.</p> <p>After the instant recovery session, the replica is not deleted from the replica set, and the information about it is not deleted from the SMISDB. Therefore, the replica is available for another instant recovery session until it is rotated out from the replica set or deleted manually.</p> <p>This instant recovery method takes about as much time as the replica creation did, but the storage redundancy level is preserved and the source volumes remain in their disk group.</p>
<p>Wait for the replica to complete / -wait_clonecopy</p>	<p>This option always enabled as HPE 3PAR StoreServ Storage does not allow creating presentations while copying data to the source location. Instant recovery session cannot continue before copy-back has finished and presentations cannot be created while restore is in progress.</p>
<p>Check the data</p>	<p>If this option is selected in the GUI or the -check_config option is specified</p>

Data Protector GUI/CLI	Function
<p>configuration consistency / -check_config -no_check_config</p>	<p>in the CLI, Data Protector performs a sanity check and a comparison of current volume group configuration of the volume groups participating in the instant recovery session and the volume group configuration information kept in the SMISDB after the corresponding zero downtime backup session. If the sanity check fails or the volume group configuration has changed since the zero downtime backup session, the instant recovery session aborts.</p> <p>MC/ServiceGuard clusters: When performing instant recovery to some other node than the one from which data was backed up, you must select this option in the GUI or specify the -check_config option in the CLI. In such circumstances, the current volume group configuration on the node to which data is to be restored differs from the volume group configuration kept in the SMISDB. Consequently, the SMISDB volume group configuration data is replaced by the current volume group configuration data on the node to which data is to be restored, and the instant recovery session succeeds.</p>
<p>Force the removal of all replica presentations / -force_prp_replica</p>	<p>If this option is selected in the GUI or specified in the CLI, and a target volume containing data to be restored is presented to a system, the HPE P6000 / HPE 3PAR SMI-S Agent removes such presentation. If the option is not selected in the GUI or not specified in the CLI, the instant recovery session fails in such circumstances.</p>
<p>Force restore of 3PAR volume set / -force_restore_volset</p>	<p>If this option is selected in the GUI or specified in the CLI, and a source volume (a member of the volume set) is exported to the application host using volume set, the HPE P6000 / HPE 3PAR SMI-S Agent removes all volumes that are part of the volume set presentation during instant recovery and adds them back after the restore completes. If the option is not selected in the GUI or not specified in the CLI, the instant recovery session fails in such circumstances.</p> <p>Note that if this option is selected during remove presentation, none of the volumes part of the volume set can be accessed.</p>

Instant Recovery for 3PAR Remote Copy environments

Introduction

This section describes the steps to be followed for executing the instant recovery procedure in 3PAR Remote Copy environments of the 3PAR storage systems using Data Protector.

Prerequisites

You should be familiar with the following:

- *HPE Data Protector Concepts Guide*
- HPE storage management appliance (SMA) documentation
- HPE 3PAR storage systems documentation
- Failover or cluster-failover documentation

Overview

Instant recovery restores data directly from a replica to source volumes, without involving a backup device.

For general information on instant recovery, see the *HPE Data Protector Zero Downtime Backup Concepts Guide* and *HPE Data Protector Zero Downtime Backup Administrator's Guide*.

The following sections outline different 3PAR remote copy configurations, and the steps you need to follow for a successful instant recovery.

Supported Remote Copy Configurations for Instant Recovery

The manual steps needed to prepare the environment for instant recovery differ depending on the 3PAR remote copy configurations.

Identifying the setup depends on the following environment information:

- The current site for the source side of any remote copy groups that include the source storage volumes
- Whether the remote copy or target storage volumes are on the same array as the source storage volumes (*primary*), or on the remote side of the DR group (*secondary*)

From this information, there are two possible configurations:

- Configuration I – HPE 3PAR remote copy replica is on the local side of the HPE remote copy group
- Configuration II – HPE 3PAR remote copy replica is on the remote side of the HPE remote copy group

Configuration I – local HPE 3PAR Remote Copy Replica

Replicas on the local site

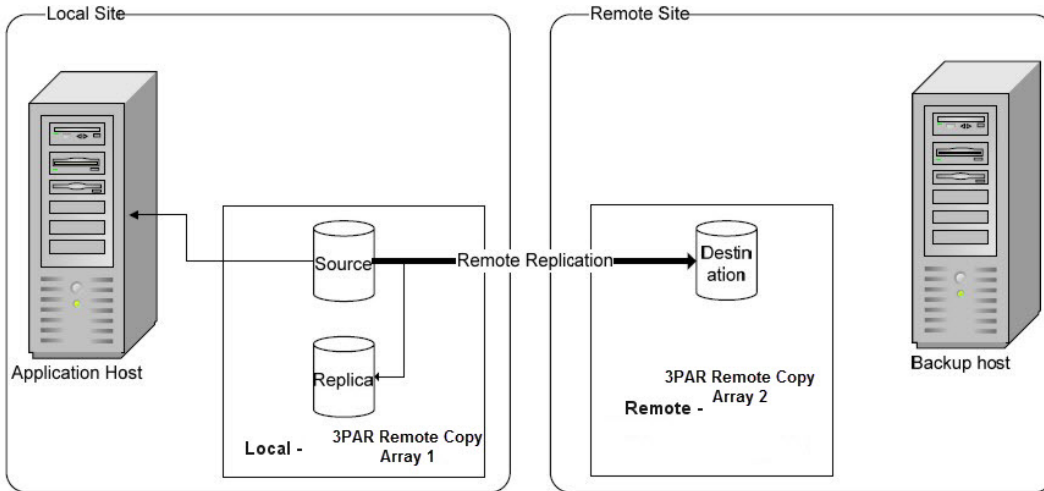

In this configuration, at the time of instant recovery, the source and replica storage volumes reside on the current local site.

Note: The source storage volume (“Source” in the diagram) acts as both the source of the replica storage volume and the source for the remotely replicated storage volume (“Destination” in the diagram).

Configuration II – remote HPE 3PAR Remote Copy Replica

Replicas on the remote site

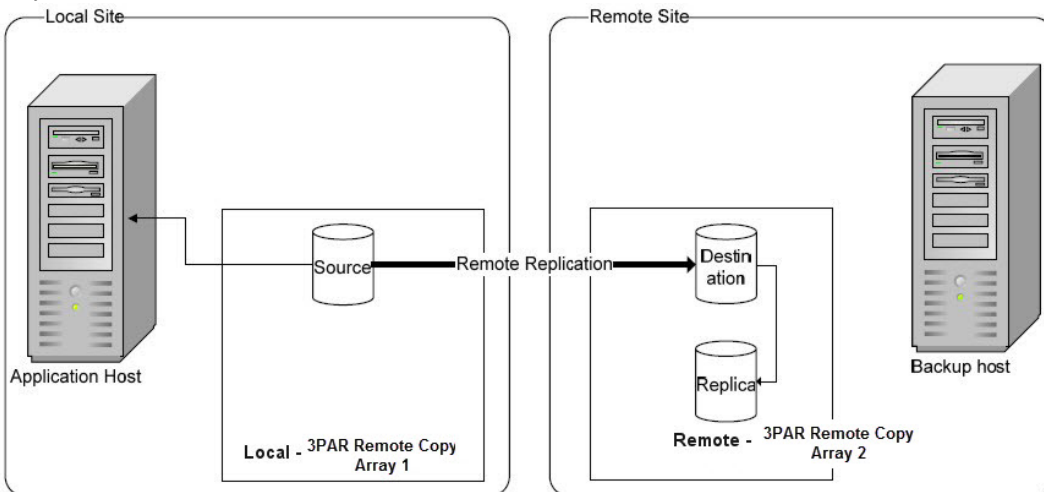

In this configuration, at the time of instant recovery, the ZDB environment has the source virtual disk residing on the local site. The remote replica (the replica of the source virtual disk replicated using 3PAR remote copy) and its local replica are both on the remote site.

Note: The storage volume marked “Destination” in the diagram is both the *destination* of the remote copy group and the *source* of the replica storage volume.

Instant recovery in HPE 3PAR Remote Copy environments

The steps for an instant recovery procedure is as follows:

1. Identifying the current configuration
2. Performing a remote copy group failover, if the replica is on the remote side
3. Modifying or removing the remote copy group
4. Performing instant recovery
5. Rebuilding the remote copy group, if the replica is on the remote side

The following flow chart summarizes this general process.

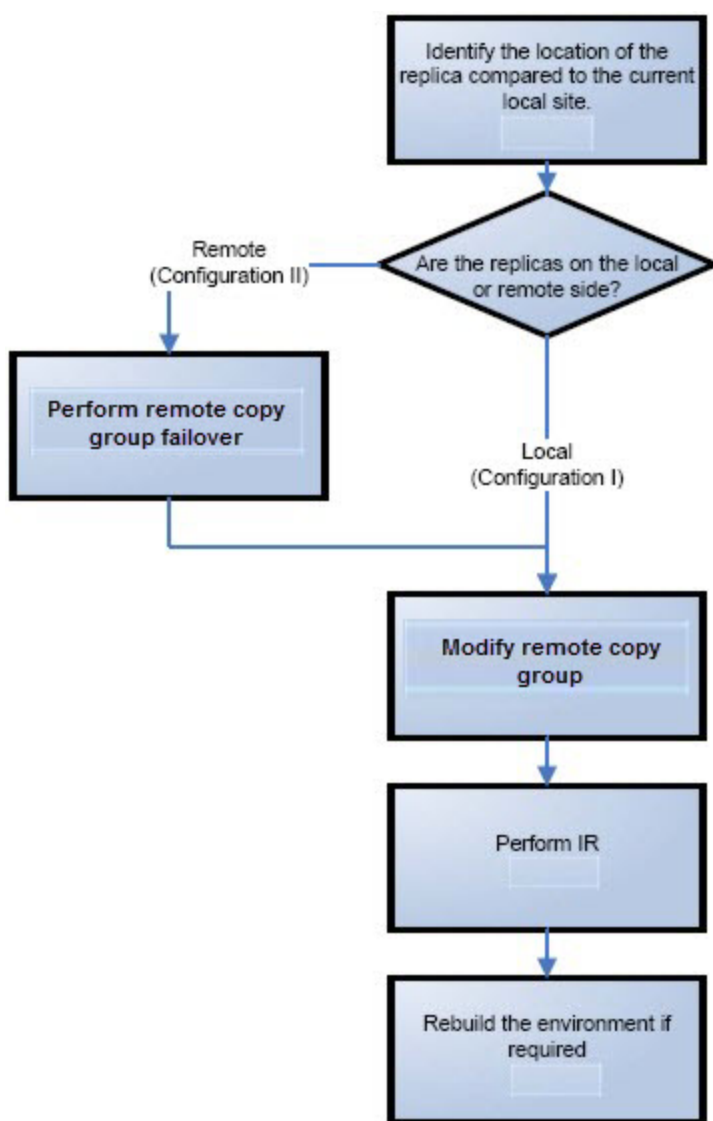

Identifying the current configuration

The following steps help identify the location of the source and target volumes:

1. Select the session for which instant recovery will be performed.

List the sessions available for instant recovery using the Data Protector GUI (the **Instant Recovery** context) or the Data Protector CLI (the `omnidbzd` command)

```
# omnidbzd --diskarray 3par -list -session -ir
```

```
Found 2 3PAR SMI-S session(s) in the internal database:
```

Session ID	IR	Type	Excluded	Backup Specification
2015/06/02-1	Yes	VSnap	No	DP-Dev-3par-backup
2015/06/02-2	Yes	VSnap	No	DP-Dev-3par-backup

```
#
```

2. Identify the source objects and the remote copy information.

Query the objects of the specific session using the `omnidbzd` command. The following example is for a session with ID `2015/06/02-2`.

```
#omnidbzd --diskarray 3par -show -session 2015/06/02-2
```

```
Info on session "2015/06/02 0002":
```

```
Target volume virtual disk name : DP-2015.06.02-2-XXE267X
Target volume virtual disk ID   : 5000-XXXX-YYYY-ZZZZ
Target volume virtual disk WWN  : 5000-XXXX-YYYY-ZZZZ
HPE Array Family name         : 3PAR
HPE Array Family ID           : 130XXXX
Target volume snapshot type    : VSnap
Source volume virtual disk ID   : 5000-XXXX-YYYY-ZZZZ
Session ID                     : 2015/06/02-2
Creation Date                   : Tue Jun 02 14:56:00 2015
IR flag                          : 1
Excluded                         : 0
Source disk version             : 0
Backup specification            : DP-Dev-3par-backup
Application System              : computer1.company.com
Backup System                   : computer2.company.com
```

```
#
```

From this output, you can find the following information:

- The target/replica virtual disk WWN, and the name:
 - *WWN:* 5000-XXXX-YYYY-ZZZZ,
 - *Name:* DP-2015.06.02-2-XXE267X
- The 3PAR array name and the WWN where the matched primary and secondary volumes

exist:

- *Name*: 3PAR
3. Use this information to locate the source storage volume and the 3PAR replica where it resides. You can also locate the target storage volume or the target virtual disk to verify that it still exists:
 - a. Connect to the 3PAR Management Console.
 - b. Navigate through the 3PAR Array, and get the virtual volume name from the Provisioning tab. Look for the virtual disk with a matching WWN.
 - c. The following information should be gathered from this panel:
 - Remote Copy status group name
 - Remote Copy group

The remote copy status is used to identify the configuration of the current environment

- If the remote copy status is “Primary”, the current environment is Configuration I. In this case, proceed to Step 3: Modifying or removing the Remote Copy group.
- If the remote copy status is “Secondary”, the current configuration is Configuration II. In this case, proceed to Step 2: Performing failover.

Note: Complex environments may include a mixture of Configuration I and Configuration II. In this scenario, remote copies exist that are both local and remote in relation to the source storage volumes. To handle this, perform the actions stated in Step 2: Performing Failover only to the remote copy groups with the “Secondary” status.

Performing failover

Use the information you have gathered regarding remote copy groups to perform failover as appropriate for the environment. Before taking any action, see the appropriate HPE 3PAR documentation for full details.

For more complex environments, including clusters or other high-availability solutions, see the appropriate documentation for that solution before performing any failover actions.

After performing the failover, proceed to modify or remove the remote copy group.

Modifying or removing the Remote Copy group

Note: Before taking any action, record the information relating to the remote copy groups. This includes such things as the virtual disks participating in the remote copy group, which the 3PAR storage systems are being replicated to, the mode of operation, and other specific details.

Modify the environment so that the source virtual disks no longer participate in a remote copy group.

When this is completed, proceed to step 4 to perform the instant recovery.

Performing instant recovery

Using the Data Protector GUI or CLI, perform instant recovery with the selected session. This should complete successfully with the appropriately reconfigured environment. For more information, see [Instant recovery procedure](#).

When this has been completed, optionally proceed to rebuilding the remote copy group.

Rebuilding the Remote Copy group

If the replica is on the remote side ([Configuration II](#)), return the new source virtual disks to the specific remote copy groups. Using the information you recorded in step 3 regarding the environment and specific remote copy groups, either rebuild or recreate the remote copy groups.

Note: Ensure that you use the newly-recovered storage volumes for this rebuild of the 3PAR remote copy groups. These storage volumes should have the same names and the WWNs as the storage volumes used previously. However, as these are different virtual disks, the UUIDs will be different from those used by the application system before for the virtual disks.

For more details, see the 3PAR user documentation. You may also need to perform additional steps to bring the environment to the same initial state, including failing over the 3PAR remote copy groups, to return operation to the correct 3PAR storage systems and application servers.

Chapter 16: Troubleshooting

Before you begin

This chapter lists general checks and verifications that you may need to perform when you encounter problems with the HPE 3PAR StoreServ Storage integration. For general Data Protector troubleshooting information, see the *HPE Data Protector Troubleshooting Guide*. For VSS-specific Data Protector troubleshooting information, see the *HPE Data Protector Integration Guide for Microsoft Volume Shadow Copy Service*.

- Ensure that the latest official Data Protector patches are installed. For information on how to verify this, see the *HPE Data Protector Help* index: “patches”.
- For general Data Protector and integration-specific limitations, as well as recognized issues and workarounds, see the HPE Data Protector Product Announcements, Software Notes, and References.
- For an up-to-date list of supported versions, platforms, and other information, see <https://softwaresupport.hpe.com/>.

Checks and verifications

- On the application and backup systems, examine system errors logged into the `debug.log` file residing in the default Data Protector log files directory.

Backup problems

Problem

You cannot select the HPE 3PAR sub type in the Data Protector user interface when creating a ZDB backup specification

Action

Check that the HPE P6000 / HPE 3PAR SMI-S Agent integration module is installed on the application system and the backup system. To do that, open the `cell_info` file located on the Cell Manager in the following directory:

Windows systems: `Data_Protector_program_data\Config\server\cell\cell_info`

UNIX systems: `/etc/opt/omni/server/cell/cell_info`

File contents should look similar to the following:

```
-host "sap002.company.com" -os "HPs800 hp-ux-11.00" -cc A.09.00 -da  
A.09.00 -ma A.09.00 -SMISA A.09.00
```

Problem

The HPE P6000 / HPE 3PAR SMI-S Agent fails to connect to the Cell Manager and retrieve configuration data

[Major]

Cannot connect to the Cell Server. (Insufficient permissions. Access denied.)

The HPE P6000 / HPE 3PAR SMI-S Agent is always started as an administrator's process on the application and backup systems. Therefore, the user who starts it must be the member of **admin** or **operator** user groups.

Action

Using the GUI, check if the user is a member of **admin** or **operator** user groups. If not, add the user to one of these groups. In addition, ensure that administrators from both the application and backup systems belong to Data Protector **admin** or **operator**.

Problem

On an HP-UX system, the HPE P6000 / HPE 3PAR SMI-S Agent fails to communicate with the array provider using SSL

[Warning]

The SSL connection to the SMI-S provider has failed.

The error description returned is:

SSL Exception: Random seed file required

On HP-UX systems, Pegasus libraries require the random number generator pseudo device for its SSL-based communication with the SMI-S provider. If the pseudo device is not present, the warning appears.

Action

1. Install the pseudo device in `/dev/random` on the HP-UX backup system.
2. Re-run the session.

Problem

No HPE SMI-S CIMOM login entries are configured within SMISDB

Action

Add an HPE SMI-S CIMOM login information to SMISDB:

```
omnidbzd --diskarray 3PAR --ompasswd --add ClientName [--ssl] [--port PortNumber]  
[--user Username] [--passwd Password]
```

Problem

On a UNIX system, ZDB sessions stop responding for a long time during the resolving of the backup objects on the application system

When resolving the backup objects on the application system, Data Protector sends SCSI inquiries to identify the vendor-specific details of the virtual disk to be replicated. If this virtual disk belongs to a DR group that is in the “failsafe-locked” mode, SCSI inquiries do not return at all. As a result, the session stops responding.

Action

1. Abort the session and stop the ZDB agent processes that stopped responding on the application system.
2. Identify the root cause for the “failsafe-locked” mode of the DR group and fix it by bringing the DR group back into normal operational mode.

Problem

On the application system, dismounting a filesystem fails

Action

Ensure that no other processes use the filesystem to be dismounted. If `Stop/quiesce` the application command line was specified, check that it stops all processes using the filesystem.

Problem

On a Windows system, replica cannot be mounted to the target location on the backup system

```
[Major]
Filesystem \\.\Volume{9640da9a-6f36-11d7-bd7a-000347add7ba} could not
be mounted to C:\mnt.
([145] The directory is not empty.).
```

When a backup with nested mountpoint objects is run, replica cannot be mounted to the target mountpoint location on the backup system if cleaning of the target mountpoint location fails.

Action

On the backup system, manually empty the directory where filesystems are to be mounted or select the backup option **Automatically dismount the filesystems at destination mountpoints**. If you choose manual action, and leave the default root mount path `c:\mnt` in the ZDB backup specification, you should empty the `mnt` directory.

Problem

Data Protector fails to delete a replica from the replica set in a cluster environment

A ZDB session reports the following major error and message:

```
[Major]
Resolving of storage volume TargetVolumeID has failed.
...[Normal]
Some disks are still in use. They will be moved in purge bucket.
```

This error may occur in a cluster environment with the backup system which is a cluster virtual server. In such circumstances, after a failover, new backup sessions cannot rotate out the replicas on the

active node because the presentations match the passive node. The replicas to be removed are marked with the purge flag in the SMISDB, and you are advised to delete such replicas.

Action

To delete the replicas with the purge flag from the disk array and the SMISDB, perform one of the following actions:

- Manually delete all storage volumes that are marked for purging by running:
`omnidbzd --diskarray 3PAR --purge [--force] --host ClientName`
where *ClientName* is the name of the node on which you want to perform the purge operation.
Use the `-force` option to remove the volumes marked for purging even if they are presented to a system.
- Perform manual failover and run another ZDB session. The session will delete all the volumes marked for purging on the new active node.

Problem

On an HP-UX system, backup session freezes during either preparation or resuming of the backup system

One of the following messages appears:

```
[Normal]  
Starting drive discovery routine.
```

```
[Normal]  
Resuming the backup system.
```

During the backup system preparation, Data Protector adds new devices to the Secure Path control and runs device scanning. When resuming the backup system, Data Protector removes devices from the Secure Path control and runs device scanning.

If some other process runs Secure Path commands or device scanning at the same time (during either preparation or resumption), the session may freeze. To identify this problem, run the `ps -ef` command several times on the backup system and check if any `ioscan` or `spmgr` processes persist in the output.

Action

Abort the backup session and stop the hanging `ioscan` and `spmgr` processes.

If processes cannot be stopped, restart the backup system and clean it up manually:

1. On the backup system, run `spmgr display` to display the target volumes (created in the failed session) left under the Secure Path control.
2. Remove such target volumes from the Secure Path control using `spmgr delete`.
3. Run `spmgr update`, and then follow reported instructions to make changes persistent across system restart processes.
4. Using the HPE 3PAR Management Console, delete all presentations attached to removed target volumes.

Problem

On Linux systems, a backup to LVM volumes fails.

The option **Leave the backup system enabled** was selected for the backup. The following error message is displayed:

```
[Major] From: SMISA@company.com "SMISA" Time: 12/06/2013 1:06:26 PM
```

It is possible that duplicated LVM UUIDs and/or names will appear on the backup system.

Session will abort.

Action

Set the `lvm.conf` file parameters properly. For more information, see the ["Prerequisites" on page 119](#).

Problem

The 3PAR ZDB remote copy periodic backup fails.

The 3PAR remote copy periodic backup of some of the storage volumes fails with the following error message:

```
[Major] From: SMISA@hostname "SMISA" Time: Date Time
```

Skipping the backup of storage volume as Remote Copy group sync operation in progress.

Group name : *3PAR remote-copy-group name*

Storage volume : *3PAR remote-copy-group storage volume name*

Action

- If a manual sync operation is still in progress when the backup is started, then wait for the manual sync operation to complete, and then start the ZDB backup.
- If the sync operation initiated by Data Protector does not complete in the specified time period, increase the wait-time for the sync operation in the `ZDB_WAIT_FOR_PERIODIC_SYNC_TO_COMPLETE` and the `ZDB_WAIT_FOR_PERIODIC_SYNC_RETRY_COUNT` variables.

Problem

The 3PAR ZDB remote copy backup fails.

The 3PAR remote copy backup of some of the storage volumes fails with the following error message:

```
[Major] From: SMISA@hostname "SMISA" Time: Date Time>
```

Skipping the backup of storage volume as remote copy group is in stopped state.

Group name : *3PAR remote-copy-group name*

Storage volume : *3PAR remote-copy-group storage volume name*

Action

The 3PAR remote copy group is in the *Stopped* state. *Start* the remote copy group and run the backup.

Restore problems

Problem

On the Unix or Linux operating system, after the successful ZDB raw disk image restore, the data is not visible.

Action

Re-mount the volumes, and check again for the data.

Example: `umount/<disk mountpoint name>` and `mount/<disk mountpoint name>`

Instant recovery problems

Problem

Instant recovery fails

The problem may occur if the option **Force the removal of all replica presentations** is not selected and a target volume from the selected replica is presented to some system other than the backup system or the target volume cannot be dismounted.

Action

Select the option **Force the removal of all replica presentations** and restart the instant recovery session.

Problem

On a Windows system, instant recovery to a different cluster node fails

```
[Major]
Filesystem volume_name could not be dismounted from drive_letter
([2] The system cannot find the file specified.).
[Critical]
Failed to disable the application system.
[Critical]
Failed to resolve objects for Instant Recovery.
```

On Windows systems, the automatic preparation of the application system cannot match clustered volumes from one cluster node to the volumes on another node.

Action

Disable the automatic preparation of the application system:

1. On the application system, enable the `ZDB_IR_MANUAL_AS_PREPARATION` options (see ["Appendix" on page 228](#)) and manually dismount the volumes to be restored.
2. Start instant recovery.
3. After instant recovery, manually mount restored volumes.

Problem

The 3PAR ZDB remote copy group instant recovery fails

3PAR ZDB remote copy group instant recovery fails with the following error message:

```
[Minor] From: SMISA@hostname "SMISA" Time: Date Time
```

A SMI-S call to the array did not behave as expected.

Failed volume: DP-201X.XX.01-1-0XXXCDXXX

Returned message: Error calling provider to present volume 5XXX2ACXXXXXXXXBX:
Invalid parameter for promote snapshot volume: RW parent (3PAR remote copy group
storage volume name) is involved in a remote copy group

Action

Remove the storage volume that is part of the 3PAR remote copy group, and start the instant recovery.

Problem

The 3PAR ZDB local instant recovery fails

The 3PAR ZDB local instant recovery fails with the following error message:

```
[Minor] From: SMISA@hostname "SMISA" Time: Date Time
```

A SMI-S call to the array did not behave as expected.

Failed volume: DP-201X.XX.01-1-0XXXCDXXX

Returned message: Error calling provider to present volume 5XXX2ACXXXXXXXXBX:
Invalid parameter for promote snapshot volume: RW parent (3PAR remote copy group
storage volume name) is involved in a remote copy group

Action

Remove the storage volume that is part of the 3PAR remote copy group, and start the local 3PAR ZDB instant recovery.

Part 5: EMC Symmetrix

This part describes how to configure the Data Protector EMC Symmetrix integration, how to perform zero downtime backup and instant recovery using the EMC Symmetrix integration, and how to resolve the integration-specific Data Protector problems.

Chapter 17: Configuration

Introduction

This chapter describes the configuration of the Data Protector EMC Symmetrix (EMC) integration. It also provides information on the EMC Symmetrix database file and Data Protector EMC log file.

Prerequisites

- Install:

EMC licenses and components:

- EMC Solution Enabler
- EMC Symmetrix TimeFinder or EMC Symmetrix Remote Data Facility (SRDF) microcode and license.

Data Protector licenses and components:

- Appropriate zero downtime backup extension and instant recovery extension licenses-to-use (LTU).
- EMC Symmetrix Agent.

For installation instructions, see the *HPE Data Protector Installation Guide*.

- You should be familiar with:
 - EMC command-line interface
 - Logical Volume Manager concepts
- Make sure the `omnicrc` variables on both the application and backup hosts are set to:
`LD_LIBRARY_PATH=/usr/lib/hpux64`
`SHLIB_PATH=/usr/lib/hpux64`
`DYNAMIC_PATH=/usr/lib/hpux64`
`LIBPATH=/usr/lib/hpux64`
- Make sure the same operating system (and its version) is installed on the application and backup systems.
- If the application system and the backup system reside in a Data Protector cell with secured clients, ensure that access between both systems is allowed in both directions.
- Connect EMC to the application and backup systems.

See the HPE Data Protector Product Announcements, Software Notes, and References for:

- General Data Protector and integration-specific limitations
- Supported platforms and integrations
- Supported backup and connectivity topologies

For information on supported configurations, see the *HPE Data Protector Concepts Guide*.

EMC Symmetrix database file and Data Protector EMC log file

EMC Symmetrix database file

EMC Symmetrix database file contains the physical configuration information of SCSI parameters that define your storage complex. It is located in:

Windows systems: `symapi_home\db\symapi_db.bin`

HP-UX systems: `/var/symapi/db/symapi_db.bin`

Data Protector EMC log file

EMC log file keeps information about objects, devices, and device groups. It is located in:

Windows systems: `Data_Protector_home\Config\client\tmp\emc`

HP-UX systems: `/var/opt/omni/tmp/emc`

on the application and backup systems. Log files are named as `R1_session_name.log` or `R2_session_name.log`, where `session_name` is composed of the sessionID, the forward slashes "/" replaced with dashes "-." For example:

`R1_2013-09-13-3.log`

`R2_2013-09-13-3.log`

The log contains:

- Resolved EMC configuration (mapping to EMC devices).
- Created and deleted device groups, and the devices added to device groups.
- Operations on device groups (splitting links, incremental establish, incremental restore, ...).
- Status of backup and restore objects.

Check both log files if you encounter any problems. The logs can also be useful if you leave the links split after backup/restore.

Configuring the integration

Before you start with the configuration, make sure the prerequisites listed in "[Configuring the integration](#)" [above](#) are fulfilled. In addition, do the following:

Symmetrix Remote Data Facility (SRDF) configurations: Connect the application system to Application (R1) Symmetrix, and the backup system - to Backup (R2) Symmetrix.

Main Source (R1) Devices must be connected to the application system and have paired disks assigned. Paired Target (R2) Devices in the remote disk array must be connected to the backup system.

TimeFinder configurations: Connect the application and backup systems to the same disk array.

Standard Devices must be connected to the application system and have paired disks assigned. BCV Devices must be connected to the backup system.

Combined SRDF+TimeFinder configurations: Connect the application system to Application (R1) Symmetrix, and the backup system - to Backup (R2) Symmetrix.

Main Source (R1) Devices must be paired to Target (R2) Devices in Backup (R2) Symmetrix. Backup (R2) Symmetrix Target (R2) Devices also function as TimeFinder Standard Devices. They must be paired to BCV (R2) Devices.

It is recommended that only TimeFinder BCV (R2) Devices be connected to the backup system. If SRDF Target (R2) Devices are connected as well, `/etc/lvmtab` may get lost in this configuration. To ensure the configuration is correct, re-create volume groups using `vgscan`, and delete potentially added `pvlinks` to SRDF Target (R2) Devices using `vgreduce`.

To configure the integration:

- Create the Data Protector EMC database file. See "[Creating Data Protector EMC database file](#)" below.
- If needed, rebuild the EMC Symmetrix database file. See "[Rebuilding EMC Symmetrix database file](#)" below.

Creating Data Protector EMC database file

Data Protector EMC database file, used to store configuration information, is the same as the EMC Symmetrix database file. Create this file:

- Prior to starting Data Protector backups
- Each time your disk configuration changes

Alternately, you can set the `Run discovery of Symmetrix environment` option in the backup specification. However, this operation may be time-consuming because it checks disk configuration through low-level SCSI commands.

To create the Data Protector EMC database file, execute:

Windows systems: `Data_Protector_home\bin\syms -init`

HP-UX systems: `/opt/omni/lbin/syms -init`

This command creates the `Data Protector\Config\Client\EMC\syms.bin` (Windows) or `/var/opt/omni/emc/syms.bin` (HP-UX) Data Protector EMC database file on both the application and backup systems.

Rebuilding EMC Symmetrix database file

Rebuild the EMC Symmetrix database file with the current information about physical devices connected through SCSI buses to your system if:

- Your configuration changes
- You run the first command-line session

To scan the hardware and rebuild the database, execute:

```
symscfg discover
```

This command scans all SCSI buses on the system (not only those connected to EMC arrays).

To display the contents of the EMC Symmetrix database file, execute:

- `syminq -sym` (displays all EMC devices).
- `symbcv list dev` (lists all BCV devices configured on EMC).
- `symrdf list` (lists all RDF disk devices known to the system).

See "[EMC Symmetrix—obtaining disk configuration data](#)" on page 264 for more information.

Automatic configuration of backup system

When you start a ZDB session, Data Protector performs necessary configuration steps, such as configuring volume groups and filesystems on the backup system. Based on the volume group, filesystem, and mount point configuration on the application system, Data Protector creates the same volume group and filesystem structure on the backup system and mounts these filesystems during ZDB sessions.

For more information on the mountpoint creation, see the *HPE Data Protector Concepts Guide*.

Chapter 18: Backup

Introduction

This chapter describes configuring a filesystem or disk image ZDB using the Data Protector GUI.

You should be familiar with the EMC concepts and procedures and basic Data Protector ZDB functionality. See the EMC-related documentation and the *HPE Data Protector Concepts Guide*.

ZDB types

The only supported ZDB type is ZDB to tape.

With ZDB to tape, mirrors are created, and data from the replica is moved to backup media according to the tape backup type you have selected (Full, Incr, Incr1-9).

If the option **Re-establish links after backup** is not selected, the replica remains on a disk array until reused in the next backup session using the same EMC device pairs.

If the option **Re-establish links after backup** is selected, the replica is synchronized with the original after backup.

See the *HPE Data Protector Concepts Guide* for more information on ZDB-to-tape process.

Backup concepts

EMC backup consists of two phases:

1. Application system data gets synchronized to the backup system.
During this phase, the synchronization is performed on the level of participating volume groups (HP-UX) or disks (Windows). Therefore, if multiple filesystems/disk images are configured in the same volume group or on the same disk, the *whole* volume group or disk (all filesystems or disk images in this volume group or on disk) is synchronized to the backup system regardless of the objects selected for backup.
2. Synchronized backup system data is backed up to a backup device.
During this phase, only the objects selected for backup are backed up.

Such a concept enables the restore of selected objects (filesystems or disk images) for a split mirror restore and for a restore from backup media on LAN (filesystems, disk images or application objects).

With a split mirror restore, the links from the application to the backup system are synchronized before the restore, thus enabling the restore of the selected objects by establishing the current state of the application system data on the backup system, and then restoring the selected objects to the backup system, and finally resynchronizing the backup system to the application system.

Backup in LVM mirroring configurations

Consider the following:

- Only the physical volumes that contain the logical volumes selected for backup will be considered for replication.

Example

- A Volume Group (VG01) is made up of two physical volumes (PV1 and PV2)
- VG01 has two logical volumes (lvo11 and lvo12)
- The lvo11 has its logical extents on PV1, and lvo12 - on PV2
- A backup object belonging to lvo11 is selected in the backup specification

PV1 will be selected for replication.

Creating backup specifications

Before you begin, consider all limitations regarding the EMC integration. For more information, see the HPE Data Protector Product Announcements, Software Notes, and References and the *HPE Data Protector Concepts Guide*.

1. In the Context List, select **Backup**.
2. In the Scoping Pane, expand **Backup** and **Backup Specifications**. Right-click **Filesystem**, and click **Add Backup**.

The Create New Backup dialog box appears.

In the Filesystem pane, select the **Blank Filesystem Backup** template or some other template which you might have created. For information on templates, see the *HPE Data Protector Help* index: "backup templates".

Select **Split mirror backup** as **Backup type** and **EMC Symmetrix** as **Sub type**. See the *HPE Data Protector Help* for options' descriptions. Click **OK**.

3. Under Client systems, select **Application system** and **Backup system**. Also, specify the desired EMC configuration - TimeFinder, SRDF, or Combined (SRDF + TimeFinder).

See "[Backup options](#)" on page 164 for information on options.

In EMC GeoSpan for Microsoft Cluster Service environments, select the backup system for the active node and specify the TimeFinder configuration.

After a failover, select the backup system for the currently active node and save the backup specification.

Click **Next**.

4. **Filesystem backup**: Expand the application system and select the objects to be backed up. Note that all drive letters or mount points that reside on the system are displayed. You must select only objects that reside on the disk array, otherwise the backup session fails.

Click **Next**.

Disk image backup: Click **Next**.

5. Select devices. Click **Properties** to set the device concurrency, media pool, and preallocation policy. For more information on these options, click **Help**.

To create additional copies (mirrors) of backup, specify the number of mirrors by clicking **Add mirror** or **Remove mirror**. Select separate devices for each mirror backup.

For information on object mirroring, see the *HPE Data Protector Help* index: "object mirroring".

Click **Next**.

6. Under Backup Specification Options, click **Advanced** and then the **EMC Symmetrix** tab to open the EMC backup options pane.

Here, you can modify all options, except **Application system** and **Backup system**, as shown in "Backup options " below. See also "Backup options" on the next page.

For information on Filesystem Options, press **F1**.

Backup options

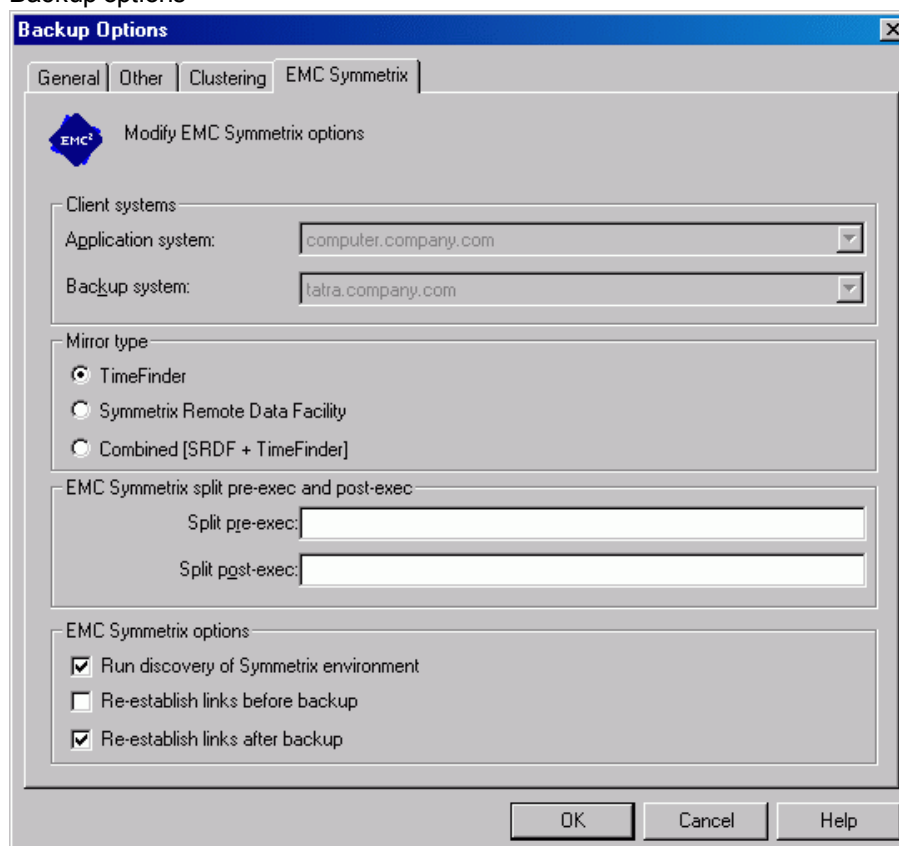

7. Following the wizard, open the scheduler (for information, press **F1** or see "Appendix" on page 228), and then the backup summary.

8. **Filesystem backup:** Click **Next**.

Disk image backup:

- a. Click **Manual add** to add disk image objects.
- b. Select **Disk image object** and click **Next**.
- c. Select the client and click **Next**.
- d. Specify General Object Options and Advanced Object Options. For information on these options, press **F1**.
- e. In the Disk Image Object Options window, specify disk image sections.

HP-UX systems:

Specify a disk image section:

`/dev/rdisk/filename`, for example: `/dev/rdisk/c2t0d0`

Or

`/dev/rdisk/disk<number>`, for example: `/dev/rdisk/disk395`

Specify a raw logical volume section:

`/dev/vgnumber/r1volnumber`, for example: `/dev/vg01/r1vol1`

Windows systems:

Use the following format:

`\\.\PHYSICALDRIVE#`

Where # is the current number of the disk to be backed up.

For information on finding current disk numbers (physical drive numbers), see the *HPE Data Protector Help* index: "disk image backups".

- f. Click **Finish** and **Next**.
- 9. Save your backup specification. For information on starting and scheduling backup sessions, see ["Appendix" on page 228](#).

Note: Backup preview is not supported.

Backup options

The following tables describe EMC backup options. See also ["Appendix" on page 228](#).

EMC backup options

Data Protector GUI	Function
Application system	The system on which the application runs. In cluster environments, specify the virtual server hostname (rather than the physical node hostname).
Backup system	The system to which the data will be backed up. In cluster environments, specify the virtual server hostname (rather than the physical node hostname). In EMC GeoSpan for MSCS environments, select the backup system for the active node. After a failover, select the backup system for the currently active node and save the backup specification.
Mirror type	EMC configuration: TimeFinder, Symmetrix Remote Data Facility, or Combined (SRDF + TimeFinder). In EMC GeoSpan for MSCS environments, specify the TimeFinder configuration.

Data Protector GUI	Function
Split pre-exec	<p>Create the optional <code>Split pre-exec</code> command in default Data Protector administrative commands directory on the application system. This command is executed on the application system before the split and is mainly used to stop applications not integrated with Data Protector.</p> <p>If <code>Split pre-exec</code> fails, <code>Split post-exec</code> is also not executed. Therefore, you need to implement a cleanup procedure in <code>Split pre-exec</code>.</p> <p>If the <code>ZDB_ALWAYS_POST_SCRIPT omnirc</code> option is set to 1, <code>Split post-exec</code> is always executed if set (default is 0). See "Appendix on page 228" for more information.</p> <p>Backup session is not aborted if the command set by <code>Split pre-exec</code> is not executed.</p>
Split post-exec	<p>Create the optional <code>Split post-exec</code> command in default Data Protector administrative commands directory on the application system. This command is executed on the application system after split and is mainly used to restart applications not integrated with Data Protector.</p>
Run discovery of Symmetrix environment	<p>Builds/re-builds the Data Protector EMC database on both the application and backup systems. See "Configuration on page 157" for more information.</p> <p>Default: selected.</p>
Re-establish links before backup	<p>Synchronizes disks before backup to maintain data integrity (may be necessary if you disabled Re-establish links after backup or used EMC commands that left the links split).</p> <p>Default: not selected.</p>
Re-establish links after backup	<p>Re-establishes links between the application and mirrored devices after backup. If this option is disabled, the links remain split after backup (in this case, you can use the mirrored devices on the backup system).</p> <p>Default: selected.</p>

The chart and table below provide detailed backup flow according to the backup options selected.

Filesystem split mirror backup flow

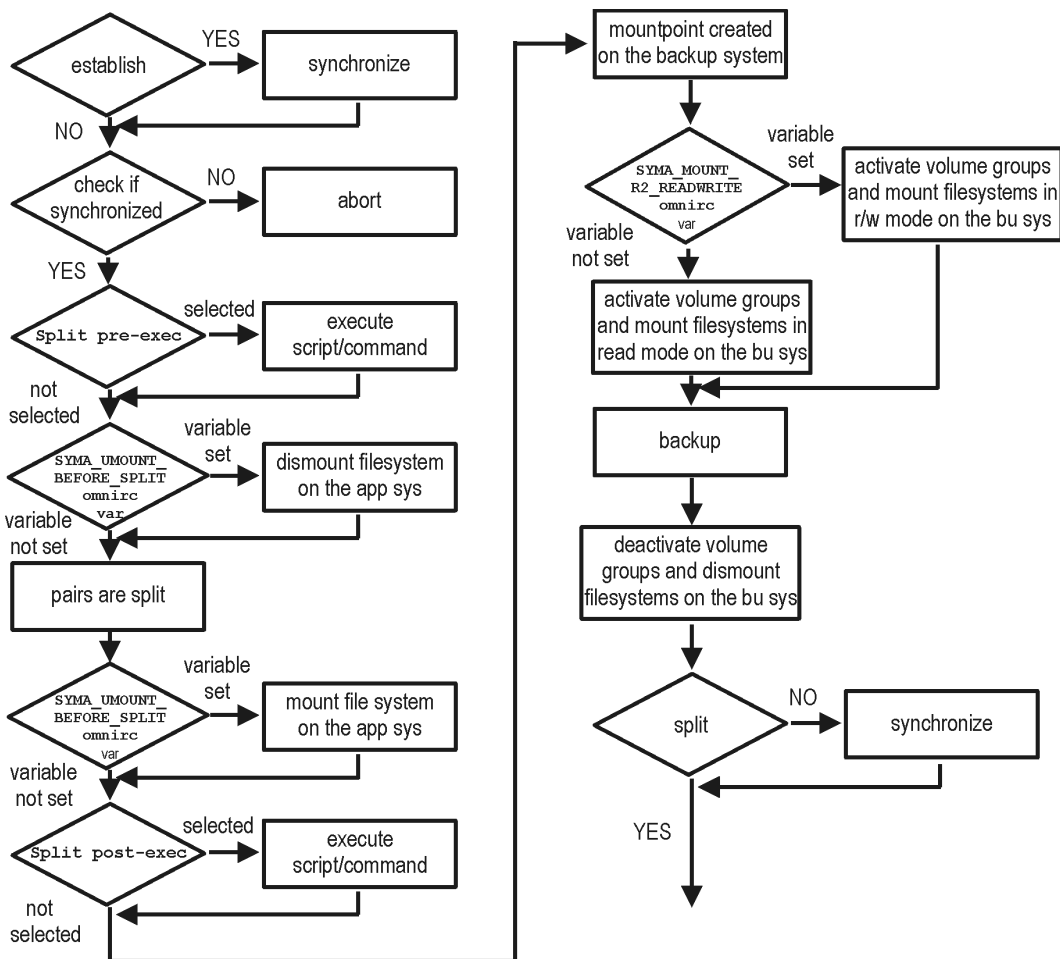

The “establish” and “split” checks depend on the following EMC backup options:

The Re-establish links after backup option is selected	split = YES
The Re-establish links before backup option is selected	establish = YES
The Re-establish links after backup option is not selected	split = NO
The Re-establish links before backup option is not selected	establish = NO

Backup disk usage

If mirrored devices are not re-established after backup, they still contain the last version of backed up data. You can use these mirrored devices to quickly restore or view your data.

Note: Data can only be restored using EMC device mirroring facilities.

To view this data, enable mirrored devices by activating volume groups (HP-UX) and mounting filesystems. The log file containing information about volume groups and filesystems is located in:

Windows systems: `Data_Protector_home\Config\client\tmp\emc\R2_session_name.log`

HP-UX systems: `/var/opt/omni/tmp/emc/R2_session_name.log`

where `session_name` is composed of the sessionID, forward slashes "/" replaced with dashes "-".

Testing backed up data

To test your backed up data:

1. Restore the data to the backup system or use mirrored devices not re-established after backup. Meanwhile, your applications run uninterrupted on the application system.
2. Test data integrity.

To restore to the backup system, follow the steps described in ["Split mirror restore procedure" on page 170](#) and set EMC split mirror restore options as explained in ["EMC test restore options" below](#).

EMC test options

Note: For testing, set the omnirc options SYMA_UMOUNT_BEFORE_SPLIT to 0 (default), and SYMA_MOUNT_R2_READWRITE to 1. For details, see ["Appendix" on page 228](#).

EMC test restore options

Data Protector GUI	Function
EMC Symmetrix mode	EMC configuration for test backup: TimeFinder, SRDF, or Combined (SRDF+TimeFinder). In EMC GeoSpan for MSCS environments, specify the TimeFinder configuration.
Application system	The system on which the application runs. In cluster environments, specify the virtual server hostname (rather than the physical node hostname).
Backup system	The system to which your data will be restored. In cluster environments, specify the virtual server hostname (rather than the physical node hostname). In EMC GeoSpan for MSCS environments, select the backup system for the active node. After a failover, select the backup system for the currently active node and save the backup specification.
Run discovery of the Symmetrix environment	Clear this option.

Data Protector GUI	Function
Re-establish links before restore	Either select or clear this option.
Disable disks on application client before split	Clear this option upon testing your backup (disks on the application system <i>must not</i> be disabled). Restore links after restore is also cleared, so applications on the application system run uninterrupted. Do not move restored data to the application system for test purposes. This can cause integrity problems.
Restore links after restore	Clear this option, leaving the links split. You can then check the integrity of restored data on the backup system.

For more information about options, see ["Split mirror restore options" on page 171](#).

Checking your restored data

If `Restore links after restore` is disabled, mirrored devices contain the restored version of data. To view this data, enable mirrored devices and mount filesystems.

Manually re-establish links using the appropriate EMC CLI command (`symrddf` or `symmir`), or enable the option `Re-establish links before backup/Re-establish links before restore` for the next backup/restore.

Caution: Do not restore data to the application system for test purposes. Otherwise, you will lose all data written to mirrored devices on the application system.

Chapter 19: Restore

Introduction

This chapter describes configuring and running a filesystem or disk image restore of the data backed up using the EMC integration. The sections describe restore procedures using the Data Protector GUI.

Available restore types are:

- Restore from backup media on LAN (standard restore). See ["Standard restore" below](#).
- Split mirror restore. See ["Split mirror restore" on the next page](#).

Standard restore

Data is restored from the backup media to the application system through a LAN. Only selected backed up objects are restored. For more information on this restore type, see the *HPE Data Protector Help* index: "restore".

Tip: You can improve the data transfer rate by connecting a backup device to the application system. For information on configuring backup devices, see the *HPE Data Protector Help* index: "backups devices: configuring". For information on performing a restore using another device, see the *HPE Data Protector Help* index: "selecting, devices for restore".

The procedure below is a general description of restoring the objects backed up in a ZDB session.

1. In the **Context List**, select **Restore**.
2. Select the objects for restore and click them to display their properties.
In the Scoping Pane, select the application system as **Target client** under the **Destination** tab.
For information on restore options, press **F1**.
3. Click **Restore**. The **Start Restore Session** dialog box appears.
4. Click **Next** to specify the report level and network load. Click **Next**.
5. In the **Start Backup Session** window, select **Disabled** as **EMC Symmetrix mode**. This sets a restore from backup media on LAN. See ["Restore from backup media on LAN " on the next page](#).

Restore from backup media on LAN

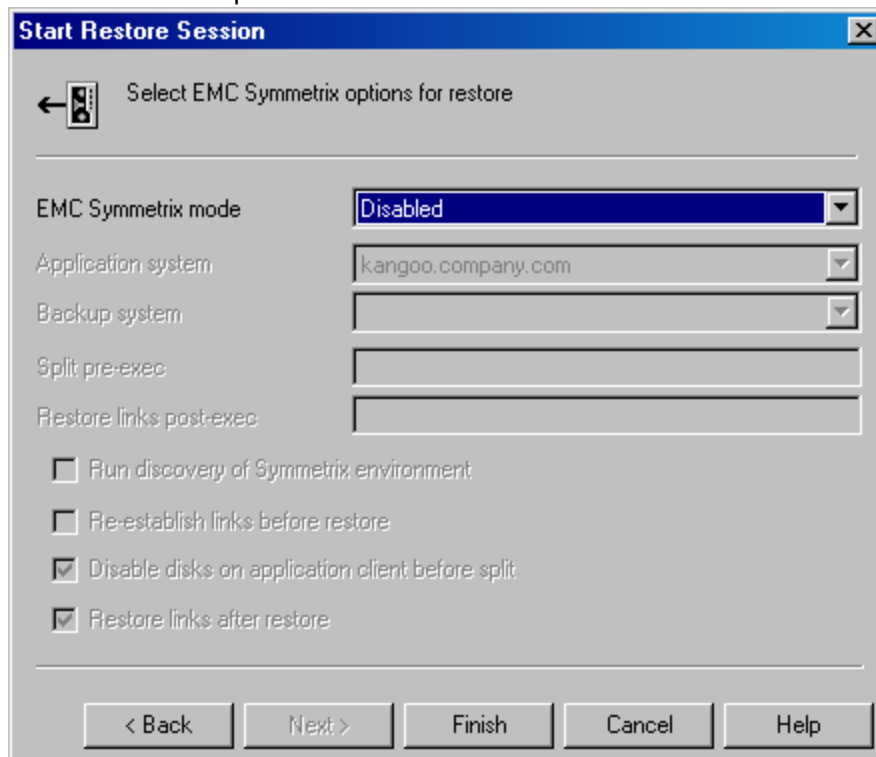

6. Click **Finish** to start the restore.

Split mirror restore

Split mirror restore consists of the following automated steps:

1. Preparing the backup and application systems.
2. Restoring data from backup media on LAN to the backup system and synchronizing this data to the application system.

For a description of a split mirror restore process, see the *HPE Data Protector Concepts Guide*.

Split mirror restore procedure

1. In the Context List, select **Restore**.
2. Select the objects for restore and click them to display their properties.

Note: Select the application system as **Target client** under the **Destination** tab. If the backup system is selected, standard restore to the backup system is performed.

3. Click **Restore**. The **Start Restore Session** dialog box appears.
4. Click **Next**.
5. Specify the report level and network load. Click **Next**.
6. Select **EMC Symmetrix restore**. Click **Next**.

Specify the split mirror restore options. See ["EMC Symmetrix split mirror restore options "](#) below. For more information, see ["Split mirror restore options"](#) below.

EMC Symmetrix split mirror restore options

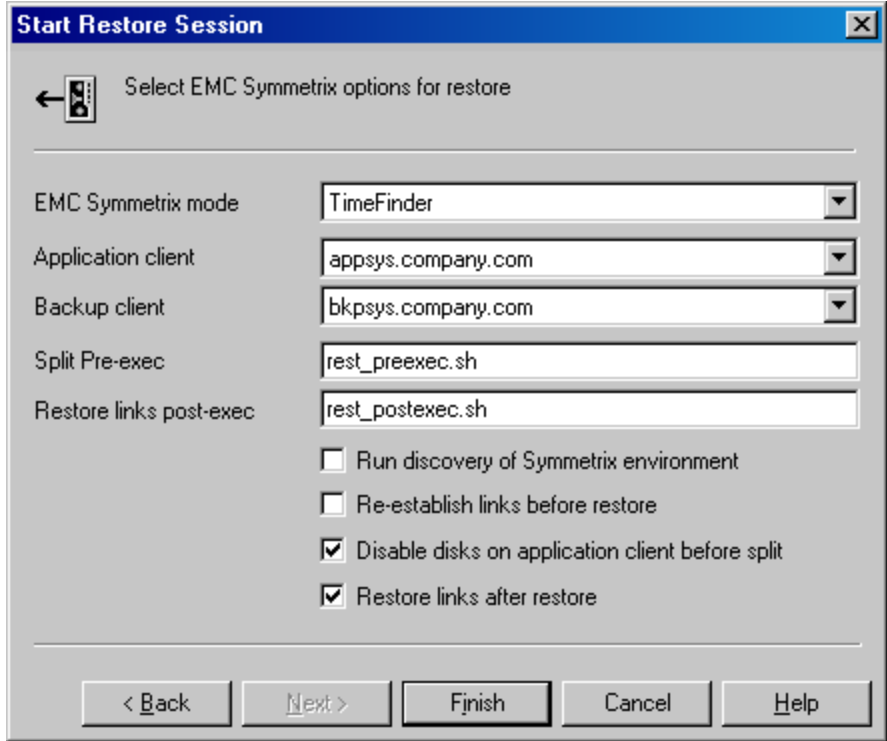

- 7.
8. Click **Finish** to start the split mirror restore.

You cannot start split mirror backup/restore using the same disk on the application system at the same time. A split mirror session must be started only after the preceding session using the same disk on the application system finishes synchronization; otherwise, the session fails.

Split mirror restore options

The following table explains split mirror restore options.

EMC split mirror restore options

Data Protector GUI	Function
EMC Symmetrix mode	EMC Symmetrix configuration: TimeFinder, SRDF, or Combined (SRDF + TimeFinder).
Application system	The system on which the application runs. In cluster environments, specify the virtual server hostname (rather than the physical node hostname).
Backup system	The system to which your data is first restored. In cluster environments, specify the virtual server hostname (rather than the physical node hostname).

Data Protector GUI	Function
<p>Split pre-exec</p>	<p>Specify the Split pre-exec command, executed before the split. Create the command the default Data Protector administrative commands directory on the application system. This command can be used to stop applications and dismounting filesystems (HP-UX only) that are not to be restored in the active session, and are mounted to the volume groups that will be restored in the same session. This prepares volume groups for de-activation.</p> <p>Restore session is not aborted if the command set by this option is not executed.</p> <p>If Split pre-exec fails, Restore links post-exec (see below) is also not executed. Therefore, you need to implement a cleanup procedure in Restore links post-exec.</p> <p>If the ZDB_ALWAYS_POST_SCRIPT omnirc option is set to 1, Restore links post-exec is always executed if set (default is 0). See "Appendix" on page 228 for more information.</p>
<p>Restore links post-exec</p>	<p>Specify the Restore links post-exec command, executed after the links are restored. Create the command in the default Data Protector commands directory on the application system. It is used to remount filesystems (HP-UX only) and restart applications.</p> <p>Do not use this command to enable applications if you disabled Re-establish links after restore. Applications using restored disks must not be restarted until the links are manually established.</p>
<p>Run discovery of Symmetrix environment</p>	<p>Builds/re-builds the Data Protector EMC database on both the application and backup systems. See "Configuration" on page 157 for more information.</p> <p>Default: not selected.</p>
<p>Re-establish links before restore</p>	<p>Synchronizes split disks (moves data to backup disks) thus preparing disks for restore.</p> <p>Default: not selected.</p>
<p>Disable disks on application client before split</p>	<p>Disables disks on the application system by dismounting filesystems and de-activating volume groups (HP-UX) before the split. The disks are enabled after restore.</p> <p>Always select this option when you want to move data from the backup to the application system, that is, to incrementally restore links. Application system disks must be disabled to provide data integrity after restore.</p>

Data Protector GUI	Function
Restore links after restore	Incrementally restores links of devices, successfully restored to the backup system. Links of devices that were not successfully restored are incrementally re-established.

The chart below provides detailed split mirror restore flow according to the options selected.

Split mirror restore flow

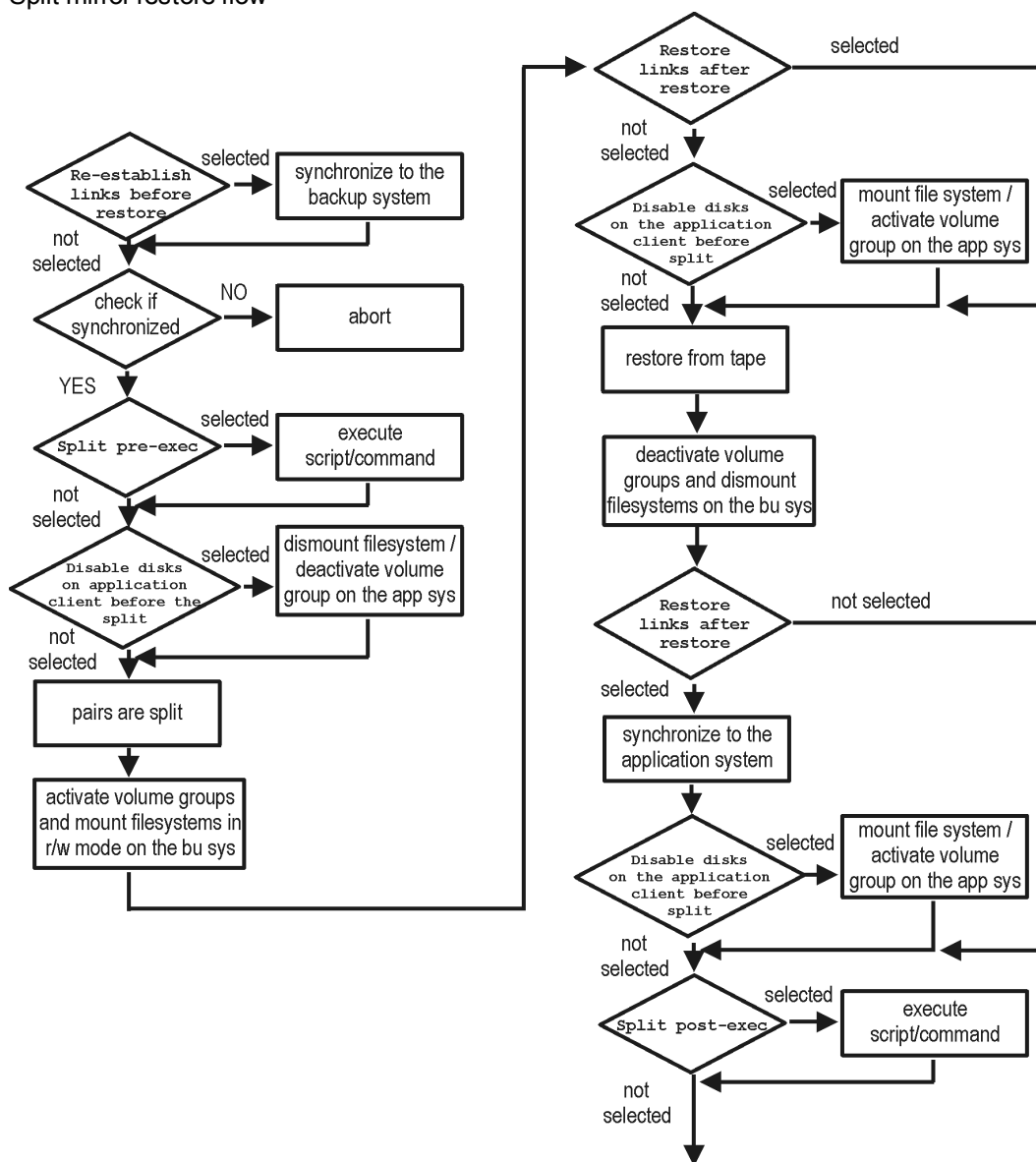

Split mirror restore in a cluster

Split mirror restore in configurations with the application system in HPE Serviceguard or a Microsoft server cluster requires additional steps. For details, see the sections that follow.

HPE Serviceguard procedure

1. Stop the filesystem cluster package:

```
cmhaltpkg ApplicationPackageName
```

This stops filesystem services and dismounts the mirrored volume group filesystem.

2. Deactivate the mirrored volume group from the cluster mode and activate it in the normal mode:

```
vgchange -c n /dev/mirror_vg_name
```

```
vgchange -q n -a y /dev/mirror_vg_name
```

3. Mount the mirrored volume group filesystem:

```
mount /dev/mirror_vg_name /Lv_name /mountpoint
```

4. Start split mirror restore (see ["Split mirror restore procedure" on page 170](#)).

When specifying the application system, specify the hostname of the application system *node* on which the mirrored volume group was activated in the normal mode ("[Deactivate the mirrored volume group from the cluster mode and activate it in the normal mode:](#)" above of this procedure).

5. After restore, dismount the mirrored volume group filesystem:

```
umount /mountpoint
```

6. Deactivate the mirrored volume group in the normal mode and activate it in the cluster mode:

```
vgchange -a n /dev/mirror_vg_name
```

```
vgchange -c y /dev/mirror_vg_name
```

7. Start the filesystem cluster package:

```
cmrunpkg ApplicationPackageName
```

Chapter 20: Troubleshooting

Before you begin

This chapter lists general checks and verifications, and problems you may encounter when using the EMC integration. For general Data Protector troubleshooting information, see the *HPE Data Protector Troubleshooting Guide*.

- Ensure that the latest official Data Protector patches are installed. For information on how to verify this, see the *HPE Data Protector Help* index: “patches”.
- For general Data Protector and integration-specific limitations, as well as recognized issues and workarounds, see the HPE Data Protector Product Announcements, Software Notes, and References.
- For an up-to-date list of supported versions, platforms, and other information, see <https://softwaresupport.hpe.com/>.

Checks and verifications

- On the application and backup systems, examine system errors reported in the `debug.log` file residing in the default Data Protector log files directory.

Backup problems

Problem

You cannot select EMC mode in the Data Protector GUI when creating a backup specification

Action

Check that the EMC Symmetrix Agent integration module is installed on the application and backup systems. To do that, open the `cell_info` file located on the Cell Manager in the following directory:

Windows Systems: `Data_Protector_program_data\Config\server\cell\cell_info`

UNIX system: `/etc/opt/omni/server/cell/cell_info`

File contents should look similar to the following:

```
-host "hpsap001.bbn.hp.com" -os "HP s800 hp-ux-11.00"  
-cc A.09.00 -da A.09.00 -emc A.09.00  
-host "hpsap002.bbn.hp.com" -os "HP s800 hp-ux-11.00"  
-cc A.09.00 -da A.09.00 -ma A.09.00 -emc A.09.00
```

Problem

On the application system, dismounting a filesystem fails

Action

In `Split pre-exec` script, stop all processes using the filesystem.

Problem

Disks synchronization fails (split fails)

To successfully split the disks, EMC Agent first checks the status of the links. Links can only be split after all devices are synchronized. EMC Agent checks the status of links every 30 seconds and retries 15 times.

Action

Increase the time frame for synchronization by setting `SYMA_SYNC_RETRY` and `SYMA_SLEEP_FOR_SYNC` omnirc options.

See ["Appendix" on page 228](#) for more information.

Problem

EMC device is not part of a BCV pair

Action

If the TimeFinder or SRDF + TimeFinder configuration is used, check that all backup disks on the application system have an associated BCV device on the backup system.

Problem

Device group cannot be created

Action

Check if any of the previous sessions was improperly stopped, and run EMC Agent recovery for this session on the backup system. See ["Recovery using the EMC agent" on page 184](#) for instructions.

Problem

Adding a device into a device group/associating BCV to a device group fails

Action

Check if any of the previous backups was improperly stopped, and run EMC Agent recovery for this session on the backup system. See ["Recovery using the EMC agent" on page 184](#) for instructions.

Problem

Volume group on the backup system cannot be de-activated

Action

Stop the processes that run on the volume group filesystem.

Problem

Rebuilding the Data Protector EMC database fails

Action

Execute a discovery from:

Windows systems: `Data_Protector_home\bin\syma -init`

UNIX systems: `/opt/omni/lbin/syma -init`

on both the application and backup systems. If the operation succeeds, disable the `Run discovery of Symmetrix environment` option and restart the backup.

If discovery fails, execute the `symcfg discover` command.

Problem

Resolving an object fails

Action

Check the EMC Agent log file on the application system and ensure that all objects logged into this file are created on the mirrored EMC devices.

Problem

Invalid link state on the EMC device

Action

Check the link state. If it is split, set the **Re-establish links before backup** option.

Problem

Preparation of the backup system fails when VxVM is used

This problem may be caused by the following:

- If a backup specification involves VxVM volume groups, EMC arrays do not support I/O on a BCV device in a synchronized state.
- The information about volume groups is not added to the VxVM configuration.

Action

1. Check if any backup objects in the backup specification belong to VxVM disk groups.
2. If there are objects belonging to VxVM volume groups, proceed as follows:
 - a. Check if a BCV is visible on the backup system.
 - b. Check the synchronization state of the BCV devices. If the BCV devices are synchronized, split them.
 - c. Execute `vxdisk scandisks`.
 - d. Re-establish the mirror.

Error messages

This section provides information on error messages.

Message

```
[Major] From: SYMA@Backup (R2) System "" Time: 04/03/13 09:18:34  
[223:324] SYMA-R2 Could not add device 048 from Symmetrix 000282600317 to device  
group SYMA_REG_2013-03-04-2_0.  
(SYMAPI-The device is already a member of a device group)
```

One of previous sessions failed.

Actions

- Run a recovery of the failed session to create a consistent environment.
- Check that the /var directory is not full (if it is full, EMC Agent does not have enough space to write its record into the file; the session then fails). Clean the directory and restart the session.

Message

```
[Major] From: SYMA@Application (R1) System "" Time: 11/03/13 15:06:22  
[223:193] SYMA-R2 Could not activate volume group /dev/xf1_fs2_b
```

Backup volume group is not deactivated or there is a problem with configuration.

Actions

- Run the same backup with debug on, and then check the EMC Agent R2 debug file on the backup system for LVM error messages.
- Try to split links and activate the backup volume group manually. If this is not done, the backup may fail with an error [223:193].

Message

```
[Major] From: SYMA@Application (R1) System "" Time: 3/31/13 11:32:58 AM  
[223:406] Failed to initialize the SYMAPI session  
(SYMAPI-The version of the symapi library is too old; please  
upgrade to a newer version of SYMAPI)
```

Action

Check the EMC Solution Enabler version.

Message

```
[Major] From: SYMA@Application (R1) System "" Time: 6/30/13 10:57:00 AM  
[223:408] Failed to re-sync Symmetrix database. (SYMAPI-No Symmetrix  
devices were found)
```

Action

Run the same session with the option **Run discovery of Symmetrix environment**.

Message

```
[Major] From: SYMA@Application (R1) System "" Time: 3/31/13 2:17:43 PM
[223:407] Failed to rescan host devices and rebuild Symmetrix database
SYMAPI-Error opening the gatekeeper device for communication to the
Symmetrix)
```

Actions

- Execute `symcfg discover`. If the problem persists, check the pseudo-devices file.
- If the device you want to use as a gatekeeper or BCV device is accessed through the HP-PB (NIO) SCSI bus controller, create pseudo-devices for all gatekeepers and BCV devices.
- See README file in `/var/symapi/config/README.pseudo_devices`.

Message

```
[Major] From: SYMA@Backup (R2) System "" Time: 5/11/13 12:01:11 PM
[223:335] SYMA-R2 Failed to synchronize SRDF links in device group
SYMA_RDF2_2013-05-11-21_0 before backup. (SYMAPI-The operation failed
because another process has an exclusive lock on a locally-attached
```

Symmetrix)

```
[Major] From: SYMA@Backup (R2) System "" Time: 5/11/13 12:01:13 PM
SYMA-R2 Invalid SRDF link state of device 000 from Symmetrix
000282600317 (links state=103)
```

Devices are not synchronized.

Action

Manually establish the links or use the option `Establish Links Before Backup`. If the problem persists, execute:

```
symrdf -g Dg_name establish -bypass
```

Caution: See the `symrdf` man page about the `bypass` option before executing this command.

Message

```
[Major] From: SYMA@twingo "" Time: 6/7/13 1:08:30 PM
[223:301] SYMA-R2 Device 006 from Symmetrix 000182600287 is not
part of a BCV pair
```

Actions

- Check backup options in the backup specification.
- Check the configuration in the backup specification.

Message

```
[Major] From: SYMA@Backup (R2) System "" Time: 8/4/13 3:26:27 PM
SYMA-R2 Invalid SRDF link state of device 001 from Symmetrix
```

```
000282600317 (links state=103)
[Major] From: SYMA@Backup (R2) System "" Time: 8/4/13 3:26:28 PM
[223:361] SYMA-R2 Split of links(s), which belong to the object
/dev/rdisk/c1t8d0, has failed. (Unexpected state of rdf link)
```

Connection between EMC R1 and R2 devices is not established.

Action

Run the same session with the option `Re-establish links before backup`.

Message

```
[Major] From: SYMA@Backup (R2) System "" Time: 8/30/13 11:37:12 AM
[223:125] SYMA-R2 Resolving of object /RDF/fs/HFS has failed
(Volume group is not deactivated)
```

Volume group on the backup system is still activated.

Action

On the backup system, split the links and deactivate the backup volume group. Re-establish the links manually, or select the option `Re-establish links before backup` in the backup specification.

Split mirror restore problems

Problem

Deactivating volume groups during restore fails (HP-UX only)

Action

In the `Split pre-exec` script, stop all processes using the affected volume groups and dismount all filesystems created on these volume groups that are not to be restored in the current session.

Problem

Disks synchronization fails (split fails)

To successfully split the disks, EMC Agent first checks the status of the links. Links can only be split after all devices are synchronized. EMC Agent checks the status of links every 30 seconds and retries 15 times.

Action

Increase the time frame for synchronization by setting `SYMA_SYNC_RETRY` and `SYMA_SLEEP_FOR_SYNC` omnirc options.

See ["Appendix" on page 228](#) for more information.

Problem

EMC device is not part of a BCV pair

Action

If the TimeFinder or SRDF + TimeFinder configuration is used, check that all backup disks on the application system have an associated BCV device on the backup system.

Problem

Device group cannot be created

Action

Check if any of the previous sessions was improperly stopped, and run EMC Agent recovery for this session on the backup system. See ["Recovery using the EMC agent" on page 184](#) for instructions.

Problem

Adding a device into a device group/associating BCV to a device group fails

Action

Check if any of the previous backups was improperly stopped, and run EMC Agent recovery for this session on the backup system. See ["Recovery using the EMC agent" on page 184](#) for instructions.

Problem

Rebuilding the Data Protector EMC database fails

Action

Run a discovery from:

Windows systems: `Data_Protector_home\bin\syms -init`

UNIX systems: `/opt/omni/lbin/syms -init`

on both the application and backup systems. If the operation succeeds, disable the `Run discovery of Symmetrix environment` option and restart the backup.

If discovery fails, execute the `symcfg -discover` command.

Problem

Resolving an object fails

Action

Check the EMC Agent log file on the application system and ensure that all objects logged into this file are created on the mirrored EMC devices.

Problem

Invalid link state on the EMC device

Action

Check the state of the link. If it is split, set the `Re-establish links before backup` option.

Error messages

This section provides information on error messages.

Message

```
[Major] From: SYMA@Backup (R2) System "" Time: 04/03/13 09:18:34  
[223:324] SYMA-R2 Could not add device 048 from Symmetrix 00028260031 to device  
group SYMA_REG_2013-03-04-2_0.  
(SYMAPI-The device is already a member of a device group)
```

One of previous sessions failed.

Actions

- Run a recovery of the failed session to create a consistent environment.
- Check that the /var directory is not full (if it is full, EMC Agent does not have enough space to write its record into the file; the session then fails). Clean the directory and restart the session.

Message

```
[Major] From: SYMA@Application (R1) System "" Time: 11/03/13 15:06:22  
[223:193] SYMA-R2 Could not activate volume group /dev/tf1_fs2_b
```

Backup volume group is not deactivated or there is a problem with configuration.

Actions

- Run the same backup with debug on, and then check the EMC Agent R2 debug file on the backup system for LVM error messages.
- Try to split links and activate the backup volume group manually. If this is not done, the backup may fail with an error [223:193].

Message

```
[Major] From: SYMA@Application (R1) System "" Time: 3/31/13 11:32:58 AM  
[223:406] Failed to initialize the SYMAPI session  
(SYMAPI-The version of the symapi library is too old; please upgrade  
to a newer version of SYMAPI)
```

Action

Check the EMC Solution Enabler version.

Message

```
[Major] From: SYMA@Application (R1) System "" Time: 6/30/13 10:57:00 AM  
[223:408] Failed to re-sync Symmetrix database. (SYMAPI-No Symmetrix  
devices were found)
```

Action

Run the same session with the option `Run discovery` of Symmetrix environment.

Message

```
[Major] From: SYMA@Application (R1) System "" Time: 3/31/13 2:17:43 PM
[223:407] Failed to rescan host devices and rebuild Symmetrix database
SYMAPI-Error opening the gatekeeper device for communication to the Symmetrix)
```

Actions

- Try to execute `symcfg discover`. If the problem persists, check the pseudo-devices file.
- If the device you want to use as a gatekeeper or BCV device is accessed through the HP-PB (NIO) SCSI bus controller, create pseudo-devices for all gatekeepers and BCV devices.
- See README file in `/var/symapi/config/README.pseudo_devices`.

Message

```
[Major] From: SYMA@Backup (R2) System "" Time: 5/11/13 12:01:11 PM
[223:335] SYMA-R2 Failed to synchronize SRDF links in device group
SYMA_RDF2_2013-05-11-21_0 before backup. (SYMAPI-The operation
failed because another process has an exclusive lock on a
locally-attached Symmetrix)
[Major] From: SYMA@Backup (R2) System "" Time: 5/11/13 12:01:13 PM
SYMA-R2 Invalid SRDF link state of device 000 from Symmetrix 000282600317
(links state=103)
```

Devices are not synchronized.

Action

Manually establish links or use the option `Re-establish Links Before Restore`. If the problem persists, execute:

```
symrdf -g Dg_name establish -bypass
```

Caution: See the `symrdf` man page about the `bypass` option before executing this command.

Message

```
[Major] From: SYMA@twingo "" Time: 6/7/13 1:08:30 PM
[223:301] SYMA-R2 Device 006 from Symmetrix 000182600287 is not
part of a BCV pair
```

Actions

Check the restore options.

Message

```
[Major] From: SYMA@Backup (R2) System "" Time: 8/4/13 3:26:27 PM
SYMA-R2 Invalid SRDF link state of device 001 from Symmetrix
000282600317 (links state=103)
[Major] From: SYMA@Backup (R2) System "" Time: 8/4/13 3:26:28 PM
```

```
[223:361] SYMA-R2 Split of links(s), which belong to the object  
/dev/rdisk/c1t8d0, has failed. (Unexpected state of rdf link)
```

Connection between EMC R1 and R2 devices is not established.

Action

Run the same session with the option `Re-establish links before restore`.

Message

```
[Major] From: SYMA@Backup (R2) System "" Time: 8/30/13 11:37:12 AM  
[223:360] SYMA-R2 Resolving of object /RDF/fs/HFS has failed  
(Volume group is not deactivated)
```

Volume group on the backup system is still activated.

Action

- On the backup system, split the links and deactivate the backup volume group. Re-establish the links manually or select the option `Re-establish links before restore` in the backup specification.

Recovery using the EMC agent

If a backup or other operation did not finish successfully, the EMC environment is left in an undefined state, for example, with links split, device groups not deleted in the Data Protector EMC database file, filesystems on the backup system mounted, volume groups on the backup system activated, and so on.

In this case, invoke the EMC Agent (SYMA) `recovery` command to recover the environment. Information about EMC Agent objects, device groups, and volume groups is logged in the EMC Agent recovery files:

Windows systems:

```
Data_Protector_home\Config\Emc\symmR1.rec
```

```
Data_Protector_home\Config\Emc\symmR2.rec
```

HP-UX systems:

```
/var/opt/omni/emc/symmR1.rec
```

```
/var/opt/omni/emc/symmR2.rec
```

When a record is entered, it is marked as valid. If the session is not successful, the record is marked as invalid. Invalid records are automatically deleted when the EMC Agent recovery file exceeds a certain value, by default, `SYMA_REC_FILE_LIMIT = 102400` bytes.

To recover the environment, invoke the following command that re-establish links and delete device groups. Next split mirror backup or split mirror restore will dismount filesystems and de-activate volume groups on the backup system.

- On the application system:
Windows systems: `Data_Protector_home\bin\symsa -r1 -session sessionID -recovery`
HP-UX systems: `/opt/omni/lbin/symsa -r1 -session sessionID -recovery`
 - On the backup system:
Windows systems: `Data_Protector_home\bin\symsa -no_r1 -session sessionID -recovery [-split]`
HP-UX systems: `/opt/omni/lbin/symsa -no_r1 -session sessionID -recovery [-split]`
- You can obtain `sessionID` from the Data Protector GUI as shown in "Obtaining session ID " below.

Obtaining session ID

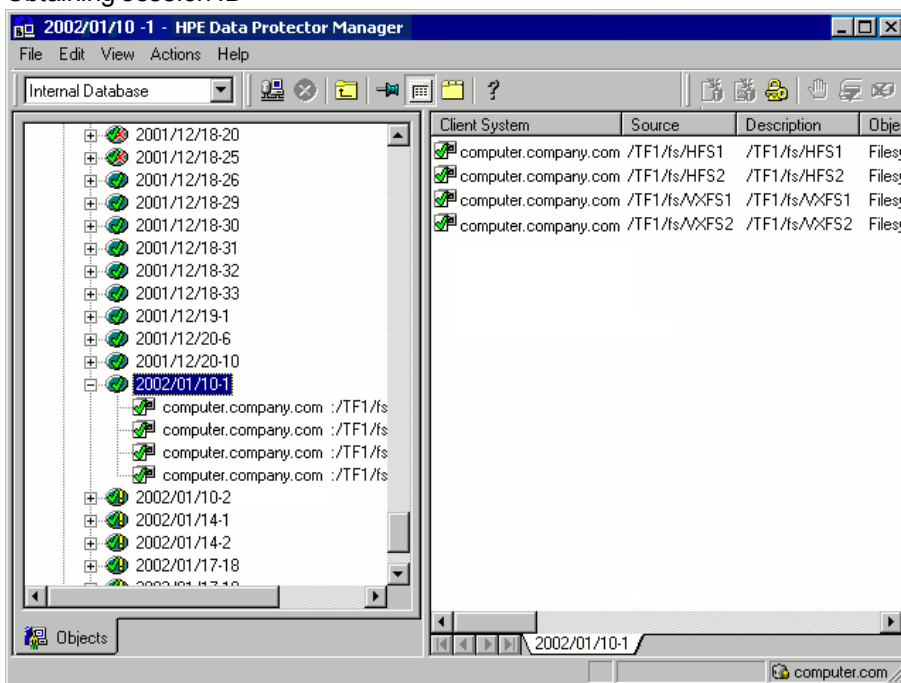

The `split` option disables synchronization of links.

This command reads the recovery file and recovers the state of the environment before the session.

Note: Do not edit or restore the EMC Agent recovery file.

Part 6: NetApp Storage

This part describes how to configure the Data Protector NetApp Storage integration, how to perform zero downtime backup using the NetApp Storage system, and how to resolve the integration-specific Data Protector problems.

Chapter 21: Configuration

Introduction

This chapter describes the configuration of the Data Protector NetApp Storage integration. It also provides information on the Data Protector ZDB database and lists prerequisites and limitations.

Prerequisites

- Make sure the same operating system version is installed on both the application system and the backup system.
- If the application system and the backup system reside in a Data Protector cell with secured clients, ensure that access between both systems is allowed in both directions.
- Connect a NetApp storage system to the application and backup systems through the SAN.
- Source volumes must have enough space for snapshots and clones

NetApp Storage licenses and components

- Obtain FC/FCoE license for accessing LUNs on the NetApp storage system.
- Obtain SANworks Snapshot licenses.
- Enable the httpd admin access or SSL encrypted admin connection, or both by running the following commands on the NetApp console:

```
netapp1> options httpd.admin.enable on  
netapp1> httpd.admin.ssl.enable on
```

- Make sure that the names of Initiator Groups on the NetApp storage system are the same as the fully-qualified domain names of the systems they represent.
- Make sure that an appropriate multi-path device management is installed on the application system and the backup system.

Linux systems: HPE Device Mapper Multipath Enablement Kit for HPE Disk Arrays 4.2.0 or newer version.

To configure the installed multi-path device management software:

- a. Start the multipath daemon and run the following command to configure the daemon so that it gets started during system startup:

Red Hat Enterprise Linux: `chkconfig multipathd on`

SUSE Linux Enterprise Server: `chkconfig boot.multipath on`

- b. Prevent the multipath device management software from queuing for unavailable disk volumes by modifying its configuration file. In the `defaults` section of the file `/etc/multipath.conf` file, add the following line:

```
no_path_retry          fail
```

Ensure that this `no_path_retry` parameter value is not overridden by equivalent entries in the device sections of the same file in which the corresponding NetApp storage systems are configured.

- c. Ensure that the correct preferred names are used for pathnames that are referencing the same device for physical volumes as they are used in device-mapper multipathing.

Open the `lvm.conf` file, residing in the `/etc/lvm/` directory, and set the following variable:

```
preferred_names = [ "^/dev/mpath/", "^/dev/mapper/mpath", "^/dev/[hs]d" ]
```

Windows systems: Microsoft MPIO configured for NetApp Storage Provider. For more information, see the NetApp documentation.

Data Protector licenses and components:

- An appropriate zero downtime backup extension for non-HPE Storage Arrays licenses-to-use (LTU).
- The NetApp Storage Provider component installed on both the application system and the backup system.

For licensing information and installation and upgrade instructions, see the *HPE Data Protector Installation Guide*.

Prerequisites for Windows systems

- On Windows Server 2003 and Windows Server 2008 systems, disable the operating system option **Automatic mounting of new volumes**. In the Command Prompt window, run the command `mountvol /N`.
- Do not manually mount target volumes that were created by Data Protector.

Limitations

- In cluster environments, the backup system must not be in the same cluster with the application system. Additionally, the backup system cannot be the cluster virtual server, it can only be a cluster node.
- Instant recovery is not supported.

For information on the following items, see the HPE Data Protector Product Announcements, Software Notes, and References:

- General Data Protector and integration-specific limitations
- Supported platforms and integrations
- Supported backup and connectivity topologies

ZDB database - SMISDB

ZDB database for the Data Protector NetApp Storage integration is referred to as SMISDB. It keeps information about NetApp storage systems. For each system, the following is stored:

- Hostname as recognized in the IP network.
- User name and encoded password for the NetApp Storage Provider login

SMISDB resides on the Cell Manager in:

Windows systems: `Data_Protector_program_data\server\db80\smisdb`

UNIX systems: /var/opt/omni/server/db80/smisdb

Configuring the integration

Before you start with the configuration, make sure the prerequisites listed in "Introduction" are fulfilled.

To integrate with the NetApp storage system, Data Protector uses the NetApp Storage Provider. This plug-in enables NetAPP storage support within the Data Protector ZDB (SMI-S) agent. To configure the Data Protector NetApp Storage integration, provide the data that the Data Protector ZDB agent will use to establish connection to a NetApp storage system of your choice.

The connection configuration data includes user credentials that you must add to the ZDB database (the NetApp part of SMISDB). The credentials are bound to a specific application system in the Data Protector cell. The Data Protector ZDB agent then reads the credentials from the ZDB database each time a zero downtime backup for data residing on a NetApp storage system is started.

Connection configuration data

To be able to connect to a NetApp storage system and perform zero downtime backup sessions, the Data Protector ZDB agent needs the following information:

- Fully qualified domain name or IP address of the system where the NetApp Storage Provider resides
If the system has multiple IP addresses, use the address by which the Data Protector ZDB agent can access the system.
- Whether the connection uses Secure Sockets Layer (SSL)
- Username and password
These credentials must belong to the NetApp storage system Administrator account. For more information on using the NetApp authorization system and on NetApp user groups, see the NetApp documentation.

You need to provide the above information to enable connection between the Data Protector ZDB agent and the NetApp Storage system. It is stored in the NetApp part of the SMISDB.

Configuration procedure

To establish connection to the NetApp storage system, use the Data Protector `omnidbzd` command. Follow the steps:

1. Select the NetApp storage system user account that has a proper privilege level on the corresponding domains. Identify and write down its username and password, which you will need in the next step.
2. Use the `omnidbzd` command to establish connection to the NetApp storage system and to add the username and password that you acquired in the previous step to the ZDB database. Run the following command:

```
omnidbzd --diskarray ArrayFamily --ompasswd --add ClientName --user UserName -  
-passwd password
```

where:

ArrayFamily - NetApp

ClientName - fully qualified domain name of the NetApp storage system

UserName and *password* - user credentials that you acquired in the previous step

For example:

```
omnidbzd --diskarray NetApp --ompasswd --add netappstorage.company.com --user  
Administrator --passwd pwd
```

For command syntax and usage examples, see the `omnidbzd` reference page in the *HPE Data Protector Command Line Interface Reference* or the `omnidbzd man` page.

3. Using the `omnidbzd --diskarray NetApp --ompasswd --check` command, verify that the Data Protector NetApp Storage Provider can connect to the NetApp storage system using the configured user authentication data.

Tip: For each application system, you can add user credentials of multiple NetApp Storage user accounts. When several are configured for the same system, the Data Protector ZDB agent checks user accounts in alphabetical order and uses the first account with *Edit* privilege level on the application system and the source volumes.

For information on performing other tasks related to management of user credentials in the ZDB database, see the `omnidbzd` reference page in the *HPE Data Protector Command Line Interface Reference* or the `omnidbzd man` page.

Chapter 22: Backup

This chapter describes configuration of a filesystem or disk image ZDB using the Data Protector GUI.

With the NetApp Storage Provider integration, you can perform the zero downtime backup of the ZDB to tape type only. For more information on the ZDB types, see the *HPE Data Protector Concepts Guide*.

You should be familiar with the NetApp storage concepts and procedures and basic Data Protector ZDB functionality. See the NetApp storage-related documentation and the *HPE Data Protector Concepts Guide*.

For information on the supported configurations, ZDB types and replication techniques available on this storage system, and storage system-specific ZDB considerations, see the *HPE Data Protector Concepts Guide*.

Creating backup specification

Limitations

- Only one snapshot type for target volumes can be created during a ZDB session.
- When cloning process for a source volume is in progress, another snapshot (any type) of that source volume cannot be created.
- You cannot back up replicas (target volumes from existing and currently recorded backup sessions).
- If there is not enough space for a fully allocated replica creation, the session fails.

Considerations

- Consider all limitations that apply to the Data Protector NetApp Storage integration. See the HPE Data Protector Product Announcements, Software Notes, and References, the *HPE Data Protector Concepts Guide*, and the limitation list in "[Configuration](#)".

Procedure

To create a ZDB backup specification for a NetApp storage using the Data Protector GUI (Data Protector Manager), follow the steps:

1. In the Context List, select **Backup**.
2. In the Scoping Pane, expand **Backup Specifications**. Right-click **Filesystem** (for both object types: filesystem and disk image) and click **Add Backup**.

The Create New Backup dialog box appears.

In the Filesystem pane, select the **Blank Filesystem Backup** template or some other available template. For information on templates, see the *HPE Data Protector Help* index: "backup templates".

Select **Snapshot or split mirror backup** as Backup type and **Storage Provider** as Sub type. For description of options, press **F1**.

Click **OK**.

- Under Client systems, select **Application system** and **Backup system**. If the application system is part of a server cluster, select the virtual server.

NetApp Storage zero downtime backup options

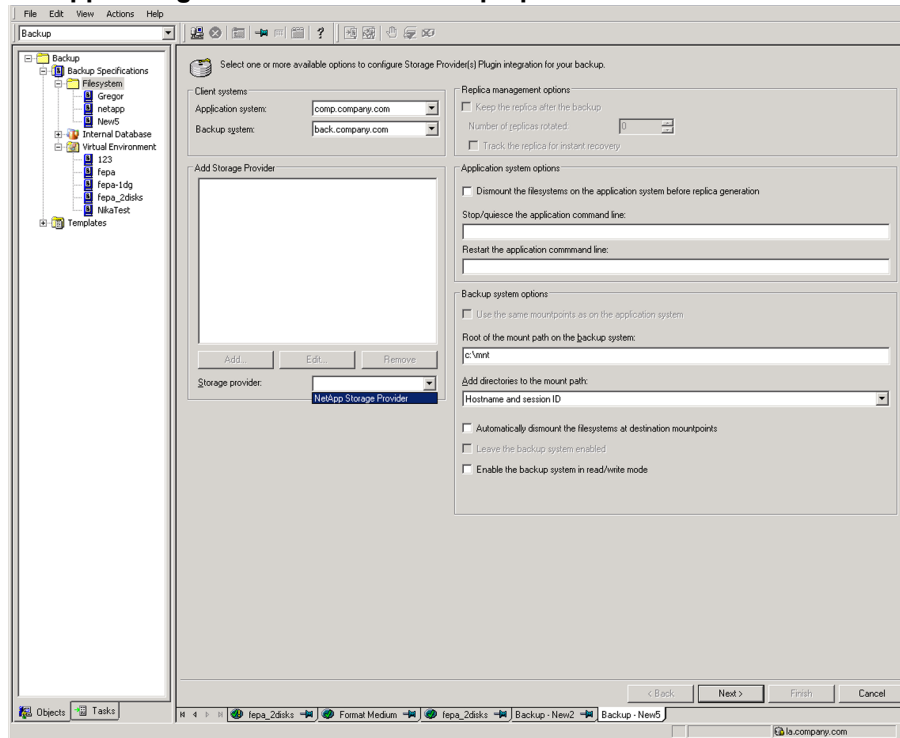

- Under Add Storage Provider, select **NetApp Storage** from the Storage provider drop-down list and then click **Add**. The NetApp Storage Options dialog opens. Select a **Thin provisioned** or **Fully allocated** replica provision type, enter a replica description, and then click **OK**. The NetApp Storage is added to a list. You can later change its options by clicking **Edit** or remove it from the list by clicking **Remove**. For more information, press **F1**.
- Under Application system options and Backup system options, specify other zero downtime backup options as required. For information, see "[Backup options](#)" or press **F1**.

Click **Next**.

- Select the objects for backup.
 - Filesystem backup:** Expand the application system and select the objects to back up. Note that all drive letters or mount points that reside on the system are displayed. You must select only the objects that reside on the NetApp storage system, otherwise the ZDB session fails. Click **Next**.

- Disk image backup:** Click **Next**.

- Select the devices to use in the backup session.

To create additional copies (mirrors) of the backup image, specify the number of mirrors by clicking **Add mirror** or **Remove mirror**. Select separate devices for the backup image and each mirror.

For information on object mirroring, see the *HPE Data Protector Help* index: "object mirroring".

Click **Next**.

8. In the Backup Specification Options group box, click **Advanced** and then the **Storage Provider** tab to open the options pane with NetApp storage specific backup options.

You can specify Application system options and modify all other options, except **Application system** and **Backup system** (note that you can change them after you save the ZDB backup specification). See "[Backup](#)" on page 191 or press **F1**.

Click **Next**.

9. Schedule the ZDB sessions. For more information, see "[Appendix](#)" on page 228 or press **F1**.

Click **Next**.

10. In the Backup Object Summary page, specify additional options.

- **Filesystem backup:** To modify options for the listed objects, right-click an object and then click **Properties**. For information on the object properties, press **F1**.
- **Disk image backup:** Follow the steps:
 - i. Click **Manual add** to add disk image objects.
 - ii. Select **Disk image object** and click **Next**.
 - iii. Select the client system. Optionally, enter the description for your object. Click **Next**.
 - iv. Specify General Object Options and Advanced Object Options. For information on these options, press **F1**.
 - v. In the Disk Image Object Options window, specify disk image or raw logical volume sections.
 Specify a disk image section:
/dev/rdisk/FileName, for example: */dev/rdisk/c2t0d0*
 Specify a raw logical volume section:
/dev/vgnumber/r1volNumber, for example: */dev/vg01/r1vol1*
 - vi. Click **Finish**.

Click **Next**.

11. Save your ZDB backup specification.

Backup options

The following tables describe the ZDB-related backup options that you can modify when configuring ZDB backup specifications that include storage systems of the NetApp Storage family.

Client systems

Application system	The system on which the application runs. In cluster environments, specify the virtual server hostname (rather than the physical node hostname).
Backup system	The system to which your data will be replicated (backed up), and from which the backup data is copied to a backup device.

NetApp storage replica provision options

<p>Thin provisioned</p>	<p>Select this replica provision type to provision more storage on a LUN than is currently available on the volume, thus increasing the capacity utilization of that volume. It allows free space sharing between LUNs and enables LUNs to consume only the space they actually use.</p> <p>With thin provisioning, you can present more storage space to the backup system connected to the NetApp storage than is actually available to provide the storage you need at any given time.</p>
<p>Fully allocated</p>	<p>Select this replica provision type to enable space-reserved LUNs and snapshot copies have pre-allocated space that can be continually overwritten. This guaranteed space is not available to any other LUNs or snapshot copies within the volume.</p>

Application system options

<p>Dismount the filesystems on the application system before replica generation</p>	<p>Select this option to dismount the filesystems on the application system before replica creation and remount them afterwards. Additionally, when entire physical drives (on Windows systems) or entire disks or logical volumes (on UNIX systems) are selected as backup objects in a disk image backup specification, selecting this option will dismount and later remount all filesystems on these objects. If any of these filesystems cannot be dismounted, the backup session fails.</p> <p>If an integrated application exclusively controls data I/O on each physical drive, disk, or logical volume that will be backed up, the dismount operation is not needed. In such a case, you can leave this option cleared.</p> <p>Default: not selected.</p>
<p>Stop/quiesce the application command line</p>	<p>If a command is specified in this option, it is invoked on the application system immediately before replica creation. An example is to stop applications not integrated with Data Protector.</p> <p>The command must reside on the application system in the default Data Protector administrative commands directory. Do not specify the path to the command in this option.</p> <p>If the command fails, the command specified in the option Restart the application command line is not invoked. Thus, you may need to implement a cleanup procedure in the command specified in Stop/quiesce the application command line. If the omnirc option ZDB_ALWAYS_POST_SCRIPT is set to 1, the command specified in the option Restart the application command line is always invoked.</p>
<p>Restart the application command line</p>	<p>If a command is specified in this option, it is invoked on the application system immediately after replica creation. An example is to resume operation of applications not integrated with Data</p>

	<p>Protector.</p> <p>The command must reside on the application system in the default Data Protector administrative commands directory. Do not specify the path to the command in this option.</p>
--	--

Backup system options

<p>Use the same mountpoints as on the application system</p>	<p>This option is not available if the application system is also the backup system (a single-host configuration).</p> <p>If this option is selected, the paths to mount points used for mounting the filesystems of the replica on the backup system are the same as paths to mount points where source volume filesystems were mounted on the application system.</p> <p>If the mount points are already in use, the session fails. For such circumstances, you must select the option Automatically dismount the filesystems at destination mountpoints in order for the session to succeed.</p> <p>Windows systems: The drive letters must be available, otherwise the session fails.</p> <p>Default: not selected.</p>
<p>Root of the mount path on the backup system</p>	<p>This option is only available if the option Use the same mountpoints as on the application system is not selected.</p> <p>Specifies the root directory under which the filesystems of the replica are mounted.</p> <p>Where exactly the filesystems are mounted depends on how you define the option Add directories to the mount path.</p> <p>Defaults:</p> <p>Windows systems: c:\mnt</p> <p>UNIX systems: /mnt</p>
<p>Add directories to the mount path</p>	<p>This option is only available if the option Use the same mountpoints as on the application system is not selected.</p> <p>This option enables control over the created mount points. It defines which subdirectories will be created in the directory defined with the Root of the mount path on the backup system option. When Session ID is used in path composition, this guarantees unique mount points.</p> <p>Example for Windows systems:</p> <p>Root directory: C:\mnt</p> <p>Application system: app1sys.company.com</p>

	<p>Backup session ID: 2008-02-22-4</p> <p>Mount path on the application system: E:\disk1</p> <p>If Hostname is selected:</p> <p>C:\mnt\applsys.company.com\E\disk1</p> <p>If Hostname and session ID is selected:</p> <p>C:\mnt\applsys.company.com\2008-02-22-4\E\disk1</p> <p>If Session ID is selected:</p> <p>C:\mnt\2008-02-22-4\E\disk1</p> <p>If Session ID and hostname is selected:</p> <p>C:\mnt\2008-02-22-4\applsys.company.com\E\disk1</p> <p>Default: Hostname and session ID.</p>
<p>Automatically dismount the filesystems at destination mountpoints</p>	<p>If the mount points are in use (for example, volumes involved in the previous session may still be mounted) and this option is selected, Data Protector attempts to dismount the mounted filesystems.</p> <p>If the option is not selected and the mount points are in use, or if the option is selected and the dismount operation fails, the session fails.</p> <p>Default: not selected.</p>
<p>Leave the backup system enabled</p>	<p>This option is only available if the option Keep the replica after the backup is selected.</p> <p>If this option is selected, the filesystems remain mounted, the volume groups remain imported and active (UNIX systems), and the target volumes remain presented after the session. In this case, you can use the backup system for data warehousing purposes. If the replica has to be reused later on (deleted or rotated out), Data Protector automatically connects to the backup system, dismounts the filesystems, unrepresents the target volumes, and clears the related logical structures on the backup system. At that point in time, if the filesystems are not mounted to the current backup system, Data Protector cannot perform a proper cleanup, and aborts the operation).</p> <p>If this option is not selected, Data Protector dismounts filesystems, exports volume groups (UNIX systems), and unrepresents the target volumes on the backup system at the end of the ZDB session.</p>
<p>Enable the backup system in read/write mode</p>	<p>This option is applicable to UNIX systems only. On Windows systems, filesystems cannot be mounted in the read-only mode.</p> <p>Select this option to enable write access to volume groups and filesystems on the backup system. For backup purposes, it is sufficient to activate the backup system volume groups and mount</p>

	<p>the filesystems in the read-only mode. For other tasks, the read/write mode may be needed.</p> <p>Note that when this option is selected, the replica is open to modifications while the backup system is online. Consequently, data restored from such a replica includes all potential modifications.</p> <p>Defaults:</p> <p>Windows systems: selected.</p> <p>UNIX systems: not selected.</p>
--	--

Note: In a ZDB session, the mount points, to which filesystems of the replica are mounted on the backup system, are the same as the mount points to which source volumes were mounted on the application system, if at least one of the following conditions is met:

- The GUI option **Use the same mountpoints as on the application system** is selected.
- The `omnirc` option `ZDB_PRESERVE_MOUNTPOINTS` is set to 1.

If the option **Use the same mountpoints as on the application system** is not selected, and the `omnirc` option `ZDB_PRESERVE_MOUNTPOINTS` is set to 0, the mount points are determined by the GUI options **Root of the mount path on the backup system** and **Add directories to the mount path**, while the `omnirc` options `ZDB_MULTI_MOUNT` and `ZDB_MOUNT_PATH` are ignored.

Chapter 23: Restore

This chapter describes configuring and running a filesystem or disk image restore of the data backed up using the Data Protector NetApp Storage integration.

The data backed up in a ZDB session using NetApp Storage can be stored on backup media only (ZDB to tape).

Data backed up in ZDB-to-tape sessions can be restored from the backup media to the application system. For more information on this restore type, see the *HPE Data Protector Help* index: “restore”.

Tip: You can improve the data transfer rate by connecting a backup device directly to the application system. For information on configuring backup devices, see the *HPE Data Protector Help* index: “backups devices: configuring”. For information on performing a restore using another device, see the *HPE Data Protector Help* index: “selecting, devices for restore”.

Chapter 24: Troubleshooting

Before you begin

This chapter lists general checks and verifications that you may need to perform when you encounter problems with the Data Protector NetApp Storage integration. For general Data Protector troubleshooting information, see the *HPE Data Protector Troubleshooting Guide*.

- Ensure that the latest official Data Protector patches are installed. For information on how to verify this, see the *HPE Data Protector Help* index: “patches”.
- For general Data Protector and integration-specific limitations, as well as recognized issues and workarounds, see the HPE Data Protector Product Announcements, Software Notes, and References.
- For an up-to-date list of supported versions, platforms, and other information, see <https://softwaresupport.hpe.com/>.

Checks and verifications

- On the application and backup systems, examine system errors logged into the `debug.log` file residing in the Data Protector log files directory.

Part 7: EMC VNX Family

This part describes how to configure the Data Protector EMC VNX Family integration, how to perform zero downtime backup using the EMC VNX storage system, and how to resolve the integration-specific Data Protector problems.

Chapter 25: Configuration

Introduction

This chapter describes configuration of the Data Protector EMC VNX Family integration, lists prerequisites and limitations of the integration.

Data Protector EMC VNX Family integration supports VNX Snapshots, which are vsnaps based on redirect-on-write technology. Redirect-on-write enables much better performance compared to copy-on-write technology by writing new data blocks to a new area on the source volume without writing the old data blocks to a another volume first.

To know more about EMC VNX Family disk arrays and VNX Snapshots, see the EMC VNX documentation.

Prerequisites

- Make sure the same operating system version is installed on both the application system and the backup system.
- If the application system and the backup system reside in a Data Protector cell with secured clients, ensure that access between both systems is allowed in both directions.
- Connect your EMC VNX storage system to the application and backup systems through the SAN.
- Make sure source volumes have enough space for snapshots and clones.

EMC VNX licenses and components

- Install `naviseccli` (Navisphere Secure Command Line Utility) on backup client.
- Change security level on backup client to low using the `naviseccli` utility:

```
naviseccli security -certificate -setlevel low
```
- Make sure that the names of storage groups on the EMC VNX storage system are the same as the fully-qualified domain names of the systems they represent.
- Make sure that an appropriate multi-path device management is installed on the application system and the backup system.

Linux systems: HPE Device Mapper Multipath Enablement Kit for HPE Disk Arrays 4.2.0 or newer version.

To configure the installed multi-path device management software:

- a. Start the multipath daemon and run the following command to configure the daemon so that it gets started during system startup:

Red Hat Enterprise Linux: `chkconfig multipathd on`

SUSE Linux Enterprise Server: `chkconfig boot.multipath on`

- b. Prevent the multipath device management software from queuing for unavailable disk volumes by modifying its configuration file. In the `defaults` section of the file `/etc/multipath.conf` file, add the following line:

```
no_path_retry          fail
```

Ensure that this `no_path_retry` parameter value is not overridden by equivalent entries in the device sections of the same file in which the corresponding EMC VNX storage systems are configured.

- c. Ensure that the correct preferred names are used for pathnames that are referencing the same device for physical volumes as they are used in device-mapper multipathing.

Open the `lvm.conf` file, residing in the `/etc/lvm/` directory, and set the following variable:

```
preferred_names = [ "^/dev/mpath/", "^/dev/mapper/mpath", "^/dev/[hs]d" ]
```

Windows systems: Microsoft MPIO configured for EMC VNX Storage Provider. For more information, see the EMC VNX Family documentation.

Data Protector licenses and components:

- An appropriate zero downtime backup extension for non-HPE Storage Arrays licenses-to-use (LTU).
- The EMC VNX Storage Provider component installed on both the application system and the backup system.

For licensing information and installation and upgrade instructions, see the *HPE Data Protector Installation Guide*.

Prerequisites for Windows systems

- On Windows Server 2003 and Windows Server 2008 systems, disable the operating system option **Automatic mounting of new volumes**. In the Command Prompt window, run the command `mountvol /N`.
- Do not manually mount target volumes that were created by Data Protector.

Limitations

- In cluster environments, the backup system must not be in the same cluster with the application system. Additionally, the backup system cannot be the cluster virtual server, it can only be a cluster node.
- Instant recovery is not supported.
- SnapView Snapshot is not supported.

For information on the following items, see the HPE Data Protector Product Announcements, Software Notes, and References:

- General Data Protector and integration-specific limitations
- Supported platforms and integrations
- Supported backup and connectivity topologies

ZDB database - SMISDB

ZDB database for the Data Protector EMC VNX Family integration is referred to as SMISDB. It keeps information about EMC VNX storage systems. For each system, the following is stored:

- Hostname as recognized in the IP network.
- User name and encoded password for the EMC VNX Storage Provider login

SMISDB resides on the Cell Manager in:

Windows systems: `Data_Protector_program_data\server\db80\smisdb`

UNIX systems: `/var/opt/omni/server/db80/smisdb`

Configuring the integration

Before you start with the configuration, make sure the prerequisites listed in "Introduction" are fulfilled.

To integrate with the EMC VNX storage system, Data Protector uses the EMC VNX Storage Provider. This plug-in enables EMC VNX storage support within the Data Protector ZDB (SMI-S) agent. To configure the Data Protector EMC VNX Family integration, provide the data that the Data Protector ZDB agent will use to establish connection to an EMC VNX storage system of your choice.

The connection configuration data includes user credentials that you must add to the ZDB database (the EMC VNX part of SMISDB). The credentials are bound to a specific application system in the Data Protector cell. The Data Protector ZDB agent then reads the credentials from the ZDB database each time a zero downtime backup for data residing on an EMC VNX storage system is started.

Connection configuration data

To be able to connect to an EMC VNX storage system and perform zero downtime backup, the Data Protector ZDB agent needs the following information:

- Fully qualified domain name or IP address of the system where the EMC VNX Storage Provider resides
If the system has multiple IP addresses, use the address by which the Data Protector ZDB agent can access the system.
- Username and password
These credentials must belong to the EMC VNX storage system Administrator account. For more information on using the EMC VNX storage authorization system and on EMC VNX user groups, see the EMC VNX Family documentation.

You need to provide the above information to enable connection between the Data Protector ZDB agent and the EMC VNX storage system. It is stored in the EMC VNX part of the SMISDB.

Configuration procedure

To establish connection to the EMC VNX storage system, use the Data Protector `omnidbzdb` command. Follow the steps:

1. Select the EMC VNX storage system user account that has a proper privilege level on the corresponding domains. Identify and write down its username and password, which you will need in the next step.
2. Use the `omnidbzdb` command to establish connection to the EMC VNX storage system and to add the username and password that you acquired in the previous step to the ZDB database. Run the following command:

```
omnidbzd --diskarray ArrayFamily --ompasswd --add ClientName --user UserName -  
-passwd password
```

where:

ArrayFamily - EMCVNX

ClientName - fully qualified domain name or an IP address of the EMC VNX storage system

UserName and *password* - user credentials that you acquired in the previous step

For example:

```
omnidbzd --diskarray EMCVNX --ompasswd --add vnxstorage.company.com --user  
vnxadmin --passwd pwd
```

For command syntax and usage examples, see the `omnidbzd` reference page in the *HPE Data Protector Command Line Interface Reference* or the `omnidbzd` man page.

3. Using the `omnidbzd --diskarray EMCVNX --ompasswd --check` command, verify that the Data Protector EMC VNX Storage Provider can connect to the EMC VNX storage system using the configured user authentication data.

Tip: For each application system, you can add user credentials of multiple EMC VNX user accounts. When several are configured for the same system, the Data Protector ZDB agent checks user accounts in alphabetical order and uses the first account with *Edit* privilege level on the application system and the source volumes.

For information on performing other tasks related to management of user credentials in the ZDB database, see the `omnidbzd` reference page in the *HPE Data Protector Command Line Interface Reference* or the `omnidbzd` man page.

Chapter 26: Backup

This chapter describes configuration of a filesystem and disk image ZDB using the Data Protector GUI.

With the EMC VNX Storage Provider integration, you can perform the backup of the ZDB to tape type only. For more information on the ZDB types, see the *HPE Data Protector Concepts Guide*.

You should be familiar with the EMC VNX storage concepts and basic Data Protector ZDB functionality. See the EMC VNX Family storage-related documentation and the *HPE Data Protector Concepts Guide*.

For information on the supported configurations, ZDB types and replication techniques available on this storage system, and storage system-specific ZDB considerations, see the *HPE Data Protector Concepts Guide*.

Creating backup specification

Limitations

- The only supported ZDB type is ZDB to tape.
- Only one snapshot type for target volumes can be created during a ZDB session.
- When cloning process for a source volume is in progress, another snapshot (any type) of that source volume cannot be created.
- You cannot back up replicas (target volumes from existing and currently recorded backup sessions).
- If there is not enough space for a fully allocated replica creation, the session fails.

Considerations

- Consider all limitations that apply to the Data Protector EMC VNX Family integration. See the HPE Data Protector Product Announcements, Software Notes, and References, the *HPE Data Protector Concepts Guide*, and the limitation list in "[Configuration](#)".

Procedure

To create a ZDB backup specification for an EMC VNX storage using the Data Protector GUI (Data Protector Manager), follow the steps:

1. In the Context List, select **Backup**.
2. In the Scoping Pane, expand **Backup Specifications**. Right-click **Filesystem** (for both object types: filesystem and disk image) and click **Add Backup**.

The Create New Backup dialog box appears.

In the Filesystem pane, select the **Blank Filesystem Backup** template or some other available template. For information on templates, see the *HPE Data Protector Help* index: "backup templates".

Select **Snapshot or split mirror backup** as Backup type and **Storage Provider(s) Plugin** as Sub type. For description of options, press **F1**.

Click **OK**.

- Under Client systems, select **Application system** and **Backup system**. If the application system is part of a server cluster, select the virtual server.
- Under Add Storage Provider, select **EMC VNX Storage Provider** from the Storage provider drop-down list and then click **Add**. The EMC VNX Storage Provider Options dialog opens. Enter the path to the `naviseccli` utility. From the Replica Type drop-down list, select **VNX Snapshot**, enter a replica description, and click **OK**. The EMC VNX storage is added to a list. You can later change its options by clicking **Edit** or remove it from the list by clicking **Remove**. For more information, press **F1**.

EMC VNX zero downtime backup options

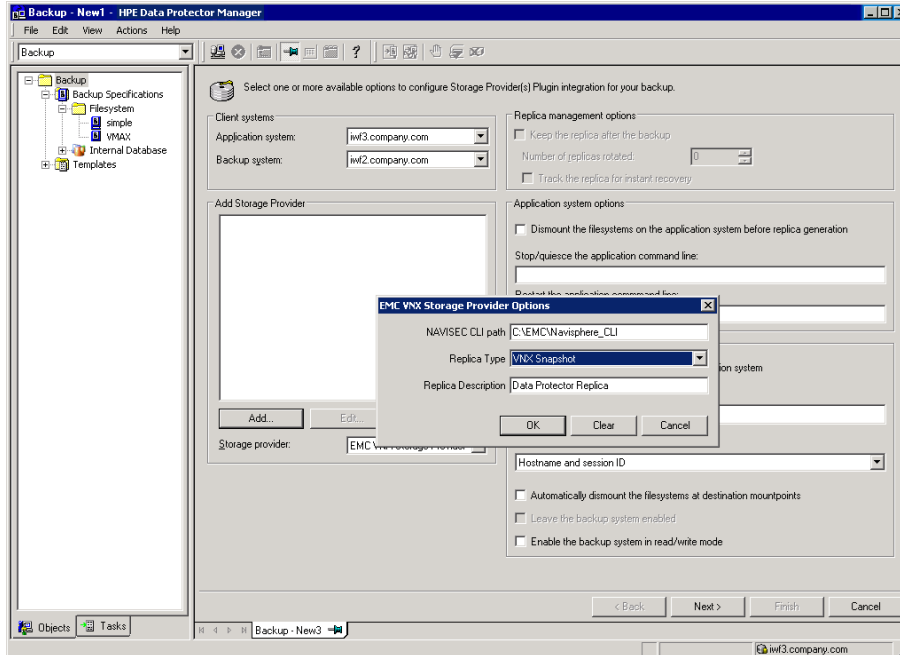

- Under Application system options and Backup system options, specify other zero downtime backup options as required. For information, press **F1**.
Click **Next**.
- Select the objects for backup.
 - Filesystem backup:** Expand the application system and select the objects to back up. Note that all drive letters or mount points that reside on the system are displayed. Select only the objects that reside on the EMC VNX storage system, otherwise the ZDB session fails. Click **Next**.
 - Disk image backup:** Click **Next**.
- Select the devices to use in the backup session.
To create additional copies (mirrors) of the backup image, specify the number of mirrors by clicking **Add mirror** or **Remove mirror**. Select separate devices for the backup image and each mirror.
For information on object mirroring, see the *HPE Data Protector Help* index: "object mirroring".
Click **Next**.
- In the Backup Specification Options group box, click **Advanced** and then the **Storage Provider**

tab to open the options pane with EMC VNX specific backup options.

You can specify Application system options and modify all other options, except **Application system** and **Backup system** (note that you can change them after you save the ZDB backup specification).

Click **Next**.

- Schedule the ZDB sessions. For more information, press **F1**.

Click **Next**.

- In the Backup Object Summary page, specify additional options.
 - Filesystem backup:** To modify options for the listed objects, right-click an object and then click **Properties**. For information on the object properties, press **F1**.
 - Disk image backup:** Follow the steps:
 - Click **Manual add** to add disk image objects.
 - Select **Disk image object** and click **Next**.
 - Select the client system. Optionally, enter the description for your object. Click **Next**.
 - Specify General Object Options and Advanced Object Options. For information on these options, press **F1**.
 - In the Disk Image Object Options window, specify disk image or raw logical volume sections.
Specify a disk image section:
`/dev/rdisk/FileName`, for example: `/dev/rdisk/c2t0d0`
Specify a raw logical volume section:
`/dev/vgnumber/r1volNumber`, for example: `/dev/vg01/r1vol1`
 - Click **Finish**.

Click **Next**.

- Save your ZDB backup specification.

Backup options

The following tables describe the ZDB-related backup options that you can modify when configuring ZDB backup specifications that include storage systems of the EMC VNX Family.

Client systems

Application system	The system on which the application runs. In cluster environments, specify the virtual server hostname (rather than the physical node hostname).
Backup system	The system to which your data will be replicated (backed up), and from which the backup data is copied to a backup device.

EMC VNX storage replica type options

<p>VNX Snapshot</p>	<p>VNX Snapshots are thin provisioned, which means that more storage on a LUN is provisioned than is currently available on the volume. This allows you to present more storage space to the backup system connected to the storage than is actually available.</p>
----------------------------	---

Application system options

<p>Dismount the filesystems on the application system before replica generation</p>	<p>Select this option to dismount the filesystems on the application system before replica creation and remount them afterwards. Additionally, when entire physical drives (on Windows systems) or entire disks or logical volumes (on UNIX systems) are selected as backup objects in a disk image backup specification, selecting this option will dismount and later remount all filesystems on these objects. If any of these filesystems cannot be dismounted, the backup session fails.</p> <p>If an integrated application exclusively controls data I/O on each physical drive, disk, or logical volume that will be backed up, the dismount operation is not needed. In such a case, you can leave this option cleared.</p> <p>Default: not selected.</p>
<p>Stop/quiesce the application command line</p>	<p>If a command is specified in this option, it is invoked on the application system immediately before replica creation. An example is to stop applications not integrated with Data Protector.</p> <p>The command must reside on the application system in the default Data Protector administrative commands directory. Do not specify the path to the command in this option.</p> <p>If the command fails, the command specified in the option Restart the application command line is not invoked. Thus, you may need to implement a cleanup procedure in the command specified in Stop/quiesce the application command line. If the <code>omnirc</code> option <code>ZDB_ALWAYS_POST_SCRIPT</code> is set to 1, the command specified in the option Restart the application command line is always invoked.</p>
<p>Restart the application command line</p>	<p>If a command is specified in this option, it is invoked on the application system immediately after replica creation. An example is to resume operation of applications not integrated with Data Protector.</p> <p>The command must reside on the application system in the default Data Protector administrative commands directory. Do not specify the path to the command in this option.</p>

Backup system options

<p>Use the same mountpoints as on the</p>	<p>This option is not available if the application system is also the backup system (a single-host configuration).</p>
--	--

<p>application system</p>	<p>If this option is selected, the paths to mount points used for mounting the filesystems of the replica on the backup system are the same as paths to mount points where source volume filesystems were mounted on the application system.</p> <p>If the mount points are already in use, the session fails. For such circumstances, you must select the option Automatically dismount the filesystems at destination mountpoints in order for the session to succeed.</p> <p>Windows systems: The drive letters must be available, otherwise the session fails.</p> <p>Default: not selected.</p>
<p>Root of the mount path on the backup system</p>	<p>This option is only available if the option Use the same mountpoints as on the application system is not selected.</p> <p>Specifies the root directory under which the filesystems of the replica are mounted.</p> <p>Where exactly the filesystems are mounted depends on how you define the option Add directories to the mount path.</p> <p>Defaults:</p> <p>Windows systems: c:\mnt</p> <p>UNIX systems: /mnt</p>
<p>Add directories to the mount path</p>	<p>This option is only available if the option Use the same mountpoints as on the application system is not selected.</p> <p>This option enables control over the created mount points. It defines which subdirectories will be created in the directory defined with the Root of the mount path on the backup system option. When Session ID is used in path composition, this guarantees unique mount points.</p> <p>Example for Windows systems:</p> <p>Root directory: C:\mnt</p> <p>Application system: applsys.company.com</p> <p>Backup session ID: 2008-02-22-4</p> <p>Mount path on the application system: E:\disk1</p> <p>If Hostname is selected:</p> <p>C:\mnt\applsys.company.com\E\disk1</p> <p>If Hostname and session ID is selected:</p> <p>C:\mnt\applsys.company.com\2008-02-22-4\E\disk1</p> <p>If Session ID is selected:</p>

	<p>C:\mnt\2008-02-22-4\E\disk1</p> <p>If Session ID and hostname is selected:</p> <p>C:\mnt\2008-02-22-4\applsyst.companys.com\E\disk1</p> <p>Default: Hostname and session ID.</p>
<p>Automatically dismount the filesystems at destination mountpoints</p>	<p>If the mount points are in use (for example, volumes involved in the previous session may still be mounted) and this option is selected, Data Protector attempts to dismount the mounted filesystems.</p> <p>If the option is not selected and the mount points are in use, or if the option is selected and the dismount operation fails, the session fails.</p> <p>Default: not selected.</p>
<p>Leave the backup system enabled</p>	<p>This option is only available if the option Keep the replica after the backup is selected.</p> <p>If this option is selected, the filesystems remain mounted, the volume groups remain imported and active (UNIX systems), and the target volumes remain presented after the session. In this case, you can use the backup system for data warehousing purposes. If the replica has to be reused later on (deleted or rotated out), Data Protector automatically connects to the backup system, dismounts the filesystems, unrepresents the target volumes, and clears the related logical structures on the backup system. At that point in time, if the filesystems are not mounted to the current backup system, Data Protector cannot perform a proper cleanup, and aborts the operation).</p> <p>If this option is not selected, Data Protector dismounts filesystems, exports volume groups (UNIX systems), and unrepresents the target volumes on the backup system at the end of the ZDB session.</p>
<p>Enable the backup system in read/write mode</p>	<p>This option is applicable to UNIX systems only. On Windows systems, filesystems cannot be mounted in the read-only mode.</p> <p>Select this option to enable write access to volume groups and filesystems on the backup system. For backup purposes, it is sufficient to activate the backup system volume groups and mount the filesystems in the read-only mode. For other tasks, the read/write mode may be needed.</p> <p>Note that when this option is selected, the replica is open to modifications while the backup system is online. Consequently, data restored from such a replica includes all potential modifications.</p> <p>Defaults:</p> <p>Windows systems: selected.</p> <p>UNIX systems: not selected.</p>

Note: In a ZDB session, the mount points, to which filesystems of the replica are mounted on the backup system, are the same as the mount points to which source volumes were mounted on the application system, if at least one of the following conditions is met:

- The GUI option **Use the same mountpoints as on the application system** is selected.
- The `omnirc` option `ZDB_PRESERVE_MOUNTPOINTS` is set to 1.

If the option **Use the same mountpoints as on the application system** is not selected, and the `omnirc` option `ZDB_PRESERVE_MOUNTPOINTS` is set to 0, the mount points are determined by the GUI options **Root of the mount path on the backup system** and **Add directories to the mount path**, while the `omnirc` options `ZDB_MULTI_MOUNT` and `ZDB_MOUNT_PATH` are ignored.

Chapter 27: Restore

This chapter describes configuring and running a filesystem or disk image restore of the data backed up using the Data Protector EMC VNX Family integration.

The data backed up in a ZDB session using EMC VNX storage can be stored on backup media only (ZDB to tape).

Data backed up in ZDB-to-tape sessions can be restored from the backup media to the application system. For more information on this restore type, see the *HPE Data Protector Help* index: "restore".

Tip: You can improve the data transfer rate by connecting a backup device directly to the application system. For information on configuring backup devices, see the *HPE Data Protector Help* index: "backups devices: configuring". For information on performing a restore using another device, see the *HPE Data Protector Help* index: "selecting, devices for restore".

Chapter 28: Troubleshooting

Before you begin

This chapter lists general checks and verifications that you may need to perform when you encounter problems with the Data Protector EMC VNX Family integration. For general Data Protector troubleshooting information, see the *HPE Data Protector Troubleshooting Guide*.

- Ensure that the latest official Data Protector patches are installed. For information on how to verify this, see the *HPE Data Protector Help* index: “patches”.
- For general Data Protector and integration-specific limitations, as well as recognized issues and workarounds, see the HPE Data Protector Product Announcements, Software Notes, and References.
- For an up-to-date list of supported versions, platforms, and other information, see <https://softwaresupport.hpe.com/>.

Checks and verifications

- On the application and backup systems, examine system errors logged into the debug.log file residing in the Data Protector log files directory.

Part 8: EMC VMAX Family

This part describes how to configure the Data Protector EMC VMAX Family integration, how to perform zero downtime backup using the EMC VMAX storage system, and how to resolve the integration-specific Data Protector problems.

Chapter 29: Configuration

Introduction

This chapter describes configuration of the Data Protector EMC VMAX Family integration, lists prerequisites and limitations of the integration.

Data Protector EMC VMAX Family integration supports TimeFinder/Clone and TimeFinder VP Snap types. From the perspective of Data Protector, both EMC VMAX snapshot types are vsnaps.

To know more about EMC VMAX Family disk arrays and supported snapshot types, see the EMC VMAX documentation.

Prerequisites

- Make sure the same operating system version is installed on both the application system and the backup system.
- If the application system and the backup system reside in a Data Protector cell with secured clients, ensure that access between both systems is allowed in both directions.
- Connect your EMC VMAX storage system to the application and backup systems through the SAN.
- Make sure source volumes have enough space for snapshots and clones.
- Make sure that the names of storage groups on the EMC VMAX storage system are the same as the fully-qualified domain names of the systems they represent, while having the dots replaced with underscores.
- Make sure the omnirc options on both the application and the backup clients are set to:

```
LD_LIBRARY_PATH=/usr/lib/hpux64
```

```
SHLIB_PATH=/usr/lib/hpux64
```

```
DYNAMIC_PATH=/usr/lib/hpux64
```

```
LIBPATH=/usr/lib/hpux64
```

EMC VMAX licenses and components

- Install the EMC Solution Enabler. The `symcli` command interface is also installed along.
- EMC TimeFinder microcode and license
- Make sure that an appropriate multi-path device management is installed on the application system and the backup system.

Linux systems: HPE Device Mapper Multipath Enablement Kit for HPE Disk Arrays 4.2.0 or newer version.

To configure the installed multi-path device management software:

- a. Start the multipath daemon and run the following command to configure the daemon so that it gets started during system startup:

Red Hat Enterprise Linux: `chkconfig multipathd on`

SUSE Linux Enterprise Server: `chkconfig boot.multipath on`

- b. Prevent the multipath device management software from queuing for unavailable disk volumes by modifying its configuration file. In the `defaults` section of the file `/etc/multipath.conf` file, add the following line:

```
no_path_retry          fail
```

Ensure that this `no_path_retry` parameter value is not overridden by equivalent entries in the device sections of the same file in which the corresponding EMC VMAX storage systems are configured.

- c. Ensure that the correct preferred names are used for pathnames that are referencing the same device for physical volumes as they are used in device-mapper multipathing.

Open the `lvm.conf` file, residing in the `/etc/lvm/` directory, and set the following variable:

```
preferred_names = [ "^/dev/mpath/", "^/dev/mapper/mpath", "^/dev/[hs]d" ]
```

Windows systems: Microsoft MPIO configured for EMC VMAX Storage Provider. For more information, see the EMC VMAX Family documentation.

Data Protector licenses and components:

- An appropriate zero downtime backup extension for non-HPE Storage Arrays licenses-to-use (LTU).
- The EMC VMAX Storage Provider component installed on both the application system and the backup system.
- EMC VMAX plugin

For licensing information and installation and upgrade instructions, see the *HPE Data Protector Installation Guide*.

Prerequisites for Windows systems

- On Windows Server 2003 and Windows Server 2008 systems, disable the operating system option **Automatic mounting of new volumes**. In the Command Prompt window, run the command `mountvol /N`.
- Do not manually mount target volumes that were created by Data Protector.

Limitations

- In cluster environments, the backup system must not be in the same cluster with the application system. Additionally, the backup system cannot be the cluster virtual server, it can only be a cluster node.
- Instant recovery is not supported.
- TimeFinder/Snap snapshot type is not supported.
- TimeFinder/Consistency Groups are not supported.

For information on the following items, see the HPE Data Protector Product Announcements, Software Notes, and References:

- General Data Protector and integration-specific limitations
- Supported platforms and integrations
- Supported backup and connectivity topologies

ZDB database - SMISDB

ZDB database for the Data Protector EMC VMAX Family integration is referred to as SMISDB. It keeps information about EMC VMAX storage systems. For each system, the following is stored:

- Hostname as recognized in the IP network.
- User name and encoded password for the EMC VMAX Storage Provider login

SMISDB resides on the Cell Manager in:

Windows systems: `Data_Protector_program_data\server\db80\smisdb`

UNIX systems: `/var/opt/omni/server/db80/smisdb`

Configuring the integration

Before you start with the configuration, make sure the prerequisites listed in "[Introduction](#)" are fulfilled.

To integrate with the EMC VMAX storage system, Data Protector uses the EMC VMAX Storage Provider. This plug-in enables EMC VMAX storage support within the Data Protector ZDB (SMI-S) agent. To configure the Data Protector EMC VMAX Family integration, provide the data that the Data Protector ZDB agent will use to establish connection to an EMC VMAX storage system of your choice.

The connection configuration data includes user credentials that you must add to the ZDB database (the EMC VMAX part of SMISDB). The credentials are bound to a specific application system in the Data Protector cell. The Data Protector ZDB agent then reads the credentials from the ZDB database each time a zero downtime backup for data residing on an EMC VMAX storage system is started.

Connection configuration data

To be able to connect to an EMC VMAX storage system and perform zero downtime backup, the Data Protector ZDB agent needs the following information:

- Fully qualified domain name or IP address of the system where the EMC VMAX Storage Provider resides
If the system has multiple IP addresses, use the address by which the Data Protector ZDB agent can access the system.
- Username and password
These credentials must belong to the EMC VMAX storage system Administrator account. For more information on using the EMC VMAX storage authorization system and on EMC VMAX user groups, see the EMC VMAX Family documentation.

You need to provide the above information to enable connection between the Data Protector ZDB agent and the EMC VMAX storage system. It is stored in the EMC VMAX part of the SMISDB.

Configuration procedure

To establish connection to the EMC VMAX storage system, use the Data Protector `omnidbzd` command. Follow the steps:

1. Select the EMC VMAX storage system user account that has a proper privilege level on the corresponding domains. Identify and write down its username and password, which you will need in the next step.
2. Use the `omnidbzd` command to establish connection to the EMC VMAX storage system and to add the username and password that you acquired in the previous step to the ZDB database. Run the following command:

```
omnidbzd --diskarray ArrayFamily --ompasswd --add ClientName --user UserName -  
-passwd password
```

where:

ArrayFamily - EMCVMAX

ClientName - fully qualified domain name or an IP address of the EMC VMAX storage system

UserName and *password* - user credentials that you acquired in the previous step

For example:

```
omnidbzd --diskarray EMCVMAX --ompasswd --add vmaxstorage.company.com --user  
vmaxadmin --passwd pwd
```

For command syntax and usage examples, see the `omnidbzd` reference page in the *HPE Data Protector Command Line Interface Reference* or the `omnidbzd` man page.

3. Using the `omnidbzd --diskarray EMCVMAX --ompasswd --check` command, verify that the Data Protector EMC VMAX Storage Provider can connect to the EMC VMAX storage system using the configured user authentication data.

Tip: For each application system, you can add user credentials of multiple EMC VMAX user accounts. When several are configured for the same system, the Data Protector ZDB agent checks user accounts in alphabetical order and uses the first account with *Edit* privilege level on the application system and the source volumes.

For information on performing other tasks related to management of user credentials in the ZDB database, see the `omnidbzd` reference page in the *HPE Data Protector Command Line Interface Reference* or the `omnidbzd` man page.

Chapter 30: Backup

This chapter describes configuration of a filesystem or disk image ZDB using the Data Protector GUI.

With the EMC VMAX Storage Provider integration, you can perform the backup of the ZDB to tape type only. For more information on the ZDB types, see the *HPE Data Protector Concepts Guide*.

You should be familiar with the EMC VMAX storage concepts and basic Data Protector ZDB functionality. See the EMC VMAX Family storage-related documentation and the *HPE Data Protector Concepts Guide*.

For information on the supported configurations, ZDB types and replication techniques available on this storage system, and storage system-specific ZDB considerations, see the *HPE Data Protector Concepts Guide*.

Backup concepts

EMC VMAX backup consists of two phases:

1. Application system data gets synchronized to the backup system.
During this phase, the synchronization is performed on the level of participating volume groups or disks. Therefore, if multiple filesystems/disk images are configured in the same volume group or on the same disk, the *whole* volume group or disk (all filesystems or disk images in this volume group or on disk) is synchronized to the backup system regardless of the objects selected for backup.
2. Synchronized backup system data is backed up to a backup device.
During this phase, only the objects selected for backup are backed up.

Creating backup specification

Limitations

- The only supported ZDB type is ZDB to tape.
- Only one snapshot type for target volumes can be created during a ZDB session.
- When cloning process for a source volume is in progress, another snapshot (any type) of that source volume cannot be created.
- You cannot back up replicas (target volumes from existing and currently recorded backup sessions).
- If there is not enough space for a fully allocated replica creation, the session fails.

Considerations

- Consider all limitations that apply to the Data Protector EMC VMAX Family integration. See the HPE Data Protector Product Announcements, Software Notes, and References, the *HPE Data Protector Concepts Guide*, and the limitation list in "[Configuration](#)".

Procedure

To create a ZDB backup specification for an EMC VMAX storage using the Data Protector GUI (Data Protector Manager), follow the steps:

1. In the Context List, select **Backup**.
2. In the Scoping Pane, expand **Backup Specifications**. Right-click **Filesystem** (for both object types: filesystem and disk image) and click **Add Backup**.

The Create New Backup dialog box appears.

In the Filesystem pane, select the **Blank Filesystem Backup** template or some other available template. For information on templates, see the *HPE Data Protector Help* index: "backup templates".

Select **Snapshot or split mirror backup** as Backup type and **Storage Provider(s) Plugin** as Sub type. For description of options, press **F1**.

Click **OK**.

3. Under Client systems, select **Application system** and **Backup system**. If the application system is part of a server cluster, select the virtual server.
4. Under Add Storage Provider, select **EMC VMAX Storage Provider** from the Storage provider drop-down list and then click **Add**. The EMC VMAX Storage Provider Options dialog opens. Enter the **SYMCLI binaries path** and select **Local** as the Connection type. In the Target Pool, enter the pool in which the replica will be created. From the Replica Type drop-down list, select **Clone** or **Snapshot**, enter a Replica Description, and click **OK**. The EMC VMAX storage is added to a list. You can later change its options by clicking **Edit** or remove it from the list by clicking **Remove**. For more information, press **F1**.

EMC VMAX zero downtime backup options

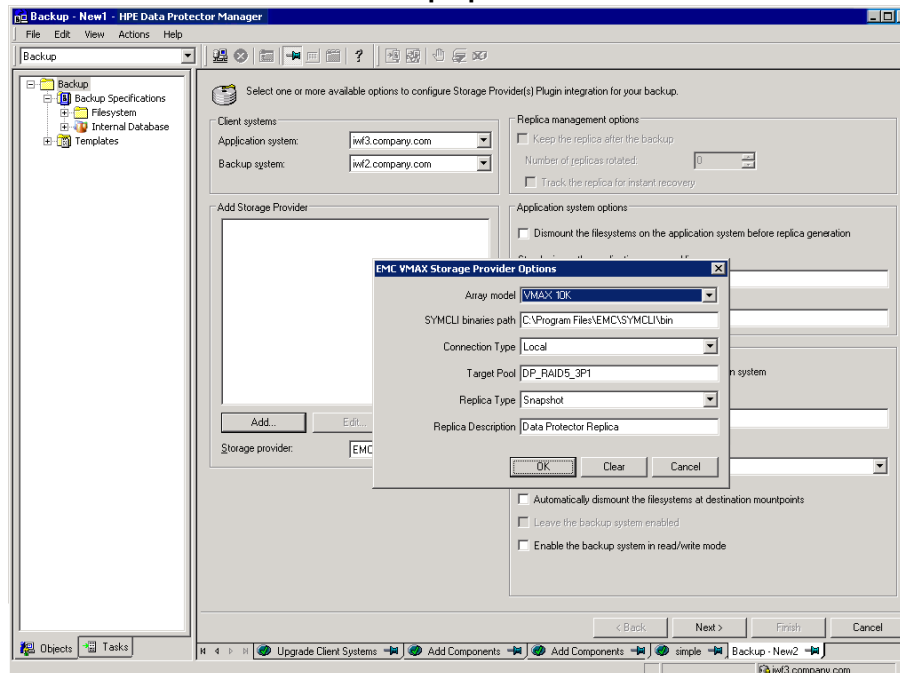

5. Under Application system options and Backup system options, specify other zero downtime backup options as required. For information, see "[Backup options](#)" or press **F1**.

Click **Next**.

6. Select the objects for backup.
 - **Filesystem backup:** Expand the application system and select the objects to back up. Note that all drive letters or mount points that reside on the system are displayed. Select only the objects that reside on the EMC VMAX storage system, otherwise the ZDB session fails. Click **Next**.

- **Disk image backup:** Click **Next**.

7. Select the devices to use in the backup session.

To create additional copies (mirrors) of the backup image, specify the number of mirrors by clicking **Add mirror** or **Remove mirror**. Select separate devices for the backup image and each mirror.

For information on object mirroring, see the *HPE Data Protector Help* index: "object mirroring".

Click **Next**.

8. In the Backup Specification Options group box, click **Advanced** and then the **Storage Provider** tab to open the options pane with EMC VMAX specific backup options.

You can specify Application system options and modify all other options, except **Application system** and **Backup system**.

Click **Next**.

9. Schedule the ZDB sessions. For more information, press **F1**.

Click **Next**.

10. In the Backup Object Summary page, specify additional options.

- **Filesystem backup:** To modify options for the listed objects, right-click an object and then click **Properties**. For information on the object properties, press **F1**.
- **Disk image backup:** Follow the steps:
 - i. Click **Manual add** to add disk image objects.
 - ii. Select **Disk image object** and click **Next**.
 - iii. Select the client system. Optionally, enter the description for your object. Click **Next**.
 - iv. Specify General Object Options and Advanced Object Options. For information on these options, press **F1**.
 - v. In the Disk Image Object Options window, specify disk image or raw logical volume sections.

Specify a disk image section:
`/dev/rdisk/FileName`, for example: `/dev/rdisk/c2t0d0`

Specify a raw logical volume section:
`/dev/vgnumber/r1volNumber`, for example: `/dev/vg01/r1vol1`
 - vi. Click **Finish**.

Click **Next**.

11. Save your ZDB backup specification.

Backup options

The following tables describe the ZDB-related backup options that you can modify when configuring ZDB backup specifications that include storage systems of the EMC VMAX Family.

Client systems

Application system	The system on which the application runs. In cluster environments, specify the virtual server hostname (rather than the physical node hostname).
Backup system	The system to which your data will be replicated (backed up), and from which the backup data is copied to a backup device.

EMC VMAX storage replica type options

Clone	TimeFinder/Clone. Local point-in-time copy of a VMAX device, allows up to 16 active clones of a single device.
Snapshot	TimeFinder VP Snap. Creates a snap for Virtual Pool devices and allows up to 32 VP snaps per source volume to be created.

Application system options

Dismount the filesystems on the application system before replica generation	<p>Select this option to dismount the filesystems on the application system before replica creation and remount them afterwards. Additionally, when entire physical drives (on Windows systems) or entire disks or logical volumes (on UNIX systems) are selected as backup objects in a disk image backup specification, selecting this option will dismount and later remount all filesystems on these objects. If any of these filesystems cannot be dismounted, the backup session fails.</p> <p>If an integrated application exclusively controls data I/O on each physical drive, disk, or logical volume that will be backed up, the dismount operation is not needed. In such a case, you can leave this option cleared.</p> <p>Default: not selected.</p>
Stop/quiesce the application command line	<p>If a command is specified in this option, it is invoked on the application system immediately before replica creation. An example is to stop applications not integrated with Data Protector.</p> <p>The command must reside on the application system in the default Data Protector administrative commands directory. Do not specify the path to the command in this option.</p> <p>If the command fails, the command specified in the option Restart</p>

	<p>the application command line is not invoked. Thus, you may need to implement a cleanup procedure in the command specified in Stop/quiesce the application command line. If the <code>omnirc</code> option <code>ZDB_ALWAYS_POST_SCRIPT</code> is set to 1, the command specified in the option Restart the application command line is always invoked.</p>
<p>Restart the application command line</p>	<p>If a command is specified in this option, it is invoked on the application system immediately after replica creation. An example is to resume operation of applications not integrated with Data Protector.</p> <p>The command must reside on the application system in the default Data Protector administrative commands directory. Do not specify the path to the command in this option.</p>

Backup system options

<p>Use the same mountpoints as on the application system</p>	<p>This option is not available if the application system is also the backup system (a single-host configuration).</p> <p>If this option is selected, the paths to mount points used for mounting the filesystems of the replica on the backup system are the same as paths to mount points where source volume filesystems were mounted on the application system.</p> <p>If the mount points are already in use, the session fails. For such circumstances, you must select the option Automatically dismount the filesystems at destination mountpoints in order for the session to succeed.</p> <p>Windows systems: The drive letters must be available, otherwise the session fails.</p> <p>Default: not selected.</p>
<p>Root of the mount path on the backup system</p>	<p>This option is only available if the option Use the same mountpoints as on the application system is not selected.</p> <p>Specifies the root directory under which the filesystems of the replica are mounted.</p> <p>Where exactly the filesystems are mounted depends on how you define the option Add directories to the mount path.</p> <p>Defaults:</p> <p>Windows systems: <code>c:\mnt</code></p> <p>UNIX systems: <code>/mnt</code></p>
<p>Add directories to the mount path</p>	<p>This option is only available if the option Use the same mountpoints as on the application system is not selected.</p> <p>This option enables control over the created mount points. It defines</p>

	<p>which subdirectories will be created in the directory defined with the Root of the mount path on the backup system option. When Session ID is used in path composition, this guarantees unique mount points.</p> <p>Example for Windows systems:</p> <p>Root directory: C:\mnt</p> <p>Application system: applsys.company.com</p> <p>Backup session ID: 2008-02-22-4</p> <p>Mount path on the application system: E:\disk1</p> <p>If Hostname is selected:</p> <p>C:\mnt\applsys.company.com\E\disk1</p> <p>If Hostname and session ID is selected:</p> <p>C:\mnt\applsys.company.com\2008-02-22-4\E\disk1</p> <p>If Session ID is selected:</p> <p>C:\mnt\2008-02-22-4\E\disk1</p> <p>If Session ID and hostname is selected:</p> <p>C:\mnt\2008-02-22-4\applsys.company.com\E\disk1</p> <p>Default: Hostname and session ID.</p>
<p>Automatically dismount the filesystems at destination mountpoints</p>	<p>If the mount points are in use (for example, volumes involved in the previous session may still be mounted) and this option is selected, Data Protector attempts to dismount the mounted filesystems.</p> <p>If the option is not selected and the mount points are in use, or if the option is selected and the dismount operation fails, the session fails.</p> <p>Default: not selected.</p>
<p>Leave the backup system enabled</p>	<p>This option is only available if the option Keep the replica after the backup is selected.</p> <p>If this option is selected, the filesystems remain mounted, the volume groups remain imported and active (UNIX systems), and the target volumes remain presented after the session. In this case, you can use the backup system for data warehousing purposes. If the replica has to be reused later on (deleted or rotated out), Data Protector automatically connects to the backup system, dismounts the filesystems, unpresents the target volumes, and clears the related logical structures on the backup system. At that point in time, if the filesystems are not mounted to the current backup system, Data Protector cannot perform a proper cleanup, and aborts the operation).</p> <p>If this option is not selected, Data Protector dismounts filesystems,</p>

	<p>exports volume groups (UNIX systems), and unrepresents the target volumes on the backup system at the end of the ZDB session.</p>
<p>Enable the backup system in read/write mode</p>	<p>This option is applicable to UNIX systems only. On Windows systems, filesystems cannot be mounted in the read-only mode.</p> <p>Select this option to enable write access to volume groups and filesystems on the backup system. For backup purposes, it is sufficient to activate the backup system volume groups and mount the filesystems in the read-only mode. For other tasks, the read/write mode may be needed.</p> <p>Note that when this option is selected, the replica is open to modifications while the backup system is online. Consequently, data restored from such a replica includes all potential modifications.</p> <p>Defaults:</p> <p>Windows systems: selected.</p> <p>UNIX systems: not selected.</p>

Note: In a ZDB session, the mount points, to which filesystems of the replica are mounted on the backup system, are the same as the mount points to which source volumes were mounted on the application system, if at least one of the following conditions is met:

- The GUI option **Use the same mountpoints as on the application system** is selected.
- The `omnirc` option `ZDB_PRESERVE_MOUNTPOINTS` is set to 1.

If the option **Use the same mountpoints as on the application system** is not selected, and the `omnirc` option `ZDB_PRESERVE_MOUNTPOINTS` is set to 0, the mount points are determined by the GUI options **Root of the mount path on the backup system** and **Add directories to the mount path**, while the `omnirc` options `ZDB_MULTI_MOUNT` and `ZDB_MOUNT_PATH` are ignored.

Chapter 31: Restore

This chapter describes configuring and running a filesystem or disk image restore of the data backed up using the Data Protector EMC VMAX Family integration.

The data backed up in a ZDB session using EMC VMAX storage can be stored on backup media only (ZDB to tape).

Data backed up in ZDB-to-tape sessions can be restored from the backup media to the application system. For more information on this restore type, see the *HPE Data Protector Help* index: "restore".

Tip: You can improve the data transfer rate by connecting a backup device directly to the application system. For information on configuring backup devices, see the *HPE Data Protector Help* index: "backups devices: configuring". For information on performing a restore using another device, see the *HPE Data Protector Help* index: "selecting, devices for restore".

Chapter 32: Troubleshooting

Before you begin

This chapter lists general checks and verifications that you may need to perform when you encounter problems with the Data Protector EMC VMAX Family integration. For general Data Protector troubleshooting information, see the *HPE Data Protector Troubleshooting Guide*.

- Ensure that the latest official Data Protector patches are installed. For information on how to verify this, see the *HPE Data Protector Help* index: “patches”.
- For general Data Protector and integration-specific limitations, as well as recognized issues and workarounds, see the HPE Data Protector Product Announcements, Software Notes, and References.
- For an up-to-date list of supported versions, platforms, and other information, see <https://softwaresupport.hpe.com/>.

Checks and verifications

- On the application and backup systems, examine system errors logged into the debug.log file residing in the Data Protector log files directory.

Appendix

Scheduling ZDB sessions

To schedule a filesystem or disk image ZDB, create a new or modify an existing backup specification. For detailed steps, see the *HPE Data Protector Help* index: “scheduling backups on specific dates and times”.

For general information on scheduling, see the *HPE Data Protector Help* index: “scheduled backups”.

Scheduling ZDB to disk/disk+tape

Schedule Backup

Specify the desired backup time, frequency, duration, and type.

Recurring

None
 Daily
 Weekly
 Monthly

Time options

Time: 14:15
 Use starting
7/ 3/2007

Recurring options

Day 5 of every 3 month

Session options

Backup type: Full
Network load: High Medium Low
Backup protection: Default

Split mirror/snapshot backup

To disk+tape
To disk+tape
To disk

OK Cancel Help

Starting interactive ZDB sessions

Prerequisites

- In a Microsoft Cluster Service configuration, if a cluster resource disk is to be backed up, it should not be in a maintenance mode before the backup.

Note: When running concurrent ZDB sessions using one or several application systems, consider the

limitations described in the *HPE Data Protector Concepts Guide*.

Using the GUI

1. In the **Context List**, select **Backup**.
2. In the Scoping Pane, expand **Backup**, **Backup Specification**, and **Filesystem**. Right-click the required backup specification, and select **Start Backup**.
3. The **Start Backup** dialog box appears.

For ZDB to tape and ZDB to disk+tape, specify **Backup Type**.

To run ZDB to disk or ZDB to disk+tape (**Track the replica for instant recovery** selected), select **To disk** or **To disk+tape** in the **Split mirror/snapshot backup** drop-down list.

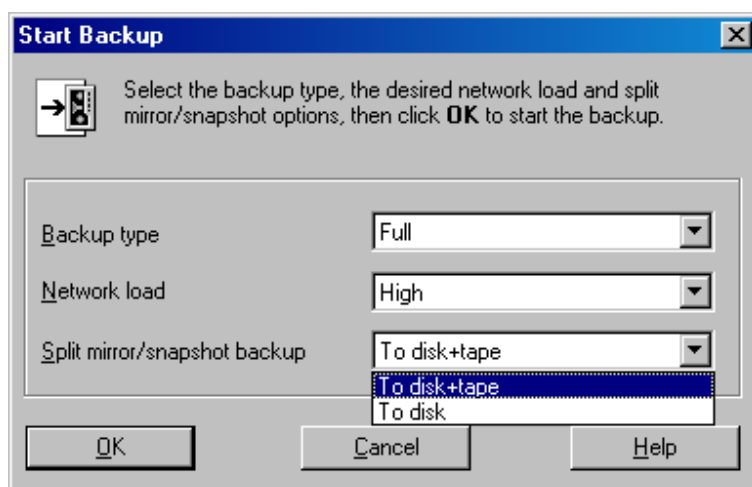

For information on options, press **F1**.

4. Click **OK**.

Using the CLI

Execute:

ZDB to tape, ZDB to disk+tape: `omnib -datalist Name`

ZDB to disk: `omnib -datalist Name -disk_only`

where *Name* is the backup specification name. For details, see the *HPE Data Protector Command Line Interface Reference* or the `omnib` man page.

Alternate paths support

For systems with multiple host adapters and connections to a disk array, the multi-path device management solution performs dynamic load balancing and monitors each path to ensure that the I/O

subsystem completes its transactions. If a path between a disk array and a server fails, alternate path software automatically switches to an alternate path, removing the failed path from I/O rotation without data loss. Failover is transparent to applications, so they continue unaffected.

Note: On UNIX systems, the multi-path device management software used for the Data Protector HPE P6000 EVA Disk Array Family integration to import volume groups on the backup system should be limited to the maximum supported number of paths.

Note: On HP-UX 11.31 systems, the multi-path device management software is not supported since the operating system has native device multi-pathing capability.

For information on which multi-path device management solutions are supported by specific Data Protector ZDB agents and disk array models, see the latest support matrices at <https://softwaresupport.hpe.com/>.

With the HPE P9000 XP Disk Array Family, you can control AutoPath load balancing using the `OB2AUTOPATH_BALANCING_POLICY` omnirc option (by default, AutoPath Round Robin load balancing policy is used). For more information, see "ZDB omnirc options" on page 248.

When using AutoPath, consider the following:

- During a ZDB-to-tape session, if a failover to an alternate path occurs and the AutoPath Shortest Queue Length load balancing is set, the session completes with errors.
- If a failover to an alternate path occurs during disk image backup without using raw logical volumes (rvols), the session completes with errors. If rvols are used, the session completes successfully.

Note: When using a disk array of the HPE P6000 EVA Disk Array Family together with the multi-path device management software HPE Secure Path, load balancing as configured by HPE Secure Path is used; you cannot change the load balancing policy using Data Protector.

Cluster configurations

Data Protector ZDB agents support:

- HPE Serviceguard (on HP-UX systems) with all disk array models supported by Data Protector
- Veritas Cluster (on Solaris systems) with disk arrays of the HPE P6000 EVA Disk Array Family and the HPE P9000 XP Disk Array Family
- Microsoft Cluster Server (on Windows systems) with disk arrays of the HPE P6000 EVA Disk Array Family and the HPE P9000 XP Disk Array Family
- EMC GeoSpan for Microsoft Cluster Service (on Windows systems) with EMC Symmetrix disk arrays

If the application system is in a server cluster, the backup system must be outside this cluster: it may run in a different cluster or may not be part of a cluster at all.

If the backup system is running in a server cluster, target volumes on this system must not be configured as cluster resources.

If a failover to the remote site happens, the disk array configuration changes from the combined HPE CA+BC P9000 XP (HPE P9000 XP Disk Array Family) or SRDF+TimeFinder (EMC Symmetrix) to

HPE BC P9000 XP (HPE P9000 XP Disk Array Family) or TimeFinder (EMC Symmetrix). This means that the next ZDB session can no longer start automatically, so the ZDB backup specification must be updated to reflect the configuration change.

For more information on cluster support, see the HPE Data Protector Product Announcements, Software Notes, and References and the *HPE Data Protector Help* index: "cluster".

Sections below discuss supported ZDB cluster configurations.

"Client on the application system in a cluster " on page 234 through "EMC GeoSpan for Microsoft Cluster Service " on page 237 illustrate Data Protector *application* backup disk array configurations and scenarios. For *filesystem and disk image* backup, only a Data Protector ZDB agent is needed; an application database and binaries are not installed as presented in the figures. On Windows systems, to perform zero downtime backup and instant recovery using Microsoft Volume Shadow Copy Service, the Data Protector component MS Volume Shadow Copy Integration must be installed.

Note: For applications in a cluster, use a floating IP address rather than a static one. This allows a successful backup to start even after a local failover.

Client on the application system in a cluster, Cell Manager in a cluster

Cell Manager is installed in a cluster on any system that is not a backup or application system.

Scenarios

- Application failover during backup: session fails and must be restarted manually.
- Application failover before backup: session completes successfully.
- Cell Manager failover during backup: failed session is automatically restarted, provided the option **Restart backup of all objects** is selected.
- Cell Manager failover before backup: session completes successfully.

Limitations

- Not supported in Veritas Cluster.

Install:

- On the application system on all cluster nodes on local disks: application binaries, Data Protector integration software component, Data Protector ZDB agent.
- On the application system cluster shared disk: application database. Note that this shared disk must be on a disk array.
- On any system cluster shared disk: Cell Manager.
- On the backup system on local disks: Data Protector integration software component, Data Protector ZDB agent, Data Protector General Media Agent.

Client on the application system in a cluster, Cell Manager in a cluster

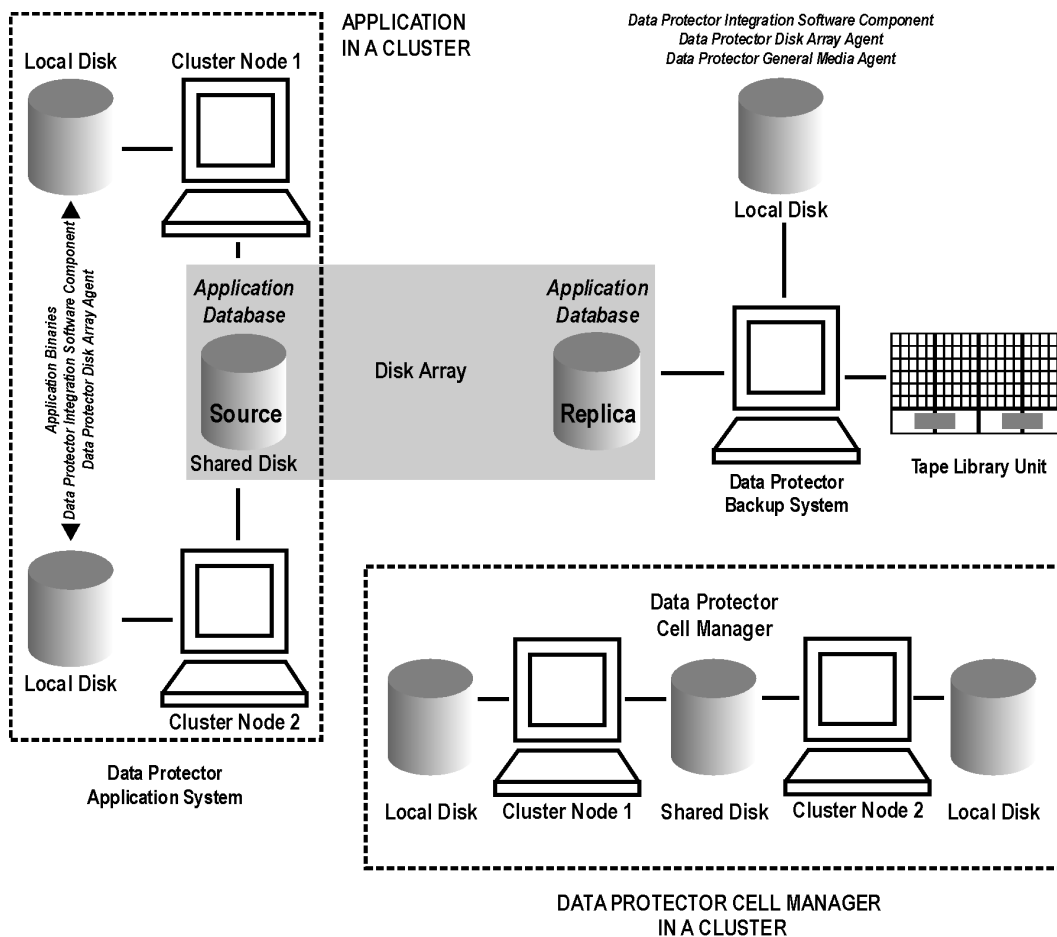

Cell Manager on the backup system in a cluster

Scenarios

- Cell Manager failover during backup: session is automatically restarted, provided the option **Restart backup of all objects** is selected.
- Cell Manager failover in between backups: session completes successfully.

Limitations

- Not supported in Veritas Cluster.

Install:

- On the application system: application binaries, Data Protector integration software component, Data Protector ZDB agent.
- On the application system cluster shared disk: application database. Note that this shared disk must be a disk array replicated disk.
- On the backup system cluster shared disk: Cell Manager. Note that this shared disk must be a disk array replicated disk.

- On the backup system on all cluster nodes on local disks: Data Protector integration software component, Data Protector ZDB agent, Data Protector General Media Agent.

Cell Manager on the backup system in a cluster

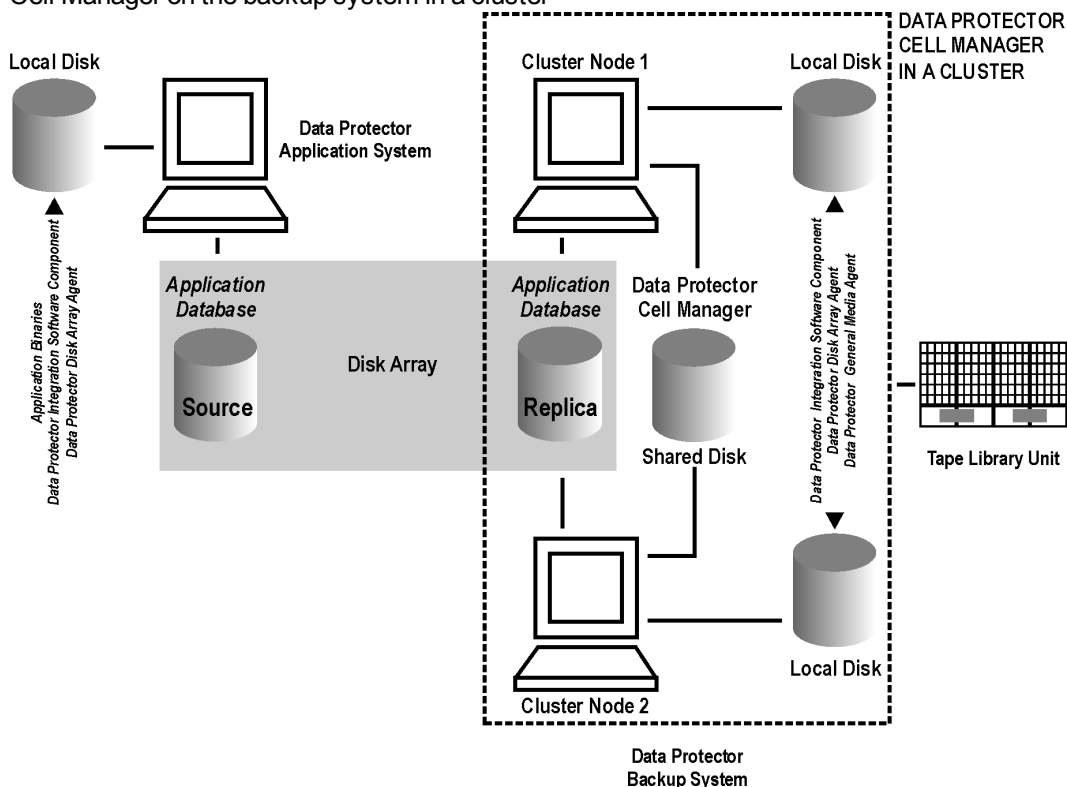

Cell Manager and client on the application system in a cluster

Scenarios

- Application or Data Protector failover during backup: session is restarted automatically.
- Application or Data Protector failover in between backups: session completes successfully.

Limitations

- Not supported in Veritas Cluster.
- Split mirror restore is not possible (HPE P9000 XP Disk Array Family, EMC Symmetrix).

Install:

- On the application system on all cluster nodes on local disks: application binaries, Data Protector integration software component, Data Protector ZDB agent.
- On the application system cluster shared disk: application database. Note that this shared disk must be a disk array replicated disk.
- On the application system cluster shared disk: Cell Manager.

- On the backup system on local disks: Data Protector integration software component, Data Protector ZDB agent, Data Protector General Media Agent.
- Configure Cell Manager cluster's critical resources in the same cluster group/package as those for the application being backed up.

Cell Manager and client on the application system in a cluster

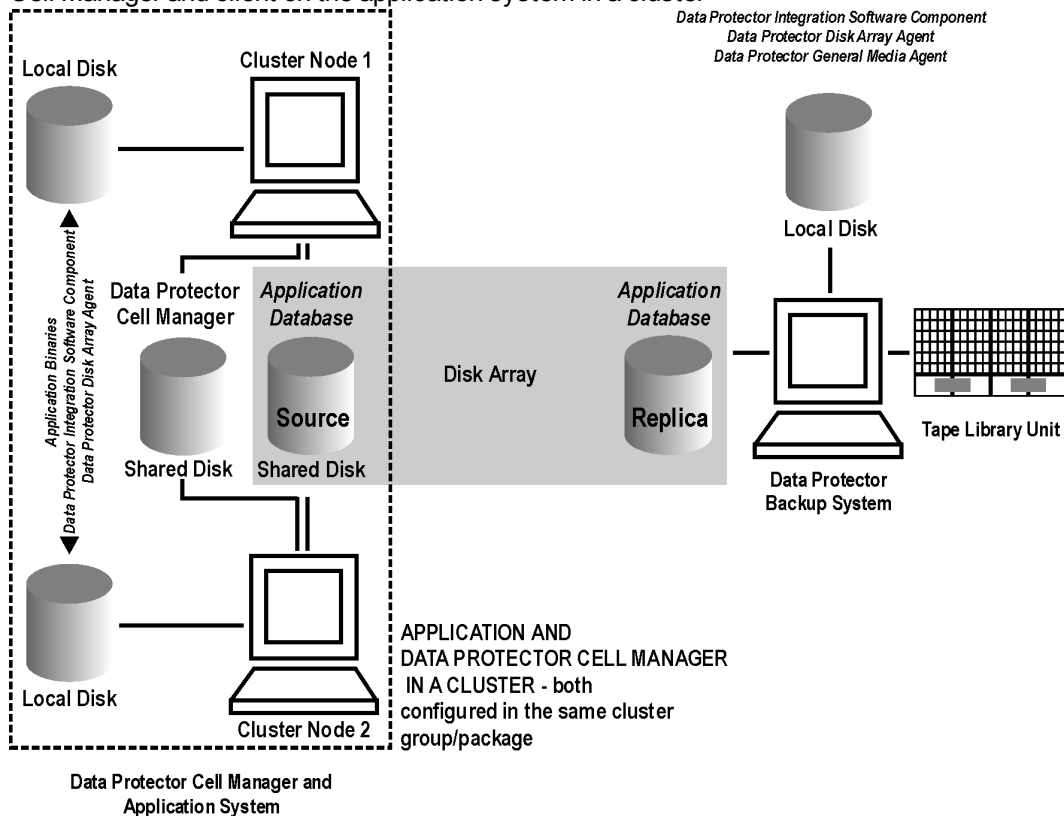

Client on the application system in a cluster, Cell Manager not in a cluster

Scenarios

- Application failover during backup: session fails and must be restarted manually.
- Application failover in between backups: session completes successfully.

Install:

- On the application system on all cluster nodes on local disks: application binaries, Data Protector integration software component, Data Protector ZDB agent.
- On the application system cluster shared disk: application database. Note that this shared disk must be on a disk array.
- On the backup system on local disks: Data Protector integration software component, Data Protector ZDB agent, Data Protector General Media Agent.

Client on the application system in a cluster

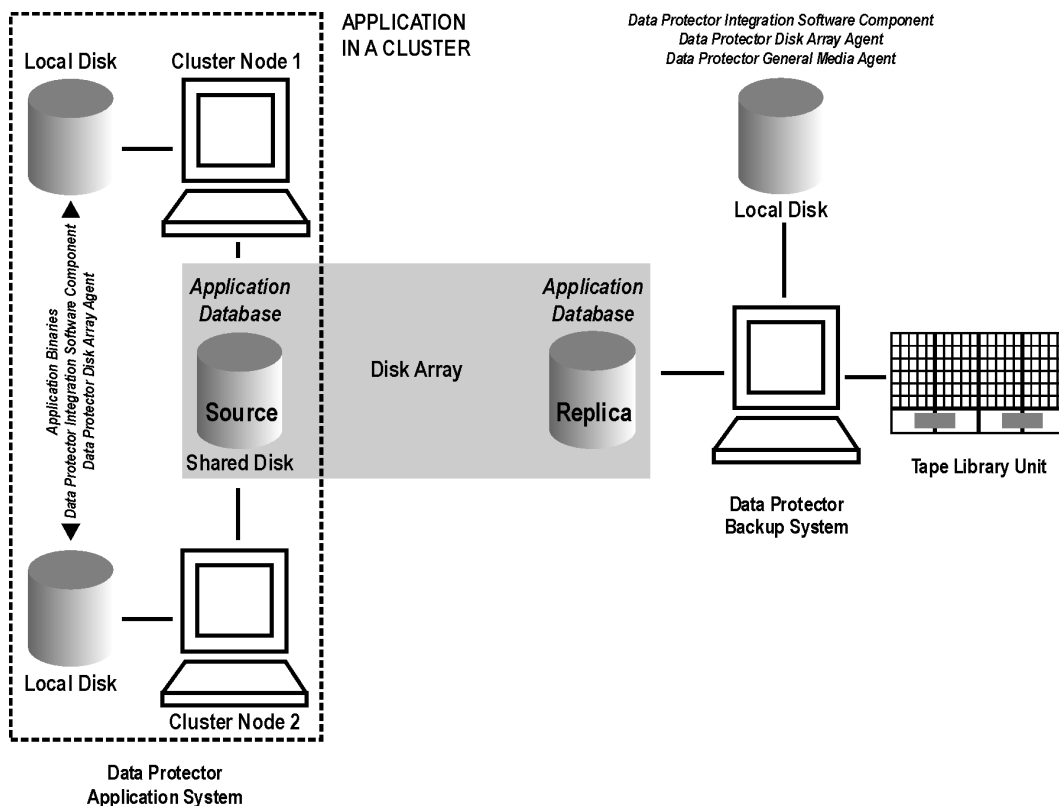

Client on the application system in a cluster, Cell Manager on the backup system in a cluster

Scenarios

- Application failover during backup: session fails and must be restarted manually.
- Application failover before backup: session completes successfully.
- Cell Manager failover during backup: failed session is automatically restarted, provided the option **Restart backup of all objects** is selected.
- Cell Manager failover before backup: session completes successfully.

Limitations

- Not supported in Veritas Cluster.

Install:

- On the application system on all cluster nodes on local disks: application binaries, Data Protector integration software component, Data Protector ZDB agent.
- On the application system cluster shared disk: application database. Note that this shared disk must be a disk array replicated disk.
- On the backup system cluster shared disk: Cell Manager.

- On the backup system on all cluster nodes on local disks: Data Protector integration software component, Data Protector ZDB agent, Data Protector General Media Agent.

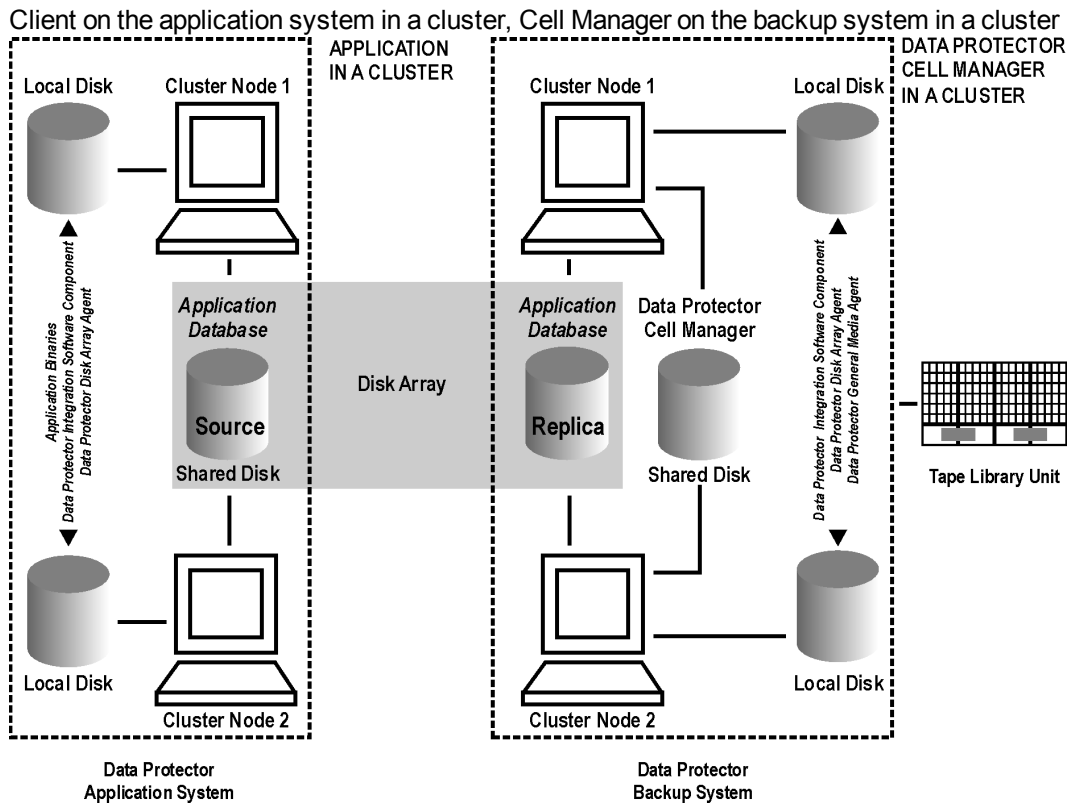

EMC GeoSpan for Microsoft Cluster Service

Cell Manager is not in a cluster; application client is in a cluster on the application system.

EMC Symmetrix SRDF links are controlled by EMC GeoSpan, EMC Symmetrix TF links are controlled by Data Protector.

Scenarios

- Application/hardware failover during backup: session fails and must be restarted manually. The backup system in the backup specification must be set as the backup system for the active node.
- Application failover before backup: session completes successfully if the backup system is set as the backup system for the active node.

Install:

- On the application system on all cluster nodes on local disks: application binaries, Data Protector integration software component, EMC Agent.
- On the application system cluster shared disk: application database. Note that this shared disk must be a disk array replicated disk.
- On the backup system on local disks: Data Protector integration software component, Data Protector EMC Agent, Data Protector General Media Agent.

EMC GeoSpan for Microsoft Cluster Service

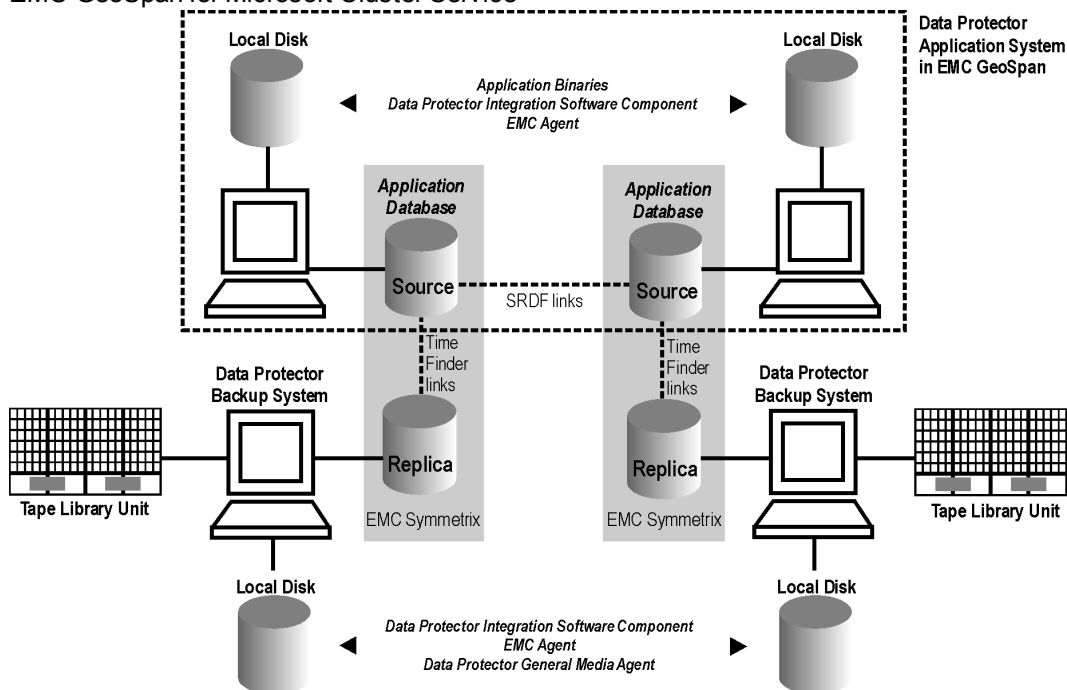

Instant recovery in a cluster

With an application or filesystem running on HPServiceguard or Microsoft Cluster Server on the application system, instant recovery requires some *additional* steps. Additionally, there are limitations regarding instant recovery on Microsoft Cluster Server.

If HP-UX LVM mirroring is used, see also ["Instant recovery and LVM mirroring" on page 111](#).

Veritas Cluster Volume Manager

Prerequisites

Before performing the instant recovery in Veritas Cluster, ensure the following:

- SMISA Agent must run on the master node during instant recovery.
- The File System must be dismounted on all other hosts, except the master node before instant recovery.
- The `/etc/default/vxdg` file must be created with the following content in the master node:
`enable_activation=true`

Note: Restart the daemon file using the following command:
`vxconfigd -k`

HPE Serviceguard

Procedure

1. Stop the application cluster package:

```
cmhaltpkg ApplicationPackageName
```

2. In the *shell script for starting, shutting down and monitoring the database*, comment the lines that monitor application processes (by putting # at the beginning of the line).

Oracle example

```
#set -A MONITOR_PROCESSES ora_pmon_${SID_NAME} ora_dbw0_${SID_NAME} ora_ckpt_${SID_NAME} ora_smon_${SID_NAME} ora_lgwr_${SID_NAME} ora_reco_${SID_NAME} ora_arc0_${SID_NAME}
```

This shuts down the application (database) running in the cluster without causing a failover.

3. Restart the application cluster package:

```
cmrunpkg ApplicationPackageName
```

4. Shut down the application (database).

5. Start instant recovery. For instructions, see:

- ["Instant recovery procedure" on page 59](#) (P6000 EVA Array)
- ["Instant recovery procedure" on page 108](#) (P9000 XP Array)

When performing instant recovery to the node other than that backed up, select the **Check the data configuration consistency** instant recovery option.

6. When the session finished, stop the application cluster package:

```
cmhaltpkg ApplicationPackageName
```

7. Uncomment the lines (delete #) commented in ["In the shell script for starting, shutting down and monitoring the database, comment the lines that monitor application processes \(by putting # at the beginning of the line\)." above](#) of this procedure to re-enable an application failover.

8. Restart the application cluster package:

```
cmrunpkg ApplicationPackageName
```

9. After instant recovery, recover the database. For detailed procedures, see the database documentation.

Note: After resynchronization with the application system finishes, enable replicated volume groups on the application system in the exclusive mode by setting the ZDB_IR_VGCHANGE_A omnirc option on the application system to `vgchange -a e`. For more information, see ["ZDB omnirc options" on page 248](#).

Microsoft Cluster Server

Limitations

- Instant recovery of a cluster quorum disk is not supported because the cluster service must never lose the connection with the quorum disk, which happens during instant recovery (when disks are unrepresented).
- In the configuration where a local disk is mounted to a cluster resource disk, instant recovery of a such disk is not supported.
- Any target cluster disk resource must be owned by the currently active node. Instant recovery is not supported if the disk resource is owned by the non-active node.
- Instant recovery of combination of cluster and non-cluster disks is not supported.

Considerations

- In a Microsoft Cluster Server environment, disks are distinguished by their disk signature. Because two disks cannot have the same signature, the operating system dynamically changes the signature once it detects the replica on the backup system. During the instant recovery procedure, Data Protector restores the disk signature to ensure that the recovered disk will have the same signature as the original disk on the application system. Data Protector will display notifications, informing you about the changed signature.

Prerequisites

- On Windows Server 2008 systems, before running an instant recovery session, you need to bring the original disks online.

Procedure

1. Using the Cluster Administrator utility or Cluster CLI, take the application cluster resource offline. For detailed instructions, see the Microsoft Cluster Server documentation.
2. Shut down the application (database).
3. Start instant recovery. For instructions, see:
 - ["Instant recovery procedure" on page 59](#) (P6000 EVA Array)
 - ["Instant recovery procedure" on page 108](#) (P9000 XP Array)
4. Restart the application (database).
5. Recover the database. For detailed procedures, see the database documentation.
6. Using the Cluster Administrator utility or CLI, put the application cluster resource online.

Instant recovery for in CA+BC configurations

Introduction

This section describes the steps to be followed for executing instant recovery in HPE Continuous Access + Business Copy (CA+BC) P6000 EVA environments of the HPE P6000 EVA Disk Array Family using Data Protector.

The section gives details of the following:

- The different situations where HPE CA+BC P6000 EVA impacts instant recovery
- Instant recovery concepts
- HPE CA+BC P6000 EVA configurations supported for instant recovery
- How to plan and perform instant recovery in HPE CA+BC P6000 EVA configurations

Prerequisites

You should be familiar with the following:

- *HPE Data Protector Concepts Guide*
- HPE storage management appliance (SMA) documentation
- HPE P6000 EVA Disk Array Family documentation
- Failover or cluster-failover documentation, such as the *HPE Cluster Extension EVA user guide*

Overview

With instant recovery, lost or corrupted data (or rather, the whole volumes containing it) is replaced with known good data. This good data resides on whole storage volumes, or virtual disks, which have been created previously as an HPE BC P6000 EVA during a ZDB. These replicated target volumes are used for restores internally within the array, involving no other backup medium or device.

The general SMISA instant recovery flow is as follows:

1. The application system is prepared for restore by dismounting filesystems and taking volume groups offline.
2. Source volumes are masked or unrepresented from the application system.
3. The identities of each matched pair of source and target storage volumes are exchanged. This involves the WWN, the name, and the comments of each volume.
4. The exchanged storage volume is unmasked or presented to the application system.
5. Volume groups are put online and filesystems remounted.

Each source storage volume that is backed up using ZDB has a matching target storage volume in the replica.

Note: To enable instant recovery, each pair of matched replica and source storage volumes must reside on the same disk array. This is required for a valid exchange of identities (step 3 in the general instant recovery flow above).

However, when a source volume is attached to a DR group and so participates in remote replication, the P6000 EVA Array does not allow the WWN of that virtual disk to be modified. Therefore, to prepare your environment for instant recovery and successfully recover your data, you need to carry out the following steps:

1. Manually prepare the storage volumes and the storage environment for instant recovery, as described in ["Instant recovery in HPE CA+BC P6000 EVA environments"](#) on page 243.
2. Perform instant recovery with the Data Protector HPE P6000 / HPE 3PAR SMI-S Agent.
3. Optionally, return the storage volumes and storage environment to the state they were in before instant recovery.

The following sections outline different HPE CA+BC P6000 EVA configurations and the manual steps you need to follow for successful instant recovery.

Supported instant recovery configurations

The manual steps needed to prepare the environment for instant recovery and bring it back after instant recovery differ depending on the current configuration of HPE CA+BC P6000 EVA or DR group connections.

Identifying the setup depends on the following environment information:

- The current site for the source side of any DR groups that include the source storage volumes
- Whether the HPE BC P6000 EVA or target storage volumes are on the same array as the source storage volumes (*local*), or on the remote side of the DR group (*remote*)

From this information, there are two possible configurations:

- Configuration I – HPE Business Copy P6000 EVA is on the local side of the HPE CA P6000 EVA link
- Configuration II – HPE Business Copy P6000 EVA is on the remote side of the HPE CA P6000 EVA link

Configuration I – local HPE Business Copy P6000 EVA

Replicas on the local site

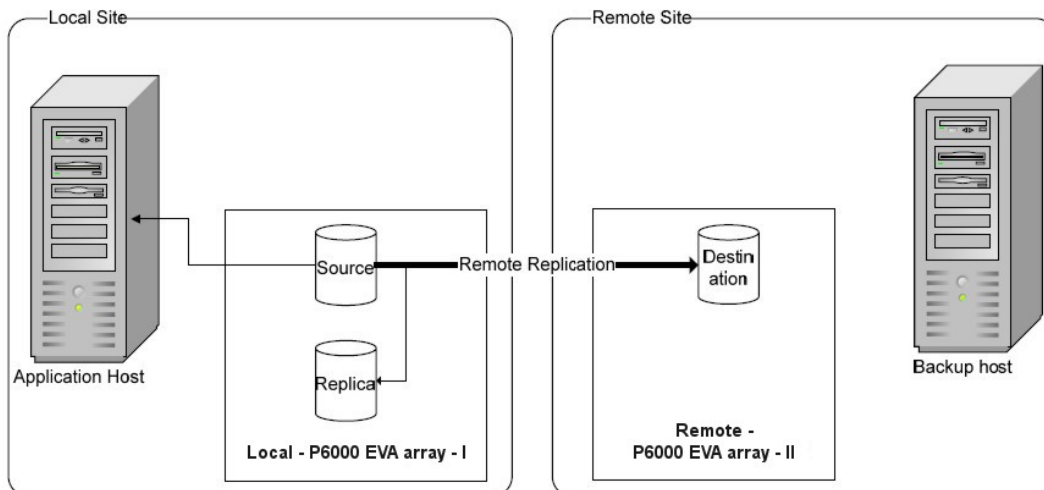

In this configuration, at the time of instant recovery, the source and replica storage volumes reside on the current local site.

Note: The source storage volume (“Source” in the diagram) acts as both the source of the replica storage volume and the source for the remotely replicated storage volume (“Destination” in the diagram).

The configuration may be a result of any of the following:

- Performing an HPE BC P6000 EVA backup of a volume that is remotely replicated at backup time.
- Adding remote replication to a storage volume that was previously backed up by an HPE BC P6000 EVA backup.
- Performing an HPE CA+BC P6000 EVA backup with the HPE BC P6000 EVA on the current local site.

Configuration II – remote HPE Business Copy P6000 EVA

Replicas on the remote site

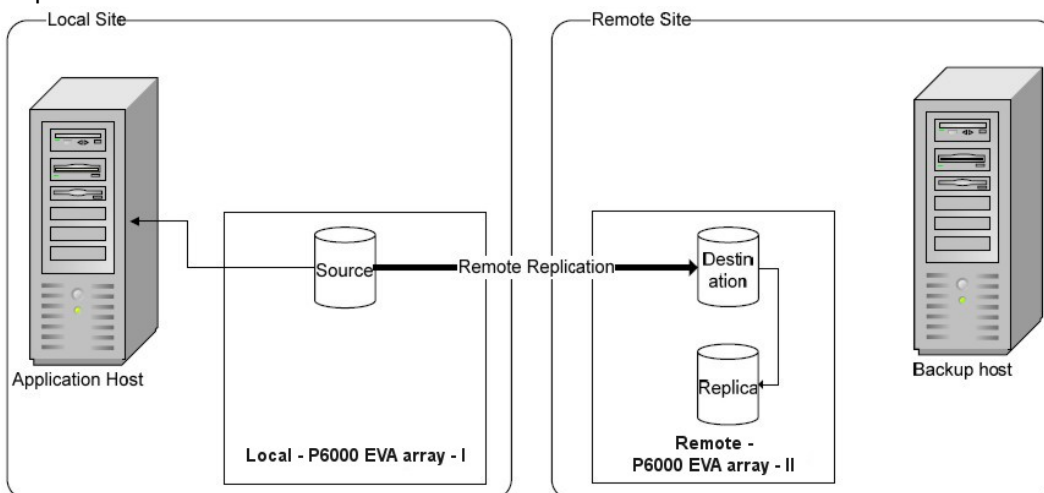

In this configuration, at the time of instant recovery, the customer environment has the source virtual disk residing on the local site. The remote replica (the replica of the source virtual disk replicated using HPE CA P6000 EVA) and its local replica are both on the remote site.

Note: The storage volume marked “Destination” in the diagram is both the *destination* of the remote replication link and the *source* of the replica storage volume.

Such a configuration may be a result of any of the following:

- Performing an HPE BC P6000 EVA backup of a storage volume that is remotely replicated, and then failing over the environment.
- Adding remote replication to a volume that was previously backed up by an HPE BC P6000 EVA backup, and then failing over the environment.
- Performing an HPE CA+BC P6000 EVA backup with the HPE BC P6000 EVA on the current remote site.

Instant recovery in HPE CA+BC P6000 EVA environments

The initial steps of preparation for instant recovery are as follows:

1. Understand the current configuration of the environment.
2. Optionally, perform a DR group failover.
3. Modify the DR group so that the source storage volumes involved in restore no longer participate in the DR group.

The following flow chart summarizes this general process.

General instant recovery flow in HPE CA+BC P6000 EVA environments

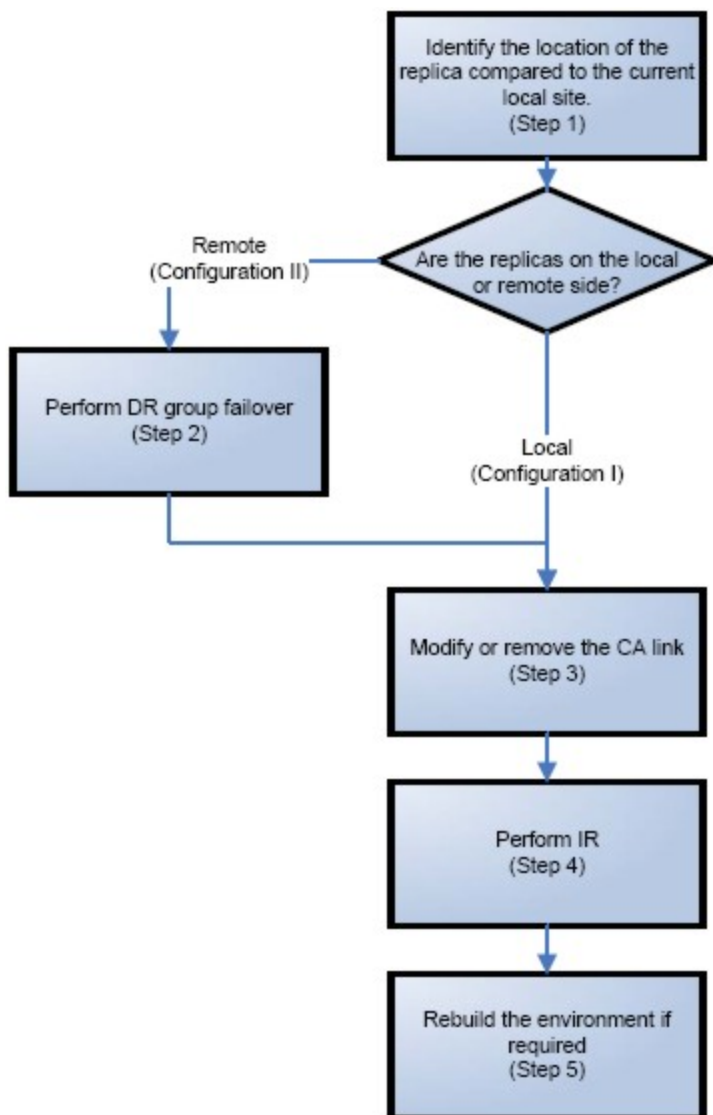

Step 1: Identifying the current configuration

The following steps help identify the location of the source and target volumes:

1. Select the session for which instant recovery will be performed.

List the sessions available for instant recovery using the Data Protector GUI (the **Instant Recovery** context) or the Data Protector CLI (the `omnidbsmis` command)

```
# omnidbsmis -list -session -ir
Found 2 P6000 EVA SMI-S session(s) in the internal \
database:
```

Session ID	IR	Type	Excluded	Backup Specification
2010/06/20-5	Yes	Snapclone	No	VolDpdevpa2

```
2010/06/20-6 Yes Snapclone No VolDpdevpa2  
#
```

2. Identify the source objects and the HPE CA P6000 EVA link information.

Query the objects of the specific session using the `omnidbsmis` command. The following example is for a session with ID 2010/06/20-5.

```
# omnidbsmis -show -session 2010/06/20-5
```

```
Info on session "2010/06/20-5":
```

```
Target volume virtual disk name : \Virtual Disks\SNEHA\DP-200  
8.06.20-5-04497CA1A\ACTIVE  
Target volume virtual disk ID   : 6005-08b4-0010-3a70-0000-90  
00-0661-0000  
Target volume virtual disk WWN  : 6005-08b4-0010-3a70-0000-90  
00-0661-0000  
P6000 EVA Array Family name   : DPCA  
P6000 EVA Array Family ID    : 5000-1fe1-5005-dc0  
0  
Target volume snapshot type    : Snapclone  
Source volume virtual disk ID   : 6005-08b4-0010-3a70-0000-90  
00-0042-0000  
Session ID                    : 2010/06/20-5  
Creation Date                  : Sun Jun 20 15:42:42 2010  
  
IR flag                        : 1  
Excluded                       : 0  
Source disk version            : 0  
Backup specification           : VolDpdevpa2  
Application System             : dpdevpa2.hp.com  
Backup System                  : dpdevpa2.hp.com  
#
```

From this output, you can find the following information:

- The target/replica virtual disk WWN, UUID, and the name:
 - *WWN and UUID:* 6005-08b4-0010-3a70-0000-9000-0661-0000,
 - *Name:* \Virtual Disks\SNEHA\DP-2010.06.20-5-04497CA1A\ACTIVE
- The source (of the replica) virtual disk UUID:
 - *UUID:* 6005-08b4-0010-3a70-0000-9000-0042-0000
- The P6000 EVA Array name and the WWN where the matched source and target volumes exist:
 - *Name:* DPCA
 - *WWN:* 5000-1fe1-5005-dc00

3. Use this information to locate the source storage volume and the P6000 EVA Array where it resides. You can also locate the target storage volume or the target virtual disk to verify that it still

exists:

- a. Connect to the Storage Management Appliance or any other CV EVA management host that manages the specific P6000 EVA Array storage system.
- b. Browse through the **Virtual Disk** folder until the virtual disk with a matching UUID is found.

In the following figure, the source virtual disk with a UUID of 6005-08b4-0010-3a70-0000-9000-0042-0000 has been located:

Locating the source virtual disk

The screenshot shows the 'Vdisk Active Member Properties' window with the 'Data Replication' tab selected. The 'Data Replication' tab is circled in red, with a callout box pointing to it labeled 'Data Replication tab'. The 'UUID' field is also circled in red, with a callout box pointing to it labeled 'UUID of the source disk'. The 'Condition State' is 'Good' and the 'Operational State' is 'Good'. The 'Created' date is '12-Jun-2006 16:21:02'. The 'Capacity' is '10 GB'. The 'Cache Policies' are 'Read cache: On', 'Mirror cache: Mirrored', and 'Write cache: Write-back'.

- c. Select the **Data Replication** tab to identify HPE CA P6000 EVA link properties for this virtual disk. The following information should be gathered from this panel:

- o DR group name
- o DR mode

Checking the DR mode

The screenshot shows the 'Vdisk Active Member Properties' window with the 'Data Replication' tab selected. The 'Data Replication Properties' section is visible. The 'DR group' field is circled in red, with a callout box pointing to it labeled 'DR group name'. The 'DR Mode' field is also circled in red, with a callout box pointing to it labeled 'Source/Destination property of the DR group'. The 'Group Failsafe mode' is 'Enabled', 'Group Failsafe state' is 'Unlocked', and 'Group log state' is 'Not in use'. The 'Destination Vdisks' table is also visible.

Vdisk	Copy State	Copy Status
WDPRNDVirtual Disks\qiaux10_FSACTIVE	Normal	n/a

The DR mode is used to identify the configuration of the current environment:

- o If the DR mode is "Source", the current environment is Configuration I – local HPE Business Copy P6000 EVA. In this case, proceed to ["Step 3: Modifying or removing the HPE CA P6000 EVA link" on the next page.](#)
- o If the DR mode is "Destination", the current configuration is Configuration II – remote

HPEBusiness Copy P6000 EVA. In this case, proceed to "[Step 2: Performing failover](#)" below.

Note: Complex environments may include a mixture of Configuration I and Configuration II. In this scenario, business copies exist that are both local and remote in relation to the source storage volumes. To handle this, perform the actions stated in Step 2: Performing Failover only to the DR groups with the "Destination" DR mode.

Step 2: Performing failover

Use the information you have gathered regarding DR groups to perform failover as appropriate for the environment. For simple environments, this may include interactions with CV EVA or HPE CA P6000 EVA GUI, as well as some configuration steps on the application system. Before taking such actions, see the appropriate documentation for full details.

For more complex environments, including clusters or other high-availability solutions, see the appropriate documentation for that solution before performing any failover actions.

After performing the failover, proceed to step 3 to modify or remove the HPE CA P6000 EVA link.

Step 3: Modifying or removing the HPE CA P6000 EVA link

Note: Before taking any action, record the information relating to the DR groups. This includes such things as the virtual disks participating in the DR group, which P6000 EVA Array storage systems are being replicated to, the mode of operation, and other specific details.

Modify the environment so that the source virtual disks no longer participate in a DR group. You can do this in either of two ways:

- Reduce the DR group by removing each source virtual disk. Do this if the environment is complex and simplifying the DR groups will make it easier to reconfigure the environment.
- Delete the DR group completely. Do this if the HPE CA P6000 EVA links are no longer needed or are easily reconfigurable.

For details of these methods, see the CV EVA user documentation or other specific documentation.

In the case of a DR group reduction, there may only be source storage volumes inside the DR group. A DR group must always have at least one virtual disk participating. In this case, it is advisable to create a temporary virtual disk and add it to the DR group. With this temporary storage volume, all source storage volumes may be removed from the DR group, and the DR group will still persist.

When this has been completed, proceed to step 4 to perform the instant recovery.

Step 4: Performing instant recovery

Using the Data Protector GUI or CLI, perform instant recovery with the selected session. This should complete successfully with the appropriately reconfigured environment.

When this has been completed, optionally proceed to rebuilding the HPE CA P6000 EVA link.

Step 5: Rebuilding the HPE CA P6000 EVA link (optional)

If required, return the new source virtual disks to the specific DR groups. Using the information you recorded in step 3 regarding the environment and specific DR groups, either rebuild or recreate the DR groups.

Note: Ensure that you use the newly-recovered storage volumes for this rebuild of the HPE CA P6000 EVA links. These storage volumes should have the same names and the WWNs as the storage volumes used previously. However, as these are different virtual disks, the UUIDs will be different from those used by the application system before for the virtual disks.

For details, see the CV EVA documentation. You may also need to perform additional steps to bring the environment to the same initial state, including failing over the HPE CA P6000 EVA links again, to return operation to the correct P6000 EVA Array storage systems and application servers.

ZDB omnirc options

To customize operation of the ZDB agents, you can set the `omnirc` options on the application system and the backup system. Changes to the options in the `omnirc` file on a particular system do not affect the agents that are already running on the system at the moment the changes are made. For information on the `omnirc` file, see the *HPE Data Protector Troubleshooting Guide* or the *HPE Data Protector Help* index: "omnirc". Instructions on how to set the options are provided in the file itself.

Common ZDB options

This section explains `omnirc` options that can be set for all ZDB agents.

ZDB_PRESERVE_MOUNTPOINTS: Determines, together with `ZDB_MULTI_MOUNT` and `ZDB_MOUNT_PATH`, the mount point creation on the backup system.

If `ZDB_PRESERVE_MOUNTPOINTS` is set to 0 (default value), the mount point for a backed up filesystem is created as follows:

- When `ZDB_MULTI_MOUNT` is set to 1:

- **P6000 EVA Array:**

`BU_MOUNT_PATH/Application_System_Name/Mount_Point_Name_on_Application_System_SessionID`

- **P9000 XP Array:**

`BU_MOUNT_PATH/Application_System_Name/Mount_Point_Name_on_Application_System_LDEV_MU#`

- When `ZDB_MULTI_MOUNT` is set to 0 or not set:

`BU_MOUNT_PATH/Application_System_Name/Mount_Point_Name_on_Application_System`

where `BU_MOUNT_PATH` corresponds to one of the following locations on a Data Protector client:

- With ZDB_MOUNT_PATH set: *ZDB_MOUNT_PATH*
- With ZDB_MOUNT_PATH not set:
 - **Windows Server 2008:** *Data_Protector_program_data\tmp*
 - **Other Windows system:** *Data_Protector_home\tmp*
 - **UNIX systems:** */var/opt/omni/tmp*

If ZDB_PRESERVE_MOUNTPOINTS is set to 1, the mount point for a backed up filesystem is created on the backup system at:

- **Windows systems:** *\Mount_Point_Name_on_Application_System* or *Drive_Letter_on_Application_System:*
- **UNIX systems:** */Mount_Point_Name_on_Application_System*

For zero downtime backup of disk images, Oracle 8/9/10 databases, SAP R/3 databases, and Microsoft SQL Server 2000 databases, Data Protector adopts that ZDB_PRESERVE_MOUNTPOINTS is set to 1, and ignores its override and the options ZDB_MULTI_MOUNT and ZDB_MOUNT_PATH.

ZDB_MULTI_MOUNT: Determines, together with ZDB_PRESERVE_MOUNTPOINTS and ZDB_MOUNT_PATH, the mount point creation on the backup system.

ZDB_MULTI_MOUNT is ignored if ZDB_PRESERVE_MOUNTPOINTS is set to 1.

If ZDB_MULTI_MOUNT is set to 1 (default value), *SessionID* (P6000 EVA Array) or *LDEV MU#* (P9000 XP Array) is appended at the end of the mount point path, thus enabling every group of mount points for one replica in the replica set to be mounted to their own mount points.

If ZDB_MULTI_MOUNT is set to 0, the selected group of mount points for one replica in the replica set is mounted to the same mount points.

With EMC Symmterix, this option is ignored and Data Protector adopts that it is set to 0.

ZDB_MOUNT_PATH: Determines, together with ZDB_PRESERVE_MOUNTPOINTS and ZDB_MULTI_MOUNT, the mount point creation on the backup system.

ZDB_MOUNT_PATH is ignored if ZDB_PRESERVE_MOUNTPOINTS is set to 1.

By default, this option is not set. In this case, the first part of the mount point path is defined as:

Windows Server 2008, Windows Server 2012: *Data_Protector_program_data\tmp*

Other Windows systems: *Data_Protector_home\tmp*

UNIX systems: */var/opt/omni/tmp*

To set this option, specify the first part of the mount point path.

Note: If the option **Use the same mountpoints as on the application system** is not selected in the GUI, the option ZDB_MOUNT_PATH is ignored and values of the ZDB options **Root of the mount path on the backup system** and **Add directories to the mount path** specified in the Data Protector GUI are used for mount point creation in the ZDB session instead.

ZDB_ALWAYS_POST_SCRIPT: By default, the command specified in the option **Restart the application command line** is not executed if the command specified in the option **Stop/quiesce the application command line** fails.

If this option is set to 1, the command specified in the option **Restart the application command line** is always executed.

Default: 0.

ZDB_IR_VGCHANGE: On HP-UX platform, determines the mode in which replicated volume groups on the application system are activated after restore. The option can be set on the application system only.

Note: This option is not supported on EMC.

Select from the following modes:

- *Exclusive:* ZDB_IR_VGCHANGE_A=vgchange -a e
- *Shared:* ZDB_IR_VGCHANGE_A=vgchange -a s
- *Normal (default):* ZDB_IR_VGCHANGE_A=vgchange -q n -a y

Use exclusive mode to enable instant recovery if an application/filesystem runs in the HPEServiceguard cluster on the application system.

ZDB_IR_MANUAL_AS_PREPARATION: To manually prepare the application system for instant recovery (dismounting filesystems and disabling volume groups), set this option to 1. After instant recovery, manually enable volume groups and mount filesystems again.

Use this option also if automatic preparation of the application system fails because the application data configuration changed after backup. For example, if a failover to a secondary cluster node occurred between backup and instant recovery, Data Protector may have difficulty matching the secondary node resources to resources that existed on the primary node during backup.

Default: 0.

P6000 EVA Array and 3PAR StoreServ Storage specific options

This section explains P6000 EVA Array and 3PAR StoreServ Storage specific omnirc options.

Besides the 3PAR_MSGWAITING_INTERVAL and 3PAR_COPYBACKSTS_QUERY_INTERVAL, the following options apply to the 3PAR StoreServ Storage: ZDB_VOLUMESCAN_RETRIES, ZDB_POST_RESCAN_INIT_DELAY, ZDB_LVM_PREFERRED_PVG, SMISA_MSGWAITING_INTERVAL, SMISA_FORCE_DISMOUNT, ZDB_DONOT_PRESENT_DISKS, ZDB_SKIP_LOCK_AT_DISMOUNT, ZDB_SMISA_LVM_MIRRORING_DISABLED, SMISA_CHECKFORABORT_DELAY, EVA_CIMOM_CONNECTION_TIMEOUT, EVA_CIMOM_QUERY_RETRIES, EVA_CIMOM_QUERY_INTERVAL.

See also "[Common ZDB options](#)" on page 248.

EVA_HOSTNAMEALIASES: Allows a given ID to match the P6000 EVA Array host objects.

Default: no hostnames specified. To add more hostnames to the search, specify hostname object names for this option.

Example

Your backup host is represented within CV EVA by:

- /Hosts/Backup hosts/MyHost_Port1
- /Hosts/Backup hosts/MyHost_Port2

To force P6000 EVA Array client to find these host objects, set:

```
EVA_HOSTNAMEALIASES=MyHost_Port1,MyHost_Port2
```

EVA_MSGWAITING_INTERVAL: Determines the time interval between messages reporting the snapclone creation progress (monitored during ZDB-to-tape and ZDB-to-disk+tape sessions immediately after the backup system preparation). The backup option `Delay the tape backup by a maximum of n minutes if the snapclones are not fully created` must be selected.

Default: 10 minutes.

EVA_CLONECREATION_QUERY_INTERVAL: Determines the time interval between queries checking the snapclone creation progress (appears during ZDB-to-tape and ZDB-to-disk+tape sessions immediately after backup system preparation). The backup option `Delay the tape backup by a maximum of n minutes if the snapclones are not fully created` must be selected. A shorter time interval ensures that snapclone completion is detected more promptly, but also increases the load on the P6000 EVA Array storage system.

Default: 5 minutes.

3PAR_MSGWAITING_INTERVAL: See **EVA_MSGWAITING_INTERVAL**

3PAR_COPYBACKSTS_QUERY_INTERVAL: Determines the time interval between status checks.

ZDB_VOLUMESCAN_RETRIES: During the backup system preparation, the system is scanned for new filesystem volumes. This option determines the number of scans required to identify the new volumes.

The option is only applicable on Windows.

Default: 5 retries. If scanning takes longer (a known problem on Windows Server 2003), increase the default setting.

ZDB_POST_RESCAN_INIT_DELAY: During the backup system preparation, the system is scanned for new filesystem volumes. This option sets the time period to wait before initiating next scan of new filesystem volumes.

The option is only applicable on Windows.

Default: 30 seconds.

ZDB_LVM_PREFERRED_PVG: With HP-UX LVM mirroring, determines the physical volume group (PVG) to be selected for HPE BC P6000 EVApair replication. Data Protector checks the value of this option when at least one logical volume identified as a backup object is mirrored.

The option format is as follows:

```
ZDB_LVM_PREFERRED_PVG=VGNAME1:PVG_NAME;VGNAME2:PVG_NAME; ...
```

For example, if three volume groups are participating in backup, you can define the following in your application system configuration file:

```
ZDB_LVM_PREFERRED_PVG=/dev/vg01:PVG-0;/vgApp1n1:PVG-1; /dev/vgApp1n2:PVG-1
```

When the backup objects are from the volume group `/dev/vg01`, the HPE P6000 / HPE 3PAR SMI-S Agent applies the mirror selection rules and prefers `PVG-0` over any other valid PVG defined for if when the same disk array is used. On other disk array, any valid PVG will be used.

ZDB_SMISA_LVM_MIRRORING_DISABLED: Determines if the LVM mirroring is enabled or not.

Default: 0 (LVM mirroring enabled). Possible: 0|1.

EVACA_QUERY_INTERVAL: Determines the time interval (in minutes) between queries of the P6000 EVA Array storage system for checking the progress of the logging and/or copying process on HPE CA+BC P6000 EVA. Such querying occurs during a ZDB-to-tape session immediately after backup system resolving.

Default: 5 minutes.

EVACA_WAIT_FOR_NORMAL_STATE: Determines if the HPE P6000 / HPE 3PAR SMI-S Agent has to wait for the DR group write history log (DR group log) to move out of the "logging", "copying", or "merging" state back to the "not in use" state. With this option set, the DR group log state is monitored for the time period set by `EVACA_LOGGINGSTATE_TIMEOUT`, `EVACA_COPYSTATE_TIMEOUT`, or `EVACA_MERGINGSTATE_TIMEOUT`. If at the end of the period the DR group log state has not returned to "not in use", the backup for the objects belonging to that DR group is aborted.

Default: 0 (not set). Possible: 0|1.

EVACA_WAIT_FOR_NORMAL_STATE_TIMEOUT: Determines the time interval (in minutes) to wait for the DR group write history log (DR group log) found in the "logging", "copying", or "merging" state to move to the "not in use" state. After the timeout, the backup process skips the objects belonging to DR groups whose log is a state other than "not in use", and continues with backup of other objects specified in a ZDB backup specification. The option is only considered when `EVACA_WAIT_FOR_NORMAL_STATE` is set to 1.

Default: 15 minutes.

EVACA_LOGGINGSTATE_TIMEOUT: Determines the time interval (in minutes) to wait for the DR group write history log (DR group log) found in the "logging" state to move to the "not in use" state. After the timeout, backup process skips the objects belonging to DR groups whose log is in the "logging" state, and continues with backup of other objects specified in a ZDB backup specification.

Default: 10 minutes.

EVACA_MSGWAITING_INTERVAL: Determines the time interval (in minutes) between messages that report the progress of the logging and/or copying process on HPE CA+BC P6000 EVA. This progress is monitored during a ZDB-to-tape session immediately after backup system resolving.

Default: 10 minutes.

EVACA_COPYSTATE_TIMEOUT: Determines the time interval (in minutes) after which the backup process stops waiting for the DR group write history log (DR group log) found in the "copying" state to move to the "not in use" state. Backup process skips the source virtual disks (in case of the source virtual disks backup) or the destination virtual disks (in case of the destination virtual disks backup) belonging to the DR groups whose log is in the "copying" state, and continues with backup of other objects specified in a ZDB backup specification.

Default: 15 minutes.

EVACA_MERGINGSTATE_TIMEOUT: Determines the time interval (in minutes) after which the backup process stops waiting for the DR group write history log (DR group log) found in the "merging" state to move to the "not in use" state. Backup process skips the source virtual disks (in case of the source virtual disks backup) or the destination virtual disks (in case of the destination virtual disks backup) belonging to the DR groups whose log is in the "merging" state, and continues with backup of other objects specified in a ZDB backup specification.

Default: 15 minutes.

SMISA_BACKUPPREPARE_RETRY: Determines the number of the HPE P6000 / HPE 3PAR SMI-S Agent queries checking for completion of container allocation or creation and setting the write cache policy on the source volumes to the write-through mode during zero downtime backup sessions. If the operations do not complete by the time the last query is made, the HPE P6000 / HPE 3PAR SMI-S Agent aborts the currently running session.

Default: 10 queries.

SMISA_BACKUPPREPARE_DELAY: Determines the interval (specified in seconds) between the HPE P6000 / HPE 3PAR SMI-S Agent queries checking for completion of container allocation or creation and setting write cache policy on the source volumes to the write-through mode during zero downtime backup sessions.

Default: 120 seconds.

SMISA_CONTAINERCREATION_RETRY: Determines the number of the HPE P6000 / HPE 3PAR SMI-S Agent queries checking for completion of container allocation or creation during instant recovery sessions. If the operation does not complete by the time the last query is made, the HPE P6000 / HPE 3PAR SMI-S Agent aborts the currently running session.

Default: 10 queries.

SMISA_CONTAINERCREATION_DELAY: Determines the interval (specified in seconds) between the HPE P6000 / HPE 3PAR SMI-S Agent queries checking for completion of container allocation or creation during instant recovery sessions.

Default: 120 seconds.

SMISA_MSGWAITING_INTERVAL: Determines the interval (specified in seconds) between session messages reporting the progress of container allocation or creation during zero downtime backup and instant recovery sessions, between session messages reporting the progress of setting the write cache policy on the source volumes to the write-through mode during zero downtime backup sessions, and between session messages reporting the progress of deleting storage volumes from the disk array.

Default: 300 seconds.

SMISA_CHECKFORABORT_DELAY: Many operations that the HPE P6000 / HPE 3PAR SMI-S Agent triggers are long-lasting. During the wait for their completion, the agent periodically checks whether an abort request was issued. This option determines the interval (specified in seconds) between each pair of checks for the abort request.

Default: 2 seconds.

SMISA_FORCE_DISMOUNT: On Windows Server 2008 systems, determines whether the Data Protector HPE P6000 / HPE 3PAR SMI-S Agent performs forced dismount of the volumes which are locked by the Windows system processes and cannot be dismounted using the ordinary dismount operation. You can enable forced dismount operation by setting this option to 1.

Default: 0 (disabled). Possible: 0|1.

ZDB_DONOT_PRESENT_DISKS: During ZDB-to-disk sessions, if this option is set to 1, the HPE P6000 / HPE 3PAR SMI-S Agent does not present volumes to the backup system. ZDB-to-disk+tape and ZDB-to-tape sessions are not affected by the option.

Default: 0 (disabled). Possible: 0|1.

ZDB_SKIP_LOCK_AT_DISMOUNT: On Windows systems, the HPE P6000 / HPE 3PAR SMI-S Agent locks the volumes on the application system prior to dismounting them. If this option is set to 1, the volumes do not get locked. Other operating systems are not affected by the option.

Default: 0 (disabled). Possible: 0|1.

EVA_CIMOM_CONNECTION_TIMEOUT: Determines the interval (specified in seconds) for which the HPE P6000 / HPE 3PAR SMI-S Agent waits for a response to an outstanding request from the CIMOM.

Default: 900 seconds.

EVA_CIMOM_QUERY_RETRIES: CIMOM operations include communication over the network and may fail unexpectedly. This option determines the maximum number of retried attempts the HPE P6000 / HPE 3PAR SMI-S Agent performs if the CIMOM returns an unexpected response.

Default: 10 attempts.

EVA_CIMOM_QUERY_INTERVAL: Determines the interval (specified in seconds) between each pair of attempts, whose maximum number is defined by EVA_CIMOM_QUERY_RETRIES.

Default: 10 seconds.

SMISA_ENFORCE_MULTISNAP: Determines how Data Protector behaves in either of the following cases:

- multisnapping is not supported by the current P6000 EVA Array configuration
- disk array limitation on the number of source disks that can be involved in multisnapping is exceeded
- source disks are located on more than one P6000 EVA Array storage system

If multisnapping is enforced by SMISA_ENFORCE_MULTISNAP, the zero downtime backup session is aborted.

If multisnapping is not enforced, Data Protector creates target volumes sequentially (in the first case) or attempts to create target volumes with several multisnapping operations instead of only one (in the other two cases).

Note that SMISA_ENFORCE_MULTISNAP should not be used to enforce multisnapping in zero downtime backup sessions for backing up the Oracle Server data in ASM configurations, since the HPE P6000 / HPE 3PAR SMI-S Agent detects such sessions automatically.

Default: 0 (multisnapping not enforced). Possible: 0|1.

SMISA_WAIT_MIRRORCLONE_PENDING_TIMEOUT: Determines the time period (specified in minutes) for which the HPE P6000 / HPE 3PAR SMI-S Agent waits for the mirrorclone link to transition from some other state into the synchronized state. If the time period expires before the mirrorclone link gets into the synchronized state, the HPE P6000 / HPE 3PAR SMI-S Agent aborts the session. The option affects only the zero downtime backup sessions for which the selected snapshot source is mirrorclone.

Default: 60 minutes.

SMISA_WAIT_MIRRORCLONE_PENDING_RETRY: Determines the interval (specified in seconds) between each pair of checks of the mirrorclone link state when waiting for the link to transition into the synchronized state. The option affects only the zero downtime backup sessions for which the selected snapshot source is mirrorclone.

Default: 30 seconds.

P9000 XP Array specific options

This section explains P9000 XP Array-specific omnirc options.

See also "[Common ZDB options](#)" on page 248.

ZDB_BACKUP_VG_EXIST: On HP-UX platform, for systems configured with multiple HBAs and connections to a disk array, the alternate paths solution performs dynamic load balancing. By default, during preparation for backup and restore, Data Protector creates a volume group with the disk on the first HBA as the primary path.

To disable volume group autoconfiguration on the backup host and load balance the data across multiple paths manually, set this option to 1. The existing backup volume group will be used in the next backup or restore session.

Note: If this option is set, volume groups are not removed from `/etc/lvmtab` on the backup system after each backup. For more information, see "[Backup options](#)" on page 92.

Default: 0.

OB2AUTOPATH_BALANCING_POLICY: Determines the HPE AutoPath load balancing policy used.

AutoPath provides enhanced data availability for systems configured with multiple host adapters and connections to a disk array. When several alternate paths are available, AutoPath dynamically balances data load between the alternate paths to achieve optimum performance.

Possible values are:

- 0 [none] – No policy
- 1 [RR] – Round Robin policy (default)
- 2 [SQL] – Shortest Queue Length policy

During a ZDB-to-tape session, if the AutoPath Shortest Queue Length load balance policy is set and failover to an alternate path occurs, the session is aborted.

- 3 [SST] – Shortest Service Time policy

For more information, see the AutoPath documentation.

SSEA_SPLIT_REPORT_RATE: During the split, the HPE P9000 XP Agent checks the status of mirrored disks within an interval determined by `SSEA_SPLIT_SLEEP_TIME` for the number of times determined by `SSEA_SPLIT_RETRY`.

`SSEA_SPLIT_REPORT_RATE` determines the frequency of displaying the mirrored disks' status to the Data Protector Monitor. For example, if `SSEA_SPLIT_SLEEP_TIME` is 2 seconds and `SSEA_SPLIT_REPORT_RATE` is 5, the status is displayed for every fifth check (every 10 seconds).

Default: 5.

SSEA_SPLIT_RETRY: During the split, the HPE P9000 XP Agent checks the mirrored disks' status within an interval determined by `SSEA_SPLIT_SLEEP_TIME`. `SSEA_SPLIT_RETRY` determines the number of retries for the checks. If there is no progress after that, the split is aborted.

Default: 120 retries.

SSEA_SPLIT_SLEEP_TIME: During the split, the HPE P9000 XP Agent checks the mirrored disks status for the number of times determined by SSEA_SPLIT_RETRY. SSEA_SPLIT_SLEEP_TIME determines the time interval between the status checks.

Default: 2 seconds.

SSEA_SYNC_REPORT_RATE: During the disks' resynchronization, the HPE P9000 XP Agent checks the mirrored disks' status within an interval determined by SSEA_SYNC_SLEEP_TIME for the number of times determined by SSEA_SYNC_RETRY.

SSEA_SYNC_REPORT_RATE determines the rate of displaying the mirrored disks status. For example, if SSEA_SYNC_SLEEP_TIME is 5 seconds and SSEA_SYNC_REPORT_RATE is 2, the status is displayed for every second check (every 10 seconds).

Default: 2.

SSEA_SYNC_RETRY: During the disks' resynchronization, the HPE P9000 XP Agent checks the mirrored disks' status within an interval specified by SSEA_SYNC_SLEEP_TIME. SSEA_SYNC_RETRY determines the number of retries for these checks. If there is no progress after that, the resynchronization is aborted.

Default: 10 retries.

SSEA_SYNC_SLEEP_TIME: During the disks' resynchronization, the HPE P9000 XP Agent checks the mirrored disks' status for the number of times determined by SSEA_SYNC_RETRY. SSEA_SYNC_SLEEP_TIME determines the time interval between the status checks.

Default: 5 seconds.

SSEA_WAIT_PAIRS_PROPER_STATUS: All disk pairs must be in proper status (either STAT_PSUS/SSUS or STAT_PAIR) before a process continues. This option determines the maximum waiting period for disk pairs to change to proper status.

SMB_SCAN_RDSK_TIMEOUT: On Windows, during backup system preparation, the system is scanned for new devices. When new devices are detected, they appear on the backup system as new physical drives. This option sets the maximum time (in seconds) for which a ZDB Agent on the backup system waits for a new physical drive to appear.

Default: 30 seconds. Usually, it is sufficient, unless there are configuration problems on the backup system.

SMB_SCAN_FOR_VOLUME_TIMEOUT: On Windows, sets the maximum time (in seconds) for which a ZDB Agent on the backup system waits for new volumes to appear on the backup system. This happens after a physical drive is detected during backup system preparation.

Default: 300 seconds. Usually, it is sufficient, unless there are configuration problems on the backup system.

Default: 120 minutes.

SSEA_FORCE_DISMOUNT: On Windows Server 2008 systems, determines whether the HPE P9000 XP Agent will perform forced dismount of the volumes which are locked by the Windows system processes and cannot be dismounted using the ordinary dismount operation. You can enable forced dismount operation by setting this option to 1.

Default: 0 (disabled). Possible: 0|1.

MAXIMUM_HOST_LOCKING_RETRY: The HPE P9000 XP Agent will lock the backup system during the backup system preparation. The lock operation may fail due to concurrent ZDB sessions or

similar actions. This option determines the maximum number of attempts by the HPE P9000 XP Agent at locking the backup system.

Default: 60 attempts.

SSEA_ATTACH_RETRY: Prior to manipulating volumes on a disk array, the HPE P9000 XP Agent must connect to an appropriate command device. In case of a problem with the SAN connectivity, establishing such a connection may fail. This option determines the number of attempts made by the HPE P9000 XP Agent at connecting to the command device.

Default: 5 attempts.

SSEA_ATTACH_SLEEP_TIME: Determines the interval (specified in seconds) between each pair of attempts of HPE P9000 XP Agent at connecting to the command device.

Default: 10 seconds.

EMC specific options

This section explains EMC-specific `omnirc` options.

See also "[Common ZDB options](#)" on page 248.

SYMA_LOCK_RETRY, SYMA_SLEEP_FOR_LOCK: Each time EMC Agent calls the WideSky library, it initiates the WideSky session, which locks the EMC Symmetrix database file. Other sessions must wait to get the lock.

Default: 15 retries, 30 seconds sleep time.

SYMA_SYNC_RETRY, SYMA_SLEEP_FOR_SYNC: To successfully split the disks, EMC Agent first checks the links' status (links can be split only after all devices are synchronized).

Default: 15 retries, 30 seconds sleep time.

These two options are also used for incremental restore of device groups. EMC Agent starts the incremental restore only when there are no write pending tracks to devices in the restore device group.

Default: 15 retries; checking the number of write pending track - every 30 seconds.

SYMA_REC_FILE_LIMIT: Invalid records are automatically deleted when the EMC Agent recovery file exceeds a certain size.

Default: 102400 bytes.

SYMA_MOUNT_R2_READWRITE:

Determines the mode in which volume groups and filesystems are activated and mounted:

- 0: read-only mode (default)
- 1: read/write mode

For backup, it is sufficient to activate volume groups and filesystems in read-only mode. If you use the mirror for DSS or other tasks after backup, this may not be sufficient.

SYMA_UMOUNT_BEFORE_SPLIT:

Determines whether filesystems on the application system are dismounted before the split:

- 0: not dismounted (default)
- 1: dismounted before the split, remounted after (to ensure filesystem data is consistent)

A filesystem does not have a stop I/O to flush data from the filesystem cache to disk and stop I/O during the split. The only way to back up filesystems in split mirror mode is to dismount the mount point on the application system. If applications run on the filesystem, they control I/O to the disk. In this case, it is not necessary to dismount the filesystem before the split.

User scenarios - examples of ZDB options

This section gives examples of backup policies with appropriate ZDB options.

P6000 EVA Array integration

Example 1

ZDB to tape must be performed once a day (during the night). During the day, three copies must be available for instant recovery.

To implement such policy:

- Select **Track the replica for instant recovery**.
- Set **Number of replicas rotated** to 3.
- Select the desired snapshot source.
- Select the desired snapshot type.
- Select **Same as source** for the redundancy level.

The following option is selected automatically:

- **Keep the replica after the backup**

Then, schedule the ZDB backup specification to start three ZDB-to-disk sessions during the day and one ZDB-to-disk+tape session during the night.

Example 2

ZDB to tape must be performed every three hours. Replicas created are used for data mining (not for instant recovery) for the time period of three hours.

To implement such policy:

- Clear **Track the replica for instant recovery**.
- Select **Keep the replica after the backup**.
- Set **Number of replicas rotated** to 1.
- Select the desired snapshot source.
- Select the desired snapshot type.
- Select **Leave the backup system enabled**.
- On UNIX systems, optionally select **Enable the backup system in read/write mode**.
- Set the `omnirc` option `ZDB_ORA_INCLUDE_CF_OLF` to 1. For more information, see the *HPE Data Protector Zero Downtime Backup Integration Guide*.

Then, schedule the ZDB backup specification to start one ZDB-to-tape session every three hours.

Example 3

ZDB to tape must be performed every three hours. The replica created must be available for instant recovery for 12 hours.

To implement such policy:

- Select **Track the replica for instant recovery**.
- Set **Number of replicas rotated** to 4.
- Select the desired snapshot source.
- Select the desired snapshot type.
- Select **Same as source** for the redundancy level.

The following option is selected automatically:

- **Keep the replica after the backup**

Then, schedule the ZDB backup specification to start eight ZDB-to-disk+tape sessions every three hours.

P9000 XP Array integration

Example 1

A replica set is configured, with all replicas available for instant recovery. The next replica must be prepared according to replica set rotation after zero downtime backup and forcibly synchronized before the next zero downtime backup.

To implement such policy, select the following options:

- **Track the replica for instant recovery**
- **Synchronize the disks if not already synchronized**
- **Prepare the next mirror disks for the backup (resynchronize)**

The following option is selected automatically:

- **Keep the replica after the backup**

Example 2

A replica set is configured, with all replicas available for offline data processing after the ZDB session. The next replica must be prepared according to replica set rotation after the zero downtime backup, and the next ZDB session must be aborted if data processing is not finished.

Note: This example assumes that offline data processing involves splitting links before data processing and resynchronizing links afterwards.

To implement such policy, select the following options:

- **Keep the replica after the backup**
- **Abort the session if the mirror disks are not synchronized**
- **Prepare the next mirror disks for the backup (resynchronize)**
- **Leave the backup system enabled**

Example 3

A replica set is configured, with versions on replicas available for on-demand offline data processing (links are split on demand and the backup system is prepared for offline data processing manually), but not for instant recovery. The replica must be prepared at the start of a ZDB session.

To implement such policy:

- Select **Synchronize the disks if not already synchronized**.
- Clear **Keep the replica after the backup**.

Example 4

A single replica is configured, with the version on the replica available for offline data processing. The replica must be prepared at the start of a ZDB session.

To implement such policy, select the following options:

- **Keep the replica after the backup**
- **Synchronize the disks if not already synchronized**
- **Leave the backup system enabled**

Conflicting Options

If a single replica is configured and the following options are selected, the second option is ignored, since the replica to be kept is at the same time the replica to be prepared for the next zero downtime backup:

- **Keep the replica after the backup**
- **Prepare the next mirror disks for the backup (resynchronize)**

Note: A conflict may also occur when a replica set is configured, depending on the replica set selection and the P9000 XP LDEV exclude file.

EMC integration

Example 1

After zero downtime backup, the replica must be discarded and prepared for the next zero downtime backup at the end of the ZDB session.

To implement such backup policy:

- Select **Re-establish links after backup**.
- Do not select **Re-establish links before backup**.

Example 2

After zero downtime backup, the replica must be used for offline data processing and prepared at the start of the next ZDB session.

To implement such backup policy:

- Select **Re-establish links before backup**.
- Do not select **Re-establish links after backup**.

Backup system mount point creation

Data Protector disk array integrations support configurations where multiple application systems are connected to a disk array and one system (the backup system) is responsible for backing up these applications. Local, remote, or remote plus local replication configuration (if supported on a particular array) can be used for ZDB in such a configuration. For more information on supported configurations, see the *HPE Data Protector Concepts Guide*.

Each application system uses its own original storage, from which replicas are created; in case of ZDB to tape and ZDB to disk+tape, filesystems are mounted on the backup system.

Filesystem and Microsoft Exchange Server backup

To perform a concurrent backup of multiple application systems, the mount points assigned to the filesystems in the original storage *do not need to be* different for each application system. The backup of the Microsoft Exchange Server application is performed as *filesystem* backup. With filesystem backup, Data Protector, during a ZDB session, creates or reuses unique mount points on the backup system. Data Protector then mounts filesystems to these mount points.

Backup system mount point creation: filesystem and Microsoft Exchange Server backup

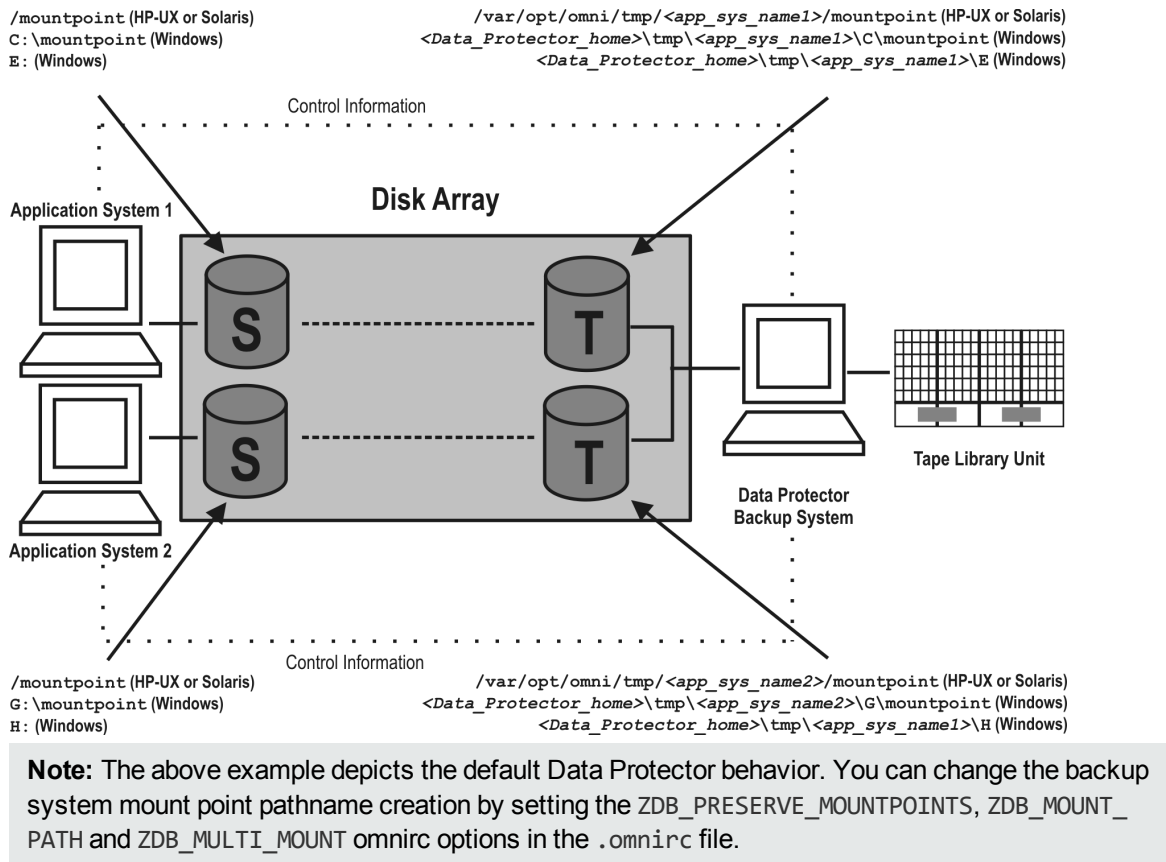

Application and disk image backup

The information in this section applies only for the backup of the following:

- Disk images
- Oracle
- SAP R/3
- Microsoft SQL Server

For a list of applications, supported for a particular type of a disk array, see the HPE Data Protector Product Announcements, Software Notes, and References.

Applications on filesystems

To perform a concurrent backup of multiple application systems, the mount points or drive letters assigned to the original storage *must be* different for each application system. Data Protector, during a ZDB session, creates mount points or drive letters with the same names as on the application system. Data Protector then mounts filesystems in a replica to these mount points.

If the mount points or drive letters are the same for different application systems, concurrent backup of such systems is not possible; backup of objects that belong to these mount points or drive letters must be run sequentially.

Applications on disk images + disk image backup

If your application uses disk images as the data source, or if you are performing a disk image backup without an application, the following applies: Data Protector, during a ZDB session, finds and uses raw device files (UNIX systems) or physical drive numbers (Windows systems) for the replica created from the original storage raw device files (UNIX systems) or physical drive numbers (Windows systems) on the backup system. Therefore, make sure the device file names and physical drive numbers are the same on the application and the backup systems.

Note that due to the limitation described above, snapshot integrations are not suitable for such backups (with snapshot integrations, Data Protector cannot guarantee that after presentation to the backup system replicas are assigned the same raw device files or physical drive numbers as on the application system).

Note: With the HPE P9000 XP Disk Array Family, if the HPE Business Copy (BC) P9000 XP first-level mirrors or snapshot volumes are configured, the integration always mounts the selected first-level mirror or snapshot volume to the same mount point.

Backup system mount point creation: application or disk image backup

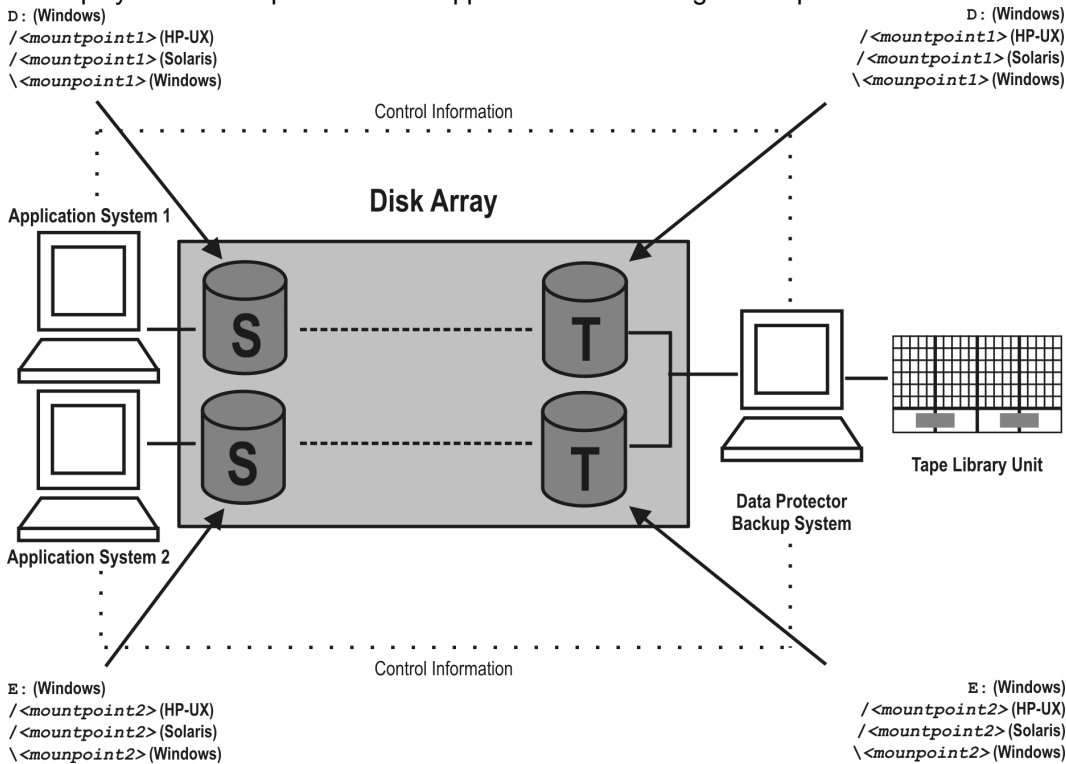

EMC Symmetrix—obtaining disk configuration data

Obtaining disk information is necessary during installation and configuration. The examples below describe choosing and checking EMC devices (disks) for the correct connection type (TimeFinder, SRDF, SRDF+TimeFinder).

To check if the EMC configuration is correct, execute:

- `syminq` to display disk type (blank, R1, R2, or BCV).
- `symbcv list` to display SLD-BCV pairs.
- `symrdf list` to display RDF1 - RDF2 pairs.

Example 1

The application system is connected to Primary (R1) Symmetrix and the backup system to Secondary (R2) Symmetrix. Disks 008 and 009 on the application system can be used for SRDF or SRDF+TimeFinder. To verify the configuration:

1. Execute `syminq` on the application system and search for disk numbers in the `Ser Num` column.

Device			Product		Device	
Name	Type	Vendor	ID	Rev	Ser Num	Cap (kB)
HP-UX systems: /dev/rdisk/c1t9d1 Or /dev/rdisk/disk425 Windows systems: \\.\PHYSICALDRIVE1	R1	EMC	SYMMETRIX	5264	87008150	2817120
HP-UX systems: /dev/rdisk/c1t9d2 Or /dev/rdisk/disk426 Windows systems: 	R1	EMC	SYMMETRIX	5264	87009150	2817120

From the `Type` column, you see that the disks are R1 (required for SRDF and SRDF+TimeFinder).

2. To check if the disks have the same serial number on the backup system, execute `symrdf list` on the backup system.

Local device view									
Status modes					RDF states				
Sym Dev	Rdev	RDF Typ:D	SA RA LNK	Mode Dom ACp	R1 Inv Tracks	R2 Inv Tracks	Dev	Rdev	Pair
008	008	R2:1	RW WD RW	SYN DIS OFF	0	0	WD	RW	Synch
009	009	R2:1	RW WD RW	SYN DIS OFF	0	0	WD	RW	Synch

You see from the first two columns that the disks have the same numbers on both hosts.

3. Query additional information by executing `syminq` and look for disks 008 and 009.
4. If you have SRDF+TimeFinder:
 - a. Execute `symbcv list` on the backup system to find associated BCVs.

BCV device				Standard device		Status	
Physical	Sym	RDF Att.	Inv. Tracks	Physical	Sym	Inv Tracks	BCV<=>STD
HP-UX systems: c1t8d0 Or disk395 Windows systems: DRIVE5	038	+	0	HP-UX systems: c1t1d0 Or disk496 Windows systems: Not Visible	008	0	Synch
HP-UX systems: c1t8d1 Or disk396 Windows systems: DRIVE6	039	+	0	HP-UX systems: c1t1d1 Or disk497 Windows systems: Not Visible	009	0	Synch

You can see which BCV belongs to which SLD. The first four columns contain information about BCVs, the last four about SLDs.

- b. To ensure that the disks are correct, execute `syminq` on the backup system and search for BCVs under disk numbers 038 and 039. The disk you find should be BCV.

Device			Product		Device	
Name	Type	Vendor	ID	Rev	Ser Num	Cap (kB)
HP-UX systems: /dev/rdsl/c1t8d0 Or /dev/rdisk/disk395 Windows systems: \\PHYSICALDRIVE5	BCV	EMC	Symmetrix	5264	87038150	N/A
HP-UX systems: /dev/rdsl/c1t8d1 Or /dev/rdisk/disk396 Windows systems: \\PHYSICALDRIVE6	BCV	EMC	Symmetrix	5264	87039150	N/A

Example 2

Both application and backup systems are connected to the same EMC. Disks 048 and 049 on the application system can be used for TimeFinder. To check the configuration:

1. Execute `syminq` on the application system and search for disk numbers in the `Ser Num` column.

Device			Product		Device	
Name	Type	Vendor	ID	Rev	Ser Num	Cap (kB)
HP-UX systems: /dev/rdisk/c0t0d0 Or /dev/rdisk/disk123 Windows systems: \\.\PHYSICALDRIVE1		EMC	Symmetrix	5264	87048150	2817120
HP-UX systems: /dev/rdisk/c0t0d1 Or /dev/rdisk/disk124 Windows systems: 		EMC	Symmetrix	5264	87049150	2817120

From the `Type` column, you see that the disk type is blank. However, it may also be R1 or R2, and the disks must have associated BCVs. These are all requirements for TimeFinder configurations.

2. Execute `symbcv list` on the backup system and find your disk there.

BCV Device				Standard device		Status	
Physical	Sym	RDF att.	Inv Tracks	Physical	Sym	Inv Tracks	BCV<=>STD
HP-UX systems: c0t5d0 Or disk500 Windows systems: 	028	+	0	HP-UX systems: c0t10d0 Or disk200 Windows systems: Not Visible	048	0	Synch
HP-UX systems: c0t5d1 Or disk501 Windows systems:	029	+ p	0	HP-UX systems: c0t10d1 Or disk2001 Windows systems:	049	0	Synch

BCV Device				Standard device		Status	
Physical	Sym	RDF att.	Inv Tracks	Physical	Sym	Inv Tracks	BCV<=>STD
DRIVE14				Not Visible			

You can see which BCV belongs to which SLD. The first four columns contain information about BCVs, the last four about SLDs

You can double-check BCV by executing `syminq` on the backup system. The disk you find should be BCV.

Device			Product		Device	
Name	Type	Vendor	ID	Rev	Ser Num	Cap (kB)
HP-UX systems: /dev/rdisk/c0t5d0 Or /dev/rdisk/disk500 Windows systems: \\.\PHYSICALDRIVE5	BCV	EMC	Symmetrix	5264	17028150	2817120
HP-UX systems: /dev/rdisk/c0t5d1 Or /dev/rdisk/disk501 Windows systems: \\.\PHYSICALDRIVE6	BCV	EMC	Symmetrix	5264	17029150	2817120

Additional information for troubleshooting

HP-UX systems

To identify physical devices belonging to a particular volume group, execute:

On the application system:

- `strings /etc/lvmtab`
All volume groups and devices belonging to volume groups are displayed.
- `vgdisplay -v /dev/VG_name`
Logical volumes and devices for a specified volume group are displayed.

On the backup system:

- `/usr/symcli/bin/symdg list`
Device group names and additional information about devices is displayed.
- `/usr/symcli/bin/symdg show DgName`
Detailed information about devices and associated BCVs is displayed.

Windows systems

Execute `symntctl` with additional parameters to get information about disks, signatures, and drives. For more information, see the EMC documentation.

On the backup system, execute:

- `symdg list` to display device group names and additional information about devices.
- `symdg show DgName` to display detailed information about devices and associated BCVs.

Send Documentation Feedback

If you have comments about this document, you can [contact the documentation team](#) by email. If an email client is configured on this system, click the link above and an email window opens with the following information in the subject line:

Feedback on Zero Downtime Backup Administrator's Guide (Data Protector 9.09)

Just add your feedback to the email and click send.

If no email client is available, copy the information above to a new message in a web mail client, and send your feedback to AutonomyTPFeedback@hpe.com.

We appreciate your feedback!