



# HP Operations Manager

Software Version: 9.21  
HP-UX 11i v3 on HP Integrity

## Installation Guide

Document Release Date: March 2017  
Software Release Date: March 2016

## Legal Notices

### Warranty

The only warranties for HP products and services are set forth in the express warranty statements accompanying such products and services. Nothing herein should be construed as constituting an additional warranty. HP shall not be liable for technical or editorial errors or omissions contained herein.

The information contained herein is subject to change without notice.

### Restricted Rights Legend

Confidential computer software. Valid license from HP required for possession, use or copying. Consistent with FAR 12.211 and 12.212, Commercial Computer Software, Computer Software Documentation, and Technical Data for Commercial Items are licensed to the U.S. Government under vendor's standard commercial license.

### Copyright Notice

© Copyright 1993–2017 Hewlett-Packard Development Company, L.P.

### Trademark Notices

Adobe® and Acrobat® are trademarks of Adobe Systems Incorporated.

HP-UX Release 10.20 and later and HP-UX Release 11.00 and later (in both 32 and 64-bit configurations) on all HP 9000 computers are Open Group UNIX 95 branded products.

Intel®, Itanium®, and Pentium® are trademarks of Intel Corporation in the U.S. and other countries.

Java is a registered trademark of Oracle and/or its affiliates.

Microsoft® and Windows® are U.S. registered trademarks of Microsoft Corporation.

Oracle is a registered trademark of Oracle and/or its affiliates.

UNIX® is a registered trademark of The Open Group.

## Documentation Updates

The title page of this document contains the following identifying information:

- Software Version number, which indicates the software version.
- Document Release Date, which changes each time the document is updated.
- Software Release Date, which indicates the release date of this version of the software.

To check for recent updates or to verify that you are using the most recent edition of a document, go to:

**<https://softwaresupport.hp.com>**

This site requires that you register for an HP Passport and sign in. To register for an HP Passport ID, go to:

**<https://hpp12.passport.hp.com/hppcf/createuser.do>**

Or click the **the Register** link at the top of the HP Software Support page.

You will also receive updated or new editions if you subscribe to the appropriate product support service. Contact your HP sales representative for details.

## Support

Visit the HP Software Support Online web site at: **<https://softwaresupport.hp.com>**

This web site provides contact information and details about the products, services, and support that HP Software offers.

HP Software online support provides customer self-solve capabilities. It provides a fast and efficient way to access interactive technical support tools needed to manage your business. As a valued support customer, you can benefit by using the support web site to:

- Search for knowledge documents of interest
- Submit and track support cases and enhancement requests
- Download software patches
- Manage support contracts
- Look up HP support contacts
- Review information about available services
- Enter into discussions with other software customers
- Research and register for software training

Most of the support areas require that you register as an HP Passport user and sign in. Many also require a support contract. To register for an HP Passport ID, go to:

**<https://hpp12.passport.hp.com/hppcf/createuser.do>**

To find more information about access levels, go to:

**<https://softwaresupport.hp.com/web/softwaresupport/access-levels>**

**HP Software Solutions Now** accesses the HPSW Solution and Integration Portal Web site. This site enables you to explore HP Product Solutions to meet your business needs, includes a full list of Integrations between HP Products, as well as a listing of ITIL Processes. The URL for this Web site is

**<http://h20230.www2.hp.com/sc/solutions/index.jsp>**

# Contents

Chapter 1: Installation Requirements for the Management Server .....	13
In This Chapter .....	13
HPOM Installation and Upgrade Tasks .....	13
Verifying Installation Requirements .....	15
Hardware Requirements .....	16
Required Disk Space .....	16
Required RAM and Swap Space .....	17
Performance Requirements .....	19
Intersystem Connection Requirements .....	19
Software Requirements .....	20
Operating System .....	20
Kernel Parameters .....	20
Operating System and Environment Patches .....	22
Administration UI Requirements .....	22
Previous Configuration Value Pack (CVP) Version .....	22
Passwords .....	22
HPOM Database Settings .....	23
Updating the Administration UI When Modifying the Database Path .....	23
Web Browser Support .....	23
HPOM Database Configuration .....	24
Database Passwords .....	24
Supported Agent Versions .....	24
Chapter 2: Installing and Configuring HPOM on the Management Server .....	25
In This Chapter .....	25
Before Installing and Configuring HPOM .....	25
Configuring Input/Output for Multiple Language Support .....	26
Installing and Configuring HPOM .....	27
Installing an Oracle Database .....	27
Required Oracle Products .....	28
Using an Existing Oracle Database .....	28
Before Installing an Oracle Database .....	29

Preparation Steps .....	31
Installing Oracle Database 11g Release 1 .....	32
Installing Oracle Database 11g Release 2 .....	33
Installing Oracle Database 12c .....	37
Installing a PostgreSQL Database .....	41
Required PostgreSQL Products .....	41
Before Installing a PostgreSQL Database .....	41
Installing a PostgreSQL Database .....	41
Installing PostgreSQL Server Binaries .....	42
Preparing HPOM to Use the PostgreSQL Database .....	42
Creating and Configuring a Database Cluster .....	43
Installing and Configuring the HPOM Software on the Management Server System .....	43
Usage of the ovininstall and ovoconfigure Scripts .....	44
Before Running ovininstall .....	45
Preparing for the HPOM Software Installation and Configuration from a DVD-ROM .....	45
Installing and Configuring the HPOM Software on the Management Server .....	46
Configuring an Oracle Database .....	53
Configuring a PostgreSQL Database .....	55
Managed PostgreSQL Database .....	56
PostgreSQL Cluster Directory Is Empty or Non-Existent .....	56
PostgreSQL Cluster Directory Belongs To an HPOM-created Cluster .....	57
Independent PostgreSQL Database .....	58
Viewing the Installation Log Files .....	59
Administration UI Installation Log File .....	59
Starting HPOM and Verifying the Installation .....	59
Creating Additional Database Users .....	62
Oracle Database Users .....	62
PostgreSQL Database Users .....	62
Reconfiguring the HPOM Software .....	63
Reconfiguring Database Connection Parameters .....	63
Changing a Database Password .....	64
Changing an Oracle Database Password .....	64
Changing a PostgreSQL Database Password .....	65
Reconfiguring HPOM to Work with a New Database Name .....	66
 Chapter 3: Installing the Java GUI .....	 67

- In This Chapter ..... 67
- Supported Platforms ..... 67
  - Supported Languages ..... 68
- Installation Requirements ..... 69
  - Hardware Requirements ..... 69
  - Software Requirements ..... 69
  - Supported Web Browsers ..... 70
- Installing the Java GUI ..... 71
  - Installing the Java GUI Through HTTP ..... 71
  - Installing the Java GUI Through FTP ..... 71
  - Installing the Java GUI from the Installation Media ..... 72
- Starting the Java GUI ..... 73
  - ito\_op Startup Script ..... 74
  - Starting the Java GUI on a Windows System ..... 74
  - Starting the Java GUI on a UNIX-based System ..... 74
  - Starting the Java GUI from a Web Browser ..... 75
  - Connecting Through a Firewall ..... 75
- Configuring the HTTP Server ..... 75
  - Configuring a Netscape Web Server ..... 76
  - Configuring a W3C Jigsaw Web Server ..... 76
- Chapter 4: Service Management and Database Configuration ..... 77**
  - In This Chapter ..... 77
  - Starting and Stopping HPOM ..... 77
  - Starting and Stopping a Database Automatically ..... 78
    - Starting and Stopping an Oracle Database Automatically ..... 78
    - Starting and Stopping a PostgreSQL Database Automatically ..... 79
  - Starting and Stopping a Database Manually ..... 79
    - Starting and Stopping an Oracle Database Manually ..... 79
      - Starting an Oracle Database Manually ..... 79
      - Stopping an Oracle Database Manually ..... 80
    - Starting and Stopping a PostgreSQL Database Manually ..... 81
      - Starting a PostgreSQL Database Manually ..... 81
      - Stopping a PostgreSQL Database Manually ..... 81
  - Native Language Support in a Database ..... 82

Oracle Database Character Set .....	82
PostgreSQL Database Character Set .....	83
Environment Variables in an Oracle Database .....	83
Alternative Database Locations .....	84
Replacing an HPOM Database .....	84
Setting Up HPOM with a Remote/Manual Oracle Database .....	86
Checking System Requirements .....	86
Recognizing Limitations During the HPOM Runtime .....	86
Preparation Steps .....	87
Creating and Configuring an HPOM Database on a Database Server .....	87
Creating and Configuring Oracle Database 11g .....	88
Creating and Configuring Oracle Database 12c .....	91
Configuring Users, Passwords, and User Rights Manually .....	93
Configuring Access to the HPOM Database .....	95
Syntax Examples for the .ora Files .....	95
Installing and Configuring HPOM with a Remote/Manual Oracle Database .....	96
Setting Up HPOM with a Remote/Manual PostgreSQL Database .....	98
Checking System Requirements .....	99
Recognizing Limitations During the HPOM Runtime .....	99
Creating and Configuring a PostgreSQL Database Cluster .....	99
Creating and Configuring a PostgreSQL Database Cluster by Using the psqlcluster Tool .....	100
Creating and Configuring a PostgreSQL Database Cluster Manually .....	101
Installing and Configuring HPOM with a Remote/Manual PostgreSQL Database .....	104
Setting Up HPOM in an Oracle Real Application Clusters (RAC) Environment .....	107
Checking System Requirements .....	108
Recognizing Limitations During the HPOM Runtime .....	108
Installing Oracle RAC .....	109
Preparation Steps .....	109
Creating and Configuring the HPOM Database on Cluster Nodes .....	109
Creating and Configuring Oracle Database 11g .....	110
Creating and Configuring Oracle Database 12c .....	114
Configuring Users, Passwords, and User Rights Manually .....	115
Configuring Access to the HPOM Database .....	117
Syntax Examples for the .ora Files .....	119
Installing and Configuring HPOM in an Oracle RAC Environment .....	121

Configuring the Administration UI for Oracle RAC .....	122
<b>Chapter 5: Directory Structure on the Management Server .....</b>	<b>124</b>
In This Chapter .....	124
HPOM File Tree on the Management Server .....	124
System Resources Adapted by HPOM .....	128
<b>Chapter 6: Software Administration on the Management Server .....</b>	<b>129</b>
In This Chapter .....	129
Deinstalling HPOM .....	129
Deinstalling the Java GUI .....	131
Deinstalling the Java GUI from a Windows Client .....	131
Deinstalling the Java GUI from an HP-UX 11i Client .....	132
Deinstalling the Java GUI from Other UNIX-based Systems .....	132
Reinstalling HPOM .....	132
Reinitializing the HPOM Database and Configuration .....	134
Reinstalling the Administration UI .....	135
<b>Chapter 7: Migrating HPOM from One System to Another .....</b>	<b>137</b>
In This Chapter .....	137
Verifying Installation Requirements for the Management Server .....	137
Migration Scenarios .....	138
Migration to a System with a Different IP Address and Hostname .....	138
Downloading the Old Server Configuration .....	139
Setting Up a New Server .....	140
Uploading the Saved HPOM Configuration .....	140
Establishing a Trust Relationship Between the Two Management Servers .....	142
Setting Up Message Forwarding Between the Management Servers .....	144
Upgrade of the Systems in a MoM Setup by Reusing the IP Addresses and Hostnames .....	146
Upgrading Systems in a MoM Setup by Reusing IP Addresses and Hostnames .....	147
<b>Chapter 8: Upgrading HPOM to Version 9.2x .....</b>	<b>150</b>
In This Chapter .....	150
Upgrading from HPOM 8.xx to HPOM 9.2x .....	150



Verifying the Installation Requirements for the Management Server .....	151
Backing Up the Current HPOM 8.xx Installation .....	151
Downloading the Current HPOM 8.xx Configuration .....	152
Converting Templates to Policies .....	153
Procedure for Downloading the Current HPOM 8.xx Configuration .....	154
Installing a New Database Version .....	154
Database Specifics .....	155
Upgrading an Old Version of HPOM .....	156
Uploading the Saved HPOM Configuration .....	158
Upgrading from HPOM 9.1x to HPOM 9.2x .....	160
Verifying Installation Requirements for the Management Server .....	160
Upgrading HPOM from Version 9.1x to Version 9.2x .....	161
Migrating from Oracle to PostgreSQL .....	163
Upgrading an HPOM Database .....	165
Upgrading an Oracle Database .....	166
Upgrading a PostgreSQL Database .....	169
Upgrading a Minor PostgreSQL Database Version .....	169
Upgrading a Major PostgreSQL Database Version .....	171
Preparing the Administration UI to Use the New HPOM Database .....	173
Upgrading the Java GUI .....	173
Upgrading the HP Operations Agent Software .....	174
Migrating Licenses to HPOM 9.2x .....	174
Prerequisite for License Migration .....	174
Migrating Licenses .....	174
Installing License Passwords Selectively .....	175
Installing License Passwords Nonselectively .....	175
<b>Chapter 9: Managing HPOM in a Cluster Environment .....</b>	<b>176</b>
In This Chapter .....	176
Configuration Scenarios .....	176
Upgrading HPOM in a Cluster Environment .....	179
Stopping the HP Operations Management Server in a Cluster Environment for Maintenance .....	179
Deinstalling HPOM from Cluster Nodes .....	180
Deinstalling HPOM from Passive Cluster Nodes .....	181
Deinstalling HPOM from the Active Cluster Node .....	181

Chapter 10: Installing HPOM in an HP ServiceGuard Environment .....182

- In This Chapter .....182
- Installation Requirements .....182
- Installing and Configuring the HP Operations Management Server in a Cluster Environment .182
- Before You Install the HP Operations Management Server on the First Cluster Node ..... 183
  - Preparation Steps for the First Cluster Node in a Basic Environment ..... 183
  - Preparation Steps for the First Cluster Node in a Decoupled Environment .....187
  - Preparation Steps for the First Cluster Node in a Cluster Environment Using an Independent Database Server ..... 191
- Before You Install the HP Operations Management Server on Additional Cluster Nodes .....193
  - Preparation Steps for Additional Cluster Nodes ..... 193
- Installing a Database Server for HPOM in a Cluster Environment .....194
  - Database Server on a Local Disk .....195
    - Basic Management Server Configuration .....195
    - Decoupled Management Server Configuration .....195
    - Independent Database Server Configuration .....196
  - Database Server on a Shared Disk (Exceptional) .....196
    - Oracle Database Server on a Shared Disk .....197
      - Basic Management Server Configuration .....197
      - Decoupled Management Server Configuration .....197
    - PostgreSQL Database Server on a Shared Disk .....198
      - Basic Management Server Configuration .....198
      - Decoupled Management Server Configuration .....198
  - Database Server on a Remote File System .....199
    - Independent Database Server Configuration .....199
- Installing and Configuring the HP Operations Management Server on Cluster Nodes .....200
  - Installing and Configuring the HP Operations Management Server on the First Cluster Node .....200
  - Installing and Configuring the HP Operations Management Server on an Additional Cluster Node .....203
- Log Files .....204

Chapter 11: Installing HPOM in a Veritas Cluster Environment .....206

- In This Chapter .....206
- Installation Requirements .....206

Installing and Configuring the HP Operations Management Server in a Cluster Environment	206
Before You Install the HP Operations Management Server on the First Cluster Node	207
Preparation Steps for the First Cluster Node in a Basic Environment	208
Preparation Steps for the First Cluster Node in a Decoupled Environment	210
Preparation Steps for the First Cluster Node in a Cluster Environment Using an Independent Database Server	214
Before You Install the HP Operations Management Server on Additional Cluster Nodes	215
Preparation Steps for Additional Cluster Nodes	215
Installing a Database Server for HPOM in a Cluster Environment	216
Database Server on a Local Disk	218
Basic Management Server Configuration	218
Decoupled Management Server Configuration	218
Independent Database Server Configuration	218
Database Server on a Shared Disk (Exceptional)	219
Oracle Database Server on a Shared Disk	219
Basic Management Server Configuration	219
Decoupled Management Server Configuration	219
PostgreSQL Database Server on a Shared Disk	221
Basic Management Server Configuration	221
Decoupled Management Server Configuration	221
Database Server on a Remote File System	221
Independent Database Server Configuration	221
Installing and Configuring the HP Operations Management Server on Cluster Nodes	222
Installing and Configuring the HP Operations Management Server on the First Cluster Node	222
Installing and Configuring the HP Operations Management Server on an Additional Cluster Node	225
Log Files	226
 Send Documentation Feedback	 228



# Chapter 1: Installation Requirements for the Management Server

## In This Chapter

This chapter describes how to select the correct management server for HP Operations Manager (HPOM).

Check your system parameters before running the HPOM installation script. This chapter helps you to set the system parameters.

## HPOM Installation and Upgrade Tasks

Before you start to install HPOM, you must decide whether you want to install a new version of HPOM or perform an upgrade from a previous version of HPOM. Depending on what you want to do, choose among the HPOM installation and upgrade tasks listed in [Table 1](#). Keep in mind that you can also install or upgrade HPOM in a cluster environment.

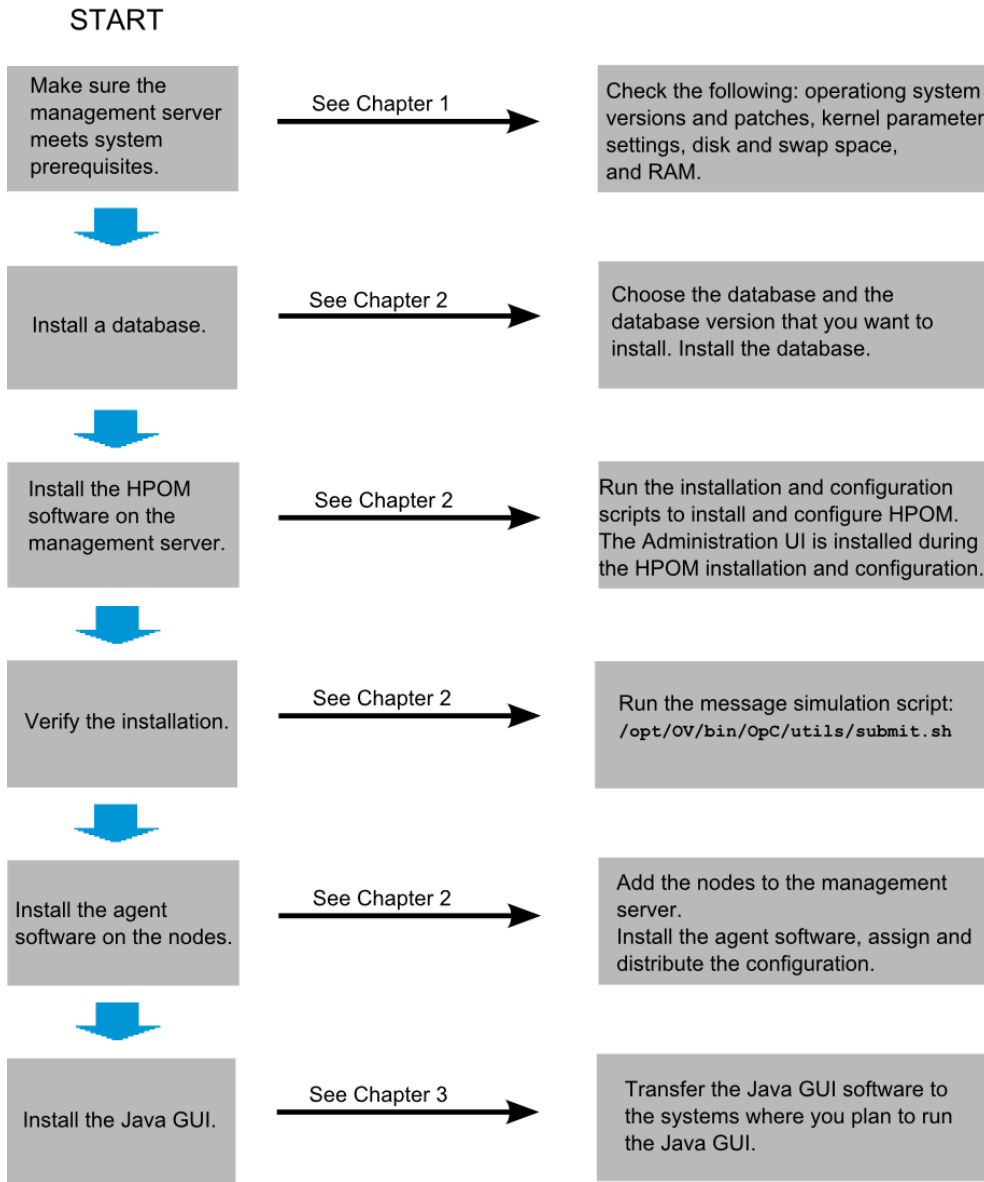
Table 1: HPOM Installation and Upgrade Tasks

Task	Requirement	Reference
1. Install HPOM on the management server.  Keep in mind that the Administration UI is installed during the HPOM installation and configuration.	Minimum hardware and software requirements for the HP Operations management server must be met.	This chapter  <a href="#">"Installing and Configuring HPOM on the Management Server" on page 25</a>
2. Install the Java GUI.	<ul style="list-style-type: none"><li>• HPOM must be installed on the management server.</li><li>• Install the Java GUI software on the systems where the Java GUI will be running.</li></ul>	<a href="#">"Installing the Java GUI" on page 67</a>
3. Install HPOM in a	<ul style="list-style-type: none"><li>• Install HPOM on the first cluster</li></ul>	<a href="#">"Installing HPOM in an HP</a>

HPOM Installation and Upgrade Tasks, continued

Task	Requirement	Reference
cluster environment.	node. <ul style="list-style-type: none"> <li>• Install HPOM on additional cluster nodes.</li> </ul>	<a href="#">ServiceGuard Environment" on page 182</a> <a href="#">"Installing HPOM in a Veritas Cluster Environment" on page 206</a>
5. Upgrade HPOM.	Minimum hardware and software requirements for the HP Operations management server must be met.	This chapter <a href="#">"Upgrading HPOM to Version 9.2x" on page 150</a>
6. Install or update the HP Operations agent on managed nodes.	<ul style="list-style-type: none"> <li>• HPOM must be installed on the management server.</li> <li>• Add the nodes to the HP Operations management server.</li> <li>• Install the HP Operations agent software, and then assign and distribute the configuration.</li> </ul>	<i>HPOM Administrator's Reference</i>

**Figure 1: Summary of Standard HPOM Installation Tasks**



## Verifying Installation Requirements

The HP Operations management server is the controlling element of the entire HPOM system, so you should carefully select the right system to host the management server. Before selecting the system, calculate how many of the following it will have:

- Concurrent operators
- Messages processed
- Monitored nodes

Migrating the management server to a larger system at a later date requires considerable effort, particularly if your configuration is large and includes hundreds or thousands of managed nodes.

Before installing HPOM, see the following topics:

- ["Hardware Requirements" below](#)
- ["Software Requirements" on page 20](#)
- ["Administration UI Requirements" on page 22](#)

Plan your HPOM installation carefully. If you have never used HPOM before, you may want to install and configure it in an isolated test environment before moving it into your production environment. This isolation enables you to gain experience with HPOM and design a configuration that represents a reasonable test of your use of HPOM.

## Hardware Requirements

The system you select as the management server must meet the following hardware requirements:

- HP Integrity servers
- Additional disk space
- Additional RAM
- Swap space (see [Table 3](#))
- DVD-ROM drive (*optional and can be mounted remotely*)

**Note:** It is strongly recommended that you use a multiple-CPU system for the HP Operations management server, with the possibility to add additional CPUs, RAM, and disk space to the system at a later time if needed.

You can install an Oracle database or a PostgreSQL database on a dedicated system. For further information, see ["Setting Up HPOM with a Remote/Manual Oracle Database" on page 86](#) or ["Setting Up HPOM with a Remote/Manual PostgreSQL Database" on page 98](#).

## Required Disk Space

Before selecting a system to host the management server, review the following questions:

1. **How much disk space is available on the system?**

The total recommended disk space for the HP Operations management server is approximately 20 GB. [Table 2](#) shows how much disk space is required for file systems.



Table 2: Disk Space Required for File Systems

File System	Required Disk Space (GB)
/etc/opt/OV	2
/var/opt/OV	5
/opt/OV	3.5

Review the disk requirements of any other applications, such as HP Performance Manager, that you want to install on the management server in the future.

If you do not have enough disk space in the file tree, you can use one of the following methods to solve the problem:

- Mount a dedicated volume for the directory.
- Make the directory a symbolic link to a file system with enough disk space.

**Note:** Do not use NFS-mounted file systems. These systems can adversely affect the performance of HPOM. For more information, see the *HPOM Administrator's Reference*.

For details about the HPOM directory structure, see "[Directory Structure on the Management Server](#)" on page 124.

## 2. How fast is the average disk I/O time?

The disk I/O time affects the application start-up time and the swapping activities. It is recommended that you distribute the database, the HPOM binaries, and the runtime data over several disks. To maintain optimum performance, do not locate swap space on the same disks as the HPOM binaries and the database.

## Required RAM and Swap Space

The amount of available RAM and swap space determines whether applications can run, and also how fast they can run. The more RAM you make available, the better application performance is achieved. The application performance improves because increased RAM reduces the swapping and paging activities of the system.

Before selecting a system to serve as your management server, review the following questions:

### 1. How much memory (RAM) is installed on the system?

The HP Operations management server requires at least 2 GB of dedicated RAM. In addition, you will need approximately 16–20 MB of RAM, plus 6 MB per 1000 active messages for every HPOM Java GUI session, including Service Navigator.

The actual RAM requirements depend heavily on your production environment and mode of use. The factors that affect the RAM requirements include: the number and frequency of HPOM messages, the number of operators working in parallel, and the number of managed nodes. Memory consumption of the Java GUI needed on the server and the display station may be approximately computed.

**2. Does the system provide enough swap space?**

In most cases, you need a total of 4 GB of swap space on the management server system.

**Note:** Use device swap space rather than file system swap space for improved system performance.

Individual requirements are listed in [Table 3](#).

Table 3: Minimum Swap Space Required for HPOM Installation on the Management Server

Product	Required Swap Space (MB)
HP-UX 11i Operating System	1024
Oracle Database	2048 <sup>a</sup>
HP Operations Manager	1024 <sup>b</sup>
<b>Approximate Total</b>	<b>4096</b>

To check your currently available swap space, run the following command:

```
/usr/sbin/swapinfo
```

To achieve the best performance and to avoid a disk access bottleneck, do not locate the database and the swap space on the same physical disk.

**3. How many HPOM users will work at the same time?**

The number of users influences the number of parallel GUIs running on the management server. For each additional operating Java GUI and Service Navigator, about 16-20 MB of RAM or swap space is required, plus 6 MB per 1000 active messages.

If required, adapt the `maxdsiz` kernel parameter.

**4. How many background graphics are integrated into Service Navigator?**

Background graphics can also slow down the system by using excessive amounts of RAM.

<sup>a</sup>The value recommended by Oracle is equal to the system physical memory (RAM) or 2 GB, whichever is greater. For the PostgreSQL database, swap space is not required.

<sup>b</sup>This value depends on the number of GUIs running in parallel, and on the number of active and acknowledged messages. For each additional operating Java GUI and Service Navigator, about 16-20 MB of RAM or swap space is required, plus 6 MB per 1000 active messages.

Reserve enough physical memory to accommodate all the virtual memory needs of HPOM. This extra memory will eliminate the need for process swapping, and will result in the best possible performance. The performance of HPOM can decrease if swapping becomes necessary.

## Performance Requirements

The speed with which HPOM processes messages and the Java GUI performance both depend on the available CPU time as well as the overall CPU power. Therefore, consider the demands of other installed applications on CPU time, disk access, and RAM or swap space usage.

**Note:** It is strongly recommended that you use a multiple-CPU system for the management server system, especially if you plan to run multiple Java GUIs.

Because the throughput of LAN packets can affect the management server performance, you should not use the management server system for other purposes, such as NFS, NIS (YP), DNS, and so on. However, configuring the HP Operations management server system as a secondary Domain Name Server (DNS) can help to increase the speed of name lookups.

## Intersystem Connection Requirements

The connection between the managed nodes and the HP Operations management server affects the time HPOM needs to install the HPOM software, the time it takes to configure the software on the managed nodes, and the time needed to respond to problems.

Before setting up the connection between the managed nodes and the HP Operations management server, review the following questions:

**1. Is the system accessible all the time (at least while HPOM operators are working)?**

The management server should be accessible at least while the managed nodes are operating.

If it is not, the following inconveniences can occur:

- Automatic actions that do not run directly on the local managed node cannot be performed while the management server is down.
- When the management server is restarted, the managed nodes forward all locally buffered HPOM messages to the management server. If hundreds or thousands of messages need to be processed, this has a significant effect on the performance of HPOM.

**2. Is the system located centrally as regards network connectivity and network speed?**

To minimize the HPOM response time, a fast network (LAN) should be available between the management server system and its managed nodes. For example, the management server should not be connected by a serial line or X.25 with all the other systems networked in a LAN.

**3. Are the display stations of the HPOM operators and the management server connected by**

**fast lines?**

Having fast lines between the management server and the operator workstations is strongly recommended.

## Software Requirements

Before you install HPOM, the following software must be correctly installed on the management server.

### Operating System

Table 4 shows on which operating system version the HP Operations management server is supported.

Table 4: Supported Operating System Version for the Management Server

Operating System	Platform	Supported Operating System Version
HP-UX 11i	HP Integrity servers	HP-UX 11i v3

HPOM on HP-UX 11i v3 is a 32-bit application, built to run on HP-UX on HP Integrity systems with a cleaner code and higher performance. HPOM runs on the 64-bit HP-UX 11i v3 operating system, but it does not support integrations with 64-bit applications on the API level. Depending on the type of database you use with HPOM, notice the following:

- The Oracle database server is a 64-bit application and therefore it must be installed on a system running a 64-bit HP-UX 11i v3 operating system. HPOM connects to the Oracle database through the 32-bit SQL interface.
- The PostgreSQL installation on the HP Operations management server must be the 32-bit version installation or must include a 32-bit client library package that contains the `libpq` and `libecpg` libraries.

### Kernel Parameters

Several of the kernel parameters must be increased on the HP Operations management server because the operating system default values are too small. The `ovoinstall` script checks your current settings.

Table 5: Minimum Kernel Settings Required for HPOM Installation on the Management Server

Kernel Parameter	Value
fs_async	0
ksi_alloc_max	(nproc*8)
executable_stack	0
max_thread_proc	1024
maxdsiz	1024
maxdsiz_64bit	0x40000000
maxfiles	0x80000000
maxssiz	256 <sup>a</sup>
maxssiz_64bit	0x80000000
maxuprc	0x40000000
msgmni	0x40000000
msgtql	((nproc*9)/10)
ncsize	(nproc)
nflocks	(nproc)
ninode	(nproc)
nkthread	35840
nproc	(nproc)
semmni	(8*nproc+2048)
semmns	((nproc*7)/4)+ 16)
semmnu	4096
semvmx	(nproc)
shmmax	(semnmi*2)
shmmni	(nproc-4)
shmseg	32767
vps_ceiling	size of memory or 0x40000000 (higher one)
	4096
	512
	64

**Caution:** On the HP Operations management server with a high number of RCP nodes, the ovbbccb process opens many connections and may therefore run out of the available file descriptors. As a result, the agents start buffering.

To avoid this problem, increase the number of file descriptors to 4096 on the management server. Make sure the `maxfiles` kernel parameter is set to 4096.

<sup>a</sup>If your installation includes more than 35 nodes that use HTTPS communication, increase the setting of `maxfiles` to  $3 * \text{Number\_of\_nodes} + 15$ . If your installation includes more than six concurrent users accessing the Java GUI as the same HPOM operator, increase the setting of `maxfiles` to  $14 * \text{Number\_of\_Users} + 28$ .

## Operating System and Environment Patches

The `ovoinstall` script checks the operating system patches that are currently installed on the HP Operations management server.

**Caution:** Before you install any of the required operating system patches, read the README file supplied with the patch.

For latest information about the required patches, see the *HPOM Software Release Notes*. This document is available at the following location:

<https://softwaresupport.hp.com/group/softwaresupport/search-result?keyword=>

At the time of installation, the documented patches may be superseded. Use the latest patches from the following location:

<https://softwaresupport.hp.com/group/softwaresupport/patches>

## Administration UI Requirements

The Administration UI is installed during the installation and configuration of HPOM, so make sure that you also perform all the checks described in this section.

**Caution:** Make sure that you have at least 1.2 GB of free disk space in the `/tmp` directory. Otherwise, the installation of the Administration UI may fail.

## Previous Configuration Value Pack (CVP) Version

An upgrade from CVP to the Administration UI is not supported. Instead, you need to remove the existing CVP software and install the Administration UI after that.

## Passwords

Make sure that you have access to the HPOM database user password.

Any database user with read access to the HPOM database objects can be used. Both `opc_op` and `opc_report` users who are created during the HP Operations management server installation fulfill this requirement.

**Note:** *Oracle only:* Oracle 11g or higher has password aging enabled by default. This means that passwords expire after 6 months. If the password of the Oracle user that HPOM uses to connect to the database expires, HPOM cannot connect to the database. For detailed information, see the

## HPOM Database Settings

Make sure you verify the database parameters of your HP Operations management server by using the `tnsping` and `lsnrctl status` commands for the Oracle database or checking the `ovdbconf` file for the PostgreSQL database.

### Updating the Administration UI When Modifying the Database Path

When the database path is modified, follow these steps:

1. Stop the Administration UI as follows:

```
/opt/OV/OMU/adminUI/adminui stop
```

2. Set the correct path in the `/opt/OV/OMU/adminUI/midas_env.sh` file.

3. Change the URLs appropriately and update the following files with the correct values:

```
/opt/OV/OMU/adminUI/conf/ovoinstall.properties
```

```
/opt/OV/OMU/adminUI/conf/ovoconfig.properties
```

```
/opt/OV/OMU/adminUI/conf/opccfg.properties
```

```
/opt/OV/OMU/adminUI/conf/ovoappl.properties
```

4. Start the Administration UI as follows:

```
/opt/OV/OMU/adminUI/adminui start
```

## Web Browser Support

The Administration UI uses a GUI that can be accessed by any standard web browser from the user's workstation.

The following web browsers are supported:

- Microsoft Internet Explorer 9 or higher

**Caution:** Internet Explorer on CITRIX is not supported.

- Mozilla Firefox 24 or higher
- Chrome 32 or higher
- Safari 6 or higher

For the most up-to-date list of supported web browser versions and architectures, see the support matrix at the following location:

<http://support.openview.hp.com/selfsolve/document/KM323488>

## HPOM Database Configuration

HPOM uses a database instance to store its configuration data and the Administration UI obtains the HPOM data from that database instance.

**Caution:** Make sure to review and verify all connection parameters. The majority of configuration problems appear because of incorrect connection settings (for example, when non-standard ports or incorrect hostnames are used).

The Administration UI attempts to detect database settings by examining the `/etc/opt/OV/share/conf/ovdbconf` file. Keep in mind that some values such as the Oracle listener port are not stored in this file.

*Oracle RAC environments only:* The correct configuration setup must be performed after the Administration UI is installed.

*HA cluster only:* If you use the Oracle database that runs as an HA cluster package, provide the virtual cluster hostname of that HA cluster package.

## Database Passwords

The passwords for the database users are stored in an encrypted form inside the Administration UI configuration files.

If you need to change the passwords after installing the Administration UI, follow these steps:

1. Reconfigure the Administration UI by running the following command:

```
/opt/OV/OMU/adminUI/adminui password -u ovodb -a -p <new_password>
```

2. Restart the Administration UI by running the following commands:

```
/opt/OV/OMU/adminUI/adminui clean
```

```
/opt/OV/OMU/adminUI/adminui start
```

For more information about configuring passwords later, see the *HPOM Administrator's Reference*.

## Supported Agent Versions

For the most up-to-date list of supported HP Operations agent versions, see the support matrix at the following location:

<http://support.openview.hp.com/selfsolve/document/KM323488>



# Chapter 2: Installing and Configuring HPOM on the Management Server

## In This Chapter

This chapter explains how to do the following:

- Install and configure HPOM for the first time on the management server.
- Set up a database for use with HPOM.
- Start HPOM and verify the installation.
- Create additional database users.
- Reconfigure HPOM.

**Note:** The HP Operations agent software is automatically installed during the installation of the HPOM software on the HP Operations management server.

## Before Installing and Configuring HPOM

Before you install and configure HPOM, make sure that your system meets the following prerequisites:

- The HP-UX 11i operating system must be installed.
- Kernel parameters on the management server must be adapted.  
For more information, see ["Verifying Installation Requirements" on page 15](#).
- HP-UX 11i operating system patches must be installed.
- The CDE-English.CDE.Runtime.CDE-DTTERM package must be installed.
- Sufficient disk space must be available in the right partitions of the file system.  
For more information, see ["Required Disk Space" on page 16](#).
- The 0803 bundle for HP-UX 11i v3 on HP Integrity or later must be installed.
- Input and output data for multiple language support must be configured if you use any non-ASCII character.  
For more information, see ["Configuring Input/Output for Multiple Language Support" on the next page](#).

## Configuring Input/Output for Multiple Language Support

If you consider using any non-ASCII character, you must configure Input/Output for multiple language support to allow the use of UTF-8. However, this configuration is recommended even if you use only English characters.

To configure Input/Output for multiple language support, follow these steps:

1. Depending on the language, set locales on the management server:
  - For an English language environment, the following variables can be used:

```
export LANG=C.utf8
export LC_ALL=C.utf8
```

- For other languages, make sure that you do the following:

- Choose a locale that uses the utf8 character set.

For example:

```
en_US.utf8
es_ES.utf8
ja_JP.utf8
sl_SI.utf8
```

- Ensure that this locale setting is applied system-wide. To do this, you can set the LANG and LC\_ALL variables in the root user's `.profile` file, edit the system environment files (for example, `/etc/rc.config.d/LANG`), or use the `geocustoms` command.

**Note:** The LANG variable determines the language of HPOM messages, templates, and uploaded configuration. If some of the contents are not available for the chosen locale, HPOM defaults to the English contents instead.

2. Set locales on the client system:

- Windows XP:

Navigate to the Regional and Language Options in the Control Panel.

Click the **Advanced** tab, and then select the **65001 (UTF-8)** check box in Code page conversion tables.

**Note:** For a detailed procedure, see the Microsoft documentation.

- UNIX:

Make sure that you set locales to a UTF-8 version in the same way as for the management server. To find the appropriate UTF-8 suffix, use `locale -a`.

3. Set up the console or the terminal program to accept UTF-8.

Use only fonts that conform to the Unicode standard (for example, Lucida Console).

## Installing and Configuring HPOM

Before installing and configuring HPOM, make sure that your system meets all the prerequisites detailed in ["Installation Requirements for the Management Server" on page 13](#).

To install and configure HPOM, complete these tasks:

- Task 1: ["Installing an Oracle Database" below](#) or ["Installing a PostgreSQL Database" on page 41](#)

**Caution:** Before installing a database, you should consider which database you want to use with HPOM, namely an Oracle database or a PostgreSQL database.

- Task 2: ["Installing and Configuring the HPOM Software on the Management Server System" on page 43](#)

**Caution:** Keep in mind the following changes introduced with HPOM 9.20:

- HP Operations agent software is no longer shipped together with HPOM. To obtain the supported agent version, request the agent media 11.1x from HP.
- Standalone installation of the Administration UI is no longer supported. The Administration UI is installed and configured during the installation and configuration of HPOM. Attempting to install the Administration UI by using `install.bin` will result either in the failure of the Administration UI installation or the Administration UI being corrupted.

- Task 3: ["Starting HPOM and Verifying the Installation" on page 59](#)

## Installing an Oracle Database

To use an Oracle database with HPOM, install one of the following:

- Oracle Database 11g Release 1 Enterprise Edition, Standard Edition, or Standard Edition One (with the 11.1.0.7 patch set)
- Oracle Database 11g Release 2 Enterprise Edition, Standard Edition, or Standard Edition One (versions 11.2.0.1–11.2.0.4)

- Oracle Database 12c Release 1 Enterprise Edition, Standard Edition, or Standard Edition One (12.1.0.1 or 12.1.0.2)

For the latest Oracle system requirements (for example, system patches), more detailed instructions than those provided in this section, or non-standard installations, see the documentation supplied with the Oracle Database product.

For information about the support of later versions of Oracle, see the latest edition of the *HPOM Software Release Notes*.

**Note:** Oracle 11g and Oracle 12c are the Oracle Corporation products and cannot be purchased directly from Hewlett-Packard.

This section describes the following:

- ["Required Oracle Products" below](#)
- ["Using an Existing Oracle Database" below](#)
- ["Before Installing an Oracle Database" on the next page](#)
- ["Preparation Steps" on page 31](#)
- ["Installing Oracle Database 11g Release 1" on page 32](#)
- ["Installing Oracle Database 11g Release 2" on page 33](#)
- ["Installing Oracle Database 12c" on page 37](#)

## Required Oracle Products

A stand-alone HPOM system has the database and all management server processes, including user interface processes, running on the same system. However, if the database is installed on a different server than the HP Operations management server, you must additionally install the Oracle products on the management server as described in ["Setting Up HPOM with a Remote/Manual Oracle Database" on page 86](#). These products enable remote access to the Oracle database.

## Using an Existing Oracle Database

HPOM can be installed and configured by using an existing database, but it requires its own database instance.

If you have the existing Oracle database and want to verify which Oracle products are installed, use the Oracle Universal Installer to view the installed Oracle products:

1. Switch to the `oracle` user:  
`su - oracle`

2. Run the Oracle Universal Installer:

```
$ORACLE_HOME/oui/bin/runInstaller
```

3. In the Oracle Universal Installer Welcome window, click **Installed Products...** to view the installed Oracle products.

If you want to use the existing Oracle database, do the following:

1. See the Oracle product documentation to make sure that the database is compatible with Oracle database version 11g (11.1 or 11.2) or 12c (12.1).
2. Make sure Oracle environment variables are set as described in ["Before Installing an Oracle Database" below](#).
3. Continue with ["Installing and Configuring the HPOM Software on the Management Server System" on page 43](#).

## Before Installing an Oracle Database

Before you install an Oracle database on the management server, follow these steps:

1. Make sure that your system meets the hardware and software requirements listed in ["Installation Requirements for the Management Server" on page 13](#).

**Note:** Dynamically linked Oracle environments are not supported.

2. Run SMH as the root user, and then create the `oracle` user with the following attributes:
  - a. Create UNIX groups named `oinstall`, `dba`, and `oper` (the ID of each group should be greater than 100).
  - b. Create a UNIX user named `oracle` (the user ID should be greater than 100).

**Caution:** In a cluster environment, you must use the same IDs on all cluster nodes. Otherwise, the startup of the HA resource group on the second node fails.

- c. Make the `oracle` user a member of `oinstall` as the primary group and `dba` and `oper` as the secondary groups.
  - d. As the home directory of the `oracle` user, use the following:

```
/home/oracle
```
  - e. Make sure that a POSIX shell (for example, `sh`) is assigned as the default shell for the `oracle` user.
3. As the root user, set `umask` to allow users to access Oracle binaries by running the following command:

```
umask 022
```

4. Create the directories required by the Oracle installation, and then change the ownership and set correct permissions as follows:

- a. Create the ORACLE\_HOME directory by running the following command:

```
mkdir -p /opt/oracle/product/<version>
```

In this instance, *<version>* is the Oracle database version, 11.1.0, 11.2.0, or 12.1.0.

**Note:** */opt/oracle/product/<version>* is the value recommended by HPOM. This value meets the Optimal Flexible Architecture (OFA) directory structure recommended by Oracle.

You can also choose a different directory, but you must use it consistently in all subsequent steps.

- b. Create a base directory for the Oracle installation files by running the following command:

```
mkdir -p /opt/oracle/oraInventory
```

**Note:** You can also choose a different directory, but you must use it consistently in all subsequent steps.

- c. Change the ownership and set correct permissions by running the following commands:

```
chown -R oracle:oinstall /opt/oracle/oraInventory  
chmod -R 770 /opt/oracle/oraInventory
```

5. Change the ownership of the directories to oracle:oinstall by typing the following command:

```
chown -R oracle:oinstall /opt/oracle \  
/opt/oracle/product /opt/oracle/product/<version>
```

In this instance, *<version>* is the Oracle database version, 11.1.0, 11.2.0, or 12.1.0.

6. Set the following Oracle environment variables in */home/oracle/.profile* of the oracle user:

- ORACLE\_BASE=/opt/oracle  
export ORACLE\_BASE

This variable determines the location of the Oracle installation. The default recommended setting is */opt/oracle*, but you can use a different installation prefix if needed.

- ORACLE\_HOME=\$ORACLE\_BASE/product/<version>  
export ORACLE\_HOME

In this instance, *<version>* is the Oracle database version, 11.1.0, 11.2.0, or 12.1.0.

This variable determines the location and the version of the Oracle installation. This is the recommended setting, but you can use a different setting if needed.

**Note:** The ORACLE\_BASE and ORACLE\_HOME Oracle environment variables are not mandatory for the operation with HPOM.

- `ORACLE_SID=openview`  
`export ORACLE_SID`

This variable defines the name of the database you will create. The default setting is `openview`, but you can use a different setting if needed.

When using an existing database, use the name of this database for setting `ORACLE_SID`.

When configuring the database, the `ovoconfigure` script detects that a database of this name exists and asks whether you want to use it for the HPOM database objects. If you choose this approach, the HPOM database objects are created within the existing database.

- `ORACLE_TERM=<terminal_type>`  
`export ORACLE_TERM`

This variable defines the type of terminal (for example, `xterm`, `hp`, `ansi`) to be used with the Oracle installer and other Oracle tools.

Make sure to set this variable to the type of your terminal.

- `PATH=$PATH:$ORACLE_HOME/bin`  
`export PATH`

This variable sets the directories through which the system searches to find and execute commands.

7. *If you want to use port 1521 for Oracle listener communication:* Make sure that the `ncube` port is commented out in `/etc/services` (if this file exists on your system):

```
#ncube-lm 1521/tcp # nCube License Manager  
#ncube-lm 1521/udp # nCube License Manager
```

## Preparation Steps

**Note:** Oracle Database 11g Release 1 and Release 2 as well as Oracle Database 12c Release 1 for HP-UX on HP Integrity are available on DVD-ROMs. These products, as well as all required patch sets, can be downloaded from the Oracle web site.

To prepare for an Oracle database installation, follow these steps:

1. Open two terminal windows, and then log on as the `root` user in the first terminal window and as the `oracle` user in the second one.
2. As the `oracle` user, make sure that the `ORACLE_TERM` environment variable is set correctly.

To check the setting, type the following:

```
echo $ORACLE_TERM
```

3. Verify, and if necessary, set the `ORACLE_HOME` and `ORACLE_SID` variables.

4. Set the DISPLAY environment variable by typing the following:

```
DISPLAY=<nodename>:0.0
```

```
export DISPLAY
```

In this instance, *<nodename>* is the name of your system.

5. On most systems, the disk is mounted automatically when you insert it into the disk drive. However, if the disk is not mounted automatically, create a mount point, and then, as the root user, run the following command to mount it:

```
/usr/sbin/mount -F cdfs -o rr /dev/dsk/<cxydz> <mount_point>
```

In this instance, *<mount\_point>* is the disk mount point directory and *<cxydz>* is the device name for the disk (for example, *c0t2d0*).

**Note:** Before proceeding with the installation of the Oracle database, it is recommended that you copy the contents of installation media to a hard disk.

## Installing Oracle Database 11g Release 1

To install Oracle Database 11g Release 1 from the DVD-ROM, follow these steps:

1. As the `oracle` user, start the Oracle Universal Installer by running the following command:

```
<path>/runInstaller
```

In this instance, *<path>* is the full path of the database directory on the installation media.

The Select Installation Method window opens.

2. In the Select Installation Method window, click **Advanced Installation**, and then **Next**.

The Specify Inventory directory and credentials window opens.

**Note:** If an error message appears indicating that the inventory location could not be created, you can safely ignore it.

3. Make sure that the `/opt/oracle/oraInventory` path is given in the Specify Inventory directory and credentials window, and then click **Next**.

The Select Installation Type window appears.

4. In the Select Installation Type window, click either **Enterprise Edition** or **Standard Edition** (according to your needs or your Oracle license agreement), and then click **Next**.

The Install Location window opens.

**Note:** If you plan to run an HP Operations management server in a language other than English, which is the default language, you can add languages by clicking the **Product Languages...** button and selecting languages from the list.



5. In the Install Location window, check that the Oracle variables are set correctly, and then click **Next**.

The Product-Specific Prerequisite Checks window appears.

6. In the Product-Specific Prerequisite Checks window, the result of checking requirements appears. If no problems are reported, click **Next**.

The Select Configuration Option window opens.

**Note:** If a problem report message appears, check all requirements and set them accordingly.

7. In the Select Configuration Option window, click **Install Software Only**, and then **Next**.

The Privileged Operating System Groups window appears.

8. In the Privileged Operating System Groups window, click **Next**.

The Summary window opens.

9. Review the information displayed in the Summary window, and then click **Install** to start the installation.

10. When the Execute Configuration scripts window appears, follow these steps:

- a. Open a terminal window, and then log on as the root user.

- b. Run the following two scripts:

```
${ORACLE_HOME}/root.sh  
/opt/oracle/oraInventory/orainstRoot.sh
```

- c. Return to the Execute Configuration scripts window, and then click **OK** to continue.

The End of Installation window opens.

11. In the End of Installation window, you can verify installed Oracle products.

Click **Exit** when you finish the verification.

12. Install the 11.1.0.7 patch set.

For detailed information about installing the patch set for the Oracle database server, see the Oracle product documentation.

## Installing Oracle Database 11g Release 2

**Note:** Starting with the release of the 11.2.0.2 patch set for Oracle Database 11g Release 2, Oracle database patch sets are full installations of the Oracle Database software. Note the following changes with the new patch set packaging:

- Direct upgrades from previous releases to the most recent patch set are supported.
- Out-of-place patch set upgrades, in which you install the patch set into a new and separate

Oracle home, are the best practice recommendation. In-place upgrades are supported but are not recommended.

- New installations consist of installing the most recent patch set, rather than installing a base release and then upgrading to a patch release.

To install Oracle Database 11g Release 2 from the DVD-ROM, follow these steps:

1. As the `oracle` user, start the Oracle Universal Installer by running the following command:

```
<path>/runInstaller
```

In this instance, `<path>` is the full path of the database directory on the installation media.

Depending on the version of the Oracle database you are installing, one of the following two windows opens:

- *11.2.0.1*: Select Installation Option window
  - *11.2.0.2–11.2.0.4*: Configure Security Updates window
2. *Oracle database version 11.2.0.2–11.2.0.4*: Use the Software Updates feature to dynamically download and apply latest updates.

To dynamically download and apply latest updates, in the Configure Security Updates window, do one of the following:

- If you want to receive information about security issues, follow these steps:
  - i. Either type your email address or select the **I wish to receive security updates via My Oracle Support** check box and type your Oracle support password. Click **Next**.

The Download Software Updates window opens.

- ii. In the Download Software Updates window, do one of the following:

- Apply updates to the downloaded Oracle software, and then click **Next**.
- Skip applying updates to the downloaded Oracle software by clicking **Skip software updates** followed by **Next**.

In both cases, the Select Installation Option window opens.

- If you do not want to receive information about security issues, follow these steps:
  - i. Clear the **I wish to receive security updates via My Oracle Support** check box, and then click **Next**.

You are asked whether you are sure you do not want to receive information about security issues.

- ii. Click **Yes**.

The Download Software Updates window opens.

- iii. In the Download Software Updates window, skip applying updates to the downloaded Oracle software by clicking **Skip software updates** followed by **Next**.

The Select Installation Option window opens.

3. In the Select Installation Option window, click the **Install database software only** radio button, and then click **Next**.

The Grid Installation Options window opens.

4. In the Grid Installation Options window, click **Single instance database installation**, and then click **Next**.

The Select Product Languages window opens.

5. In the Select Product Languages window, you can find a list of available languages that you can select according to your preferences (for example, if you plan to run an HP Operations management server in a language other than English, which is the default language, or if you want to receive Oracle messages in a different language).

After you select the languages you want, click **Next**.

The Select Database Edition window opens.

6. In the Select Database Edition window, click **Enterprise Edition** or **Standard Edition** (according to your needs or your Oracle license agreement), and then click **Next**.

The Specify Installation Location window opens.

7. In the Specify Installation Location window, check that the Oracle base and software location values correspond to the ORACLE\_BASE and ORACLE\_HOME values you created, and then click **Next**.

The Privileged Operating System Groups window opens.

8. In the Privileged Operating System Groups window, specify the group names for the Database Administrator group (OSDBA), for example, dba, and optionally, the Database Operator group (OSOPER), for example, oper. Click **Next**.

The Perform Prerequisite Checks window opens.

9. In the Perform Prerequisite Checks window, the result of checking requirements appears. If no problems are reported, click **Next**.

The Summary window opens.

**Note:** If a problem report message appears, check all requirements and set them accordingly.

10. Review the information displayed in the Summary window, and then click **Install** to start the installation.

The Install Product window opens.

11. When the Execute Configuration scripts window appears, follow these steps:

- a. Open a terminal window, and then log on as the root user.
- b. You are requested to run one or both of the following scripts:  

```
 ${ORACLE_HOME}/root.sh  
 /opt/oracle/oraInventory/orainstRoot.sh
```
- c. Return to the Execute Configuration scripts window, and then click **OK** to continue.  
The Finish window opens.

12. In the Finish window, click **Close** to finish the Oracle database installation.

**Caution:** Oracle no longer provides the 32-bit `libclntsh.so` and `libnnz11.so` client libraries together with the 64-bit versions of the Oracle Database server or client. Because HPOM on HP-UX 11i v3 is built as a 32-bit application, you must obtain these libraries for Oracle to work properly.

### Obtaining the `libclntsh.so` and `libnnz11.so` Libraries for Oracle Database 11g Release 2

After you finish the Oracle Database 11g Release 2 installation, obtain the `libclntsh.so` and `libnnz11.so` libraries. To do so, follow these steps:

1. Download the Oracle 11g Release 2 32-bit database client from the Oracle download page, and then uncompress it.

**Note:** It is highly recommended that you use the same version of the Oracle client and the Oracle server.

2. As the root user, set `umask` to allow users to access the Oracle binaries by running the following command:

```
umask 022
```

3. Create the `lib32` subdirectory in the `ORACLE_HOME` directory by running the following command:

```
mkdir -p /opt/oracle/product/11.2.0/lib32
```

4. Assign permissions to the `lib32` subdirectory by running the following commands:

```
chown oracle:oinstall /opt/oracle/product/11.2.0/lib32
```

```
chmod 755 /opt/oracle/product/11.2.0/lib32
```

5. Create a new Oracle home directory by running the following command:

```
mkdir -p <new_oracle_home_directory>
```

For example:

```
mkdir -p /opt/oracle/product/11.2.0-32
```

6. Assign permissions to the new Oracle home directory.

For example, run the following commands:

```
chown oracle:oinstall /opt/oracle/product/11.2.0-32
```

```
chmod 755 /opt/oracle/product/11.2.0-32
```

7. As the `oracle` user, export `ORACLE_HOME=<new_oracle_home>`, and then run the Oracle Universal Installer.

During the Oracle client installation, in the Select Installation Type window, select **Instant Client**.

8. When the installation is finished, copy `libc1ntsh.so.11.1` and `libnnz11.so` from the newly created `ORACLE_HOME` directory to the `lib32` subdirectory in the old `ORACLE_HOME` directory.

Run the following commands:

```
cp /opt/oracle/product/11.2.0-32/libc1ntsh.so.11.1 \
/opt/oracle/product/11.2.0/lib32/
```

```
cp /opt/oracle/product/11.2.0-32/libnnz11.so \
/opt/oracle/product/11.2.0/lib32/
```

9. Navigate to the `lib32` subdirectory of the old `ORACLE_HOME` directory by running the following command:

```
cd /opt/oracle/product/11.2.0/lib32/
```

10. In the `lib32` subdirectory of the old `ORACLE_HOME` directory, create the following link:

```
ln -s libc1ntsh.so.11.1 libc1ntsh.so
```

The new file structure of the old `ORACLE_HOME/lib32` directory must be the following:

```
lrwxr-xr-x libc1ntsh.so -> libc1ntsh.so.11.1
```

```
-rwxr-xr-x libc1ntsh.so.11.1
```

```
-rwxr-xr-x libnnz11.so
```

## Installing Oracle Database 12c

To install Oracle Database 12c from the DVD-ROM, follow these steps:

1. As the `oracle` user, start the Oracle Universal Installer by running the following command:

```
<path>/runInstaller
```

In this instance, `<path>` is the full path of the database directory on the installation media.

The Configure Security Updates window opens.

2. Use the Software Updates feature to dynamically download and apply latest updates.

To dynamically download and apply latest updates, in the Configure Security Updates window, do one of the following:

- If you want to receive information about security issues, follow these steps:
  - i. Either type your email address or select the **I wish to receive security updates via My Oracle Support** check box and type your Oracle support password. Click **Next**.

The Download Software Updates window opens.

- ii. In the Download Software Updates window, do one of the following:
  - Apply updates to the downloaded Oracle software, and then click **Next**.
  - Skip applying updates to the downloaded Oracle software by clicking **Skip software updates** followed by **Next**.

In both cases, the Select Installation Option window opens.

- If you do not want to receive information about security issues, follow these steps:
  - i. Clear the **I wish to receive security updates via My Oracle Support** check box, and then click **Next**.

You are asked whether you are sure you do not want to receive information about security issues.

- ii. Click **Yes**.

The Download Software Updates window opens.

- iii. In the Download Software Updates window, skip applying updates to the downloaded Oracle software by clicking **Skip software updates** followed by **Next**.

The Select Installation Option window opens.

3. In the Select Installation Option window, click the **Install database software only** radio button, and then click **Next**.

The Grid Installation Options window opens.

4. In the Grid Installation Options window, click **Single instance database installation**, and then click **Next**.

The Select Product Languages window opens.

5. In the Select Product Languages window, you can find a list of available languages that you can select according to your preferences (for example, if you plan to run an HP Operations management server in a language other than English, which is the default language, or if you want to receive Oracle messages in a different language).

After you select the languages you want, click **Next**.

The Select Database Edition window opens.

6. In the Select Database Edition window, click **Enterprise Edition** or **Standard Edition** (according to your needs or your Oracle license agreement), and then click **Next**.

The Specify Installation Location window opens.

**Note:** If you install the Oracle database on the system for the first time, the Create Inventory window appears before the Specify Installation Location window. In the Create Inventory window, specify the path to the Oracle inventory directory.

You may get a message warning you that the central inventory is located inside the ORACLE\_BASE directory. In this case, continue by clicking **Yes**.

7. In the Specify Installation Location window, check that the Oracle base and software location values correspond to the ORACLE\_BASE and ORACLE\_HOME values you created, and then click **Next**. The Privileged Operating System groups window opens.

8. In the Privileged Operating System Groups window, specify the group names for the Database Administrator group (OSDBA), for example, dba, and optionally, the Database Operator group (OSOPER), for example, oper. Click **Next**.

The Perform Prerequisite Checks window opens.

9. In the Perform Prerequisite Checks window, the result of checking requirements appears. If no problems are reported, click **Next**.

The Summary window opens.

**Note:** If a problem report message appears, check all requirements and set them accordingly.

10. Review the information displayed in the Summary window, and then click **Install** to start the installation.

The Install Product window opens.

11. When the Execute Configuration scripts window appears, follow these steps:

- a. Open a terminal window, and then log on as the root user.
- b. You are requested to run one or both of the following scripts:

```
${ORACLE_HOME}/root.sh  
/opt/oracle/oraInventory/orainstRoot.sh
```

- c. Return to the Execute Configuration scripts window, and then click **OK** to continue.

The Finish window opens.

12. In the Finish window, click **Close** to finish the Oracle database installation.

**Caution:** Starting with Oracle 12c, the 32-bit version of the Oracle database server is no longer available. However, because HPOM on HP-UX 11i v3 is built as a 32-bit application, you must obtain the 32-bit versions of the Oracle client libraries (that is, libclntsh.so and libnnz12.so) for HPOM to work properly. To obtain them, go to the Oracle download page.

### Obtaining the libclntsh.so and libnnz12.so Libraries for Oracle Database 12c

After you finish the Oracle Database 12c installation, install Oracle 32-bit client libraries that are required by HPOM. To do so, follow these steps:

1. Create the `lib32` subdirectory in the `ORACLE_HOME` directory by running the following command:

```
mkdir -p /opt/oracle/product/12.1.0/lib32
```

2. Assign permissions to the `lib32` subdirectory by running the following commands:

```
chown oracle:oinstall /opt/oracle/product/12.1.0/lib32
```

```
chmod 755 /opt/oracle/product/12.1.0/lib32
```

3. Install the 32-bit version of Oracle Instant Client 12c, and then copy all of its files to `/opt/oracle/product/12.1.0/lib32/`.

4. Create the following soft links to avoid possible compatibility issues:

```
ln -s /opt/oracle/product/12.1.0/lib32/libnnz12.so \
/opt/oracle/product/12.1.0/lib32/libnnz11.so
```

```
ln -s /opt/oracle/product/12.1.0/lib32/libclntsh.so.12.1 \
/opt/oracle/product/12.1.0/lib32/libclntsh.so.11.1
```

```
ln -s libclntsh.so.12.1 libclntsh.so
```

5. Set the `LD_LIBRARY_PATH` environment variable to `/opt/oracle/product/12.1.0/lib32` globally. For example, set this variable in the root user's `.profile` file and also, if non-root operation is used, in the `.profile` file of each non-root user in HPOM.

6. If you plan to switch HPOM to non-root operation, do the following:

- a. Obtain the embedded path of the `libclntsh.so.12.1` library:

```
catr ${ORACLE_HOME}/lib32/libclntsh.so.12.1 | grep "embedded path"
```

An output similar to the following one appears:

```
embedded path  enabled first /ade/b/2450/oracle/lib
```

- b. Recreate the directory structure for the obtained path on the HP Operations management server, excluding the `lib` part. For example:

```
mkdir -p /ade/b/2450/oracle/
```

- c. Create a symbolic link from the embedded path to `${ORACLE_HOME}/lib32`. For example, run the following command:

```
ln -s ${ORACLE_HOME}/lib32 /ade/b/2450/oracle/lib
```

**Caution:** After installing and configuring HPOM, make sure to set the `OPCUIWWW_LIB_PATH` variable as follows:

```
/opt/OV/bin/ovconfchg -ovrg server -ns opc.opcuiwww \
-set OPCUIWWW_LIB_PATH /opt/oracle/product/12.1.0/lib32
```



# Installing a PostgreSQL Database

To use a PostgreSQL database with HPOM, install PostgreSQL version 9.1, 9.2, 9.3, or 9.4.

For detailed information about installing a PostgreSQL database, see "[Installing a PostgreSQL Database](#)" below. For the latest PostgreSQL system requirements or more detailed instructions than those provided in this section, see the PostgreSQL documentation that is available at the following location:

<http://www.postgresql.org/docs>

## Required PostgreSQL Products

A stand-alone HPOM system has the database and all management server processes, including user interface processes, running on the same system. However, if the database is installed on a different server than the HP Operations management server, you must additionally install the PostgreSQL client on the management server as described in "[Setting Up HPOM with a Remote/Manual PostgreSQL Database](#)" on page 98. This client enables remote access to the PostgreSQL database.

**Caution:** The set of PostgreSQL server binaries you choose (for example, Open Source, EnterpriseDB, or compiled from source) must contain the server binaries that are built with enabled thread safety. You must also make sure that the PostgreSQL installation on the HP Operations management server is the 32-bit version installation, or that it includes a 32-bit client library package with the `libpq` and `libecpg` libraries.

## Before Installing a PostgreSQL Database

Make sure that your system meets the hardware and software requirements listed in "[Installation Requirements for the Management Server](#)" on page 13.

## Installing a PostgreSQL Database

This section describes how to install a PostgreSQL database.

**Note:** The PostgreSQL object-relational database management system can be downloaded from the PostgreSQL web site.

After you choose the PostgreSQL database version that you want to install, complete the following tasks:

- Task 1: "[Installing PostgreSQL Server Binaries](#)" below
- Task 2: "[Preparing HPOM to Use the PostgreSQL Database](#)" below
- Task 3: "[Creating and Configuring a Database Cluster](#)" on the next page

## Installing PostgreSQL Server Binaries

To obtain and install server binaries for the PostgreSQL database, you can use your operating system package manager, compile the PostgreSQL server binaries from source, or download the PostgreSQL server binaries from one of the following locations:

- <http://hpux.connect.org.uk>

On the Porting and Archive Centre for HP-UX web site, type `postgres` in the Search Term box, and then choose the version of the package you want to download.

- <http://www.postgresql.org/download><sup>a</sup>
- <http://enterprisedb.com/downloads/postgres-postgresql-downloads><sup>b</sup>

When installing the PostgreSQL server binaries, keep in mind the following:

- The installation package may have dependencies. You can find the links to these dependencies on the same page as the PostgreSQL binary package. For details, see the corresponding package documentation.
- For the HP Operations management server, a 32-bit version of PostgreSQL or the one that includes a 32-bit client library package that contains the `libpq` and `libecpg` libraries is required.
- When building from source, thread safety must be enabled. Follow the instructions provided for each package. Depending on the package you choose, one or more sub-packages for the server, the client, or the libraries are available. In a local scenario, all of them are needed for the HP Operations management server. In a remote scenario, you must install the packages for the server, the client, and the libraries on the PostgreSQL server, while the packages for the client and the libraries must be installed on the HP Operations management server.
- Add the directory where the PostgreSQL binaries are stored into `PATH`. Otherwise, the operating system may include a different and usually older version of PostgreSQL, which may create conflicts.

## Preparing HPOM to Use the PostgreSQL Database

PostgreSQL requires an operating system user (usually named `postgres`) that controls database processes and has access to all PostgreSQL binaries and HPOM database directories. This user

<sup>a</sup>Source code is also available for download from this location.

<sup>b</sup>PostgreSQL Plus Advanced Server requires a license.

belongs to an operating system user group (usually named `postgres`). If the user is not created or you want to use another user, create it by using the operating system tools.

**Caution:** In a cluster environment, you must use the same user and group IDs on all cluster nodes. Otherwise, the startup of the HA resource group on the second node fails.

## Creating and Configuring a Database Cluster

In PostgreSQL, a database cluster is a server instance that controls a group of databases. To create and configure a database cluster, choose one of the following three methods:

- *Automatically:*

During `ovoconfigure`. In this case, a database cluster is created locally on the HP Operations management server.

For details, see ["Configuring a PostgreSQL Database" on page 55](#).

- *Semi-automatically:*

By running the `psqlcluster` tool on the database server system. In this case, a local or remote database cluster is created.

For details, see ["Creating and Configuring a PostgreSQL Database Cluster by Using the psqlcluster Tool" on page 100](#).

- *Manually:*

This method enables additional customization of cluster parameters and a file location.

For details, see ["Creating and Configuring a PostgreSQL Database Cluster Manually" on page 101](#).

## Installing and Configuring the HPOM Software on the Management Server System

This section describes how to install and configure the HPOM software on the management server by using the HPOM installation and configuration scripts, `ovoinstall` and `ovoconfigure`.

To ensure that the HPOM installation runs smoothly, your system must meet all the prerequisites detailed in ["Installation Requirements for the Management Server" on page 13](#).

Before running the `ovoinstall` script, decide whether you want to set the database to start automatically every time you restart your system.

## Usage of the ovoidinstall and ovoconfigure Scripts

This section contains the description of the ovoidinstall and ovoconfigure scripts as well as options that can be used with these scripts. For detailed information about installation and configuration steps, see ["Installing and Configuring the HPOM Software on the Management Server" on page 46](#).

After you install the HPOM software on the management server, the ovoidinstall script asks you if you want to continue with the server software configuration. If you answer in the affirmative, the ovoconfigure script is started automatically.

**Caution:** Do not install HPOM product bundles directly by using HP Software Distributor (SD-UX). Use ovoidinstall for the administration of the HPOM software on the HP Operations management server.

In addition, it is not possible to install HPOM from the software depot server.

The syntax of the ovoidinstall and ovoconfigure scripts is the same and is as follows:

```
ovoidinstall|ovoconfigure  
  [-pkgdir <package_dir>] [-agtdir <software_dir>]  
  [-adminUIdir <software_dir>]  
  [-defaults <defaults_file>]  
  [-no_clear_display] [-u|-unattended] [-check]
```

You can use the following options with the ovoidinstall and ovoconfigure scripts:

-pkgdir <package_dir>	Enables you to specify the location of HPOM packages.
-agtdir <software_dir>	Enables you to specify the HP Operations agent software location.
-adminUIdir <software_dir>	Enables you to specify the Administration UI software location.
-defaults <defaults_file>	Enables you to specify the file containing the default answers to the ovoconfigure questions.
-no_clear_display	By specifying this option, you can stop the ovoconfigure script from cleaning the screen contents after each successfully finished step.
-u -unattended	By specifying this option, no questions are asked during the HPOM software installation and configuration procedures. Configuration values are taken from the defaults file.
-check	Enables you to check prerequisites without the need to install

	HPOM packages. The <code>ovoconfigure</code> script enables you to check kernel parameters, RAM and swap space, free disk space, operating system patches, installed software, running processes, and required files respectively.
<code>-h -? -help</code>	Shows the usage of the script.

## Before Running `ovoinstall`

Before running the `ovoinstall` script, observe the following considerations:

- Verify whether you use Network Information Services (NIS) for user or group management. This information is available from the entries for `passwd` and the group in the `/etc/nsswitch.conf` file.

If you use NIS, keep the following in mind before running the `ovoinstall` script:

- If the `opc_op` user already exists in the NIS environment, it must belong to the `opcgrp` group. If it does not exist, the `opc_op` user will be created by the `ovoinstall` script.
- Home directories of the `opc_op` and `oracle` or `postgres` users must be accessible on the HP Operations management server as well as the same as on the NIS server.
- If you plan to use PostgreSQL as the database server, both the PostgreSQL OS `DBA` user and its group must be created.

If you do not use NIS for user or group management, `ovoinstall` automatically sets up both groups and users.

- If you do not want your user account and group configuration to be modified during the installation and configuration of the HPOM software on the management server, make sure to configure the `opc_op` user and the `opcgrp` group before starting the installation.

## Preparing for the HPOM Software Installation and Configuration from a DVD-ROM

To prepare for the HPOM software installation and configuration from a DVD-ROM, insert the HPOM server installation DVD into the DVD-ROM drive.

On most systems, the disk is mounted automatically. However, if the disk is not mounted automatically, follow these steps to mount it:

1. Create a directory to mount the DVD-ROM by running the following command:

```
mkdir /<mount_point>
```

For example:

```
mkdir /dvdrom
```

2. Mount the DVD-ROM by running the following command:

```
/usr/sbin/mount -F cdfs -o rr /dev/dsk/<cxydz> <mount_point>
```

In this instance, *<mount\_point>* is the disk mount point directory and *<cxydz>* is the device name for the disk (for example, *c0t2d0*).

You can also run SMH and mount the DVD-ROM to a specific path in the Disks and File Systems window.

Before proceeding with the installation and configuration of HPOM on the management server, it is recommended that you copy the contents of installation media to a hard disk, and then run the installation process directly from there.

## Installing and Configuring the HPOM Software on the Management Server

Installing and configuring the HPOM software on the management server is a simple and fast procedure, partly owing to the list of possible options offered after each installation or configuration step (see [Table 6](#)).

Table 6: Installation and Configuration Procedure Options

Options	Description
back <sup>a</sup>	Enables you to return to the previous step.
exit	Enables you to stop the procedure.
y n <sup>b</sup>	Offers a possibility to answer in the affirmative or in the negative.
“default value”	Enables you to accept the default value.
?	Enables you to gain more information.

**Note:** If at any point either `ovoinstall` or `ovoconfigure` returns a value with an error, type `back` and repeat the step, type `exit` and cancel the procedure, or type `?` and gain more information.

To install and configure the HPOM software on the management server, follow these steps:

<sup>a</sup>To correct any value, type `back`, and then set the value to match the required value.

<sup>b</sup>This option is not available with all procedure steps.

1. Log on as the root user.
2. Make sure that the LANG environment variable is set to a UTF-8 locale.

For more information about setting the environment variable, see "[Configuring Input/Output for Multiple Language Support](#)" on page 26.

3. Start the HPOM installation:

- If you install HPOM from a DVD-ROM, type the following:

```
<mount_point>/ovoinstall
```

In this instance, *<mount\_point>* is the location where the HPOM installation DVD is mounted.

- If you install HPOM using DVD content, type the following:

```
<master_directory>/HPOMDVD/ovoinstall
```

For example, if you created the `/tmp` directory as the master directory, you can start `ovoinstall` by typing the following:

```
/tmp/HPOMDVD/ovoinstall
```

**Note:** The HPOM DVD content includes a default `ovoinstall` script. To successfully install HPOM on RHEL 7.x, make sure that you perform these steps:

- i. Replace the default `ovoinstall` with the `ovoinstall` downloaded from:

[https://softwaresupport.hpe.com/group/softwaresupport/search-result/-/facetsearch/document/KM02669472?lang=en&cc=us&hpappid=202392\\_SSO\\_PRO\\_HPE](https://softwaresupport.hpe.com/group/softwaresupport/search-result/-/facetsearch/document/KM02669472?lang=en&cc=us&hpappid=202392_SSO_PRO_HPE)

- ii. Run the latest `ovoinstall` downloaded from the above link, to start the HPOM installation.

The following text is displayed:

```
Welcome to the HP Operations Manager for UNIX installation
```

4. You are prompted to enter the HPOM software package repository location where all server packages are located.
5. Press **ENTER** to verify that you want the installation procedure to start.
6. Press **ENTER** to accept the default repository location, or enter the desired location followed by **ENTER**.

The `ovoinstall` script checks and installs the server setup package that contains the server installation infrastructure.

7. Press **ENTER** to continue with checking the system.

The following is checked:

- root user
- LANG
- NLS\_LANG
- umask
- Language
- Kernel parameters
- RAM and swap space
- Free disk space
- Operating system patches
- Installed software
- Running processes
- Required files
- Required file systems

**Note:** If the system check returns a failed value, type `back` and repeat the step, type `exit` and cancel the procedure, or type `?` and gain more information.

In case of a minimum deviation from the requirements, you can safely continue with the installation.

8. After the system check is done, press **ENTER** to continue with the installation.  
You are prompted to enter the HP Operations agent software location.
9. After you enter the HP Operations agent software location, press **ENTER**.  
You are prompted to enter the HPOM Administration UI software location.
10. After you enter the HPOM Administration UI software location, press **ENTER**.  
The `ovoinstall` script continues with installing the local agent.
11. After the process of installing the local agent returns the OK value, press **ENTER** to continue.  
The `ovoinstall` script continues with checking core component packages, server packages, localization packages, and ECS Composer packages.
12. Press **ENTER** to continue with installing the packages.



After all the packages are installed, the `ovoinstall` script installs all updates, finishes the server software installation, and displays the following note:

Before continuing with the server configuration, you can manually install available server patches.

13. *Optional:* Install the patches.

a. Open a second window and install the latest versions of the following patches:

- o Consolidated Server and Java GUI
- o Core and Accessories

b. Close the second window after you have successfully installed the patches. Return to the original window to continue with the upgrade.

14. Press **ENTER** to continue with the server software configuration.

The following text is displayed:

```
Welcome to the HP Operations Manager for UNIX configuration
```

15. Press **ENTER** to continue with checking the lock file and the system. If a specific system check is skipped, it means that it is already checked and is OK.

16. After the system check is done, press **ENTER**.

The `ovoconfigure` script continues with detecting special environments.

When the detection procedure finishes, you are prompted to enter the certificate backup password—the password used for a certificate backup and restore (for example, `cert_bkp`).

17. Accept the default value by pressing **ENTER**, or type the desired value followed by **ENTER**.

The `ovoconfigure` script asks you if you want to configure HP Performance Manager (OVPM).

18. Press **ENTER** to accept the default value and not to configure OVPM, or press **y** followed by **ENTER** to configure OVPM during the server configuration. In that case, specify OVPM's network node and port.

**Note:** OVPM can be configured after the server configuration.

The summary of the provided answer or answers appears.

19. Press **ENTER** to continue.

The `ovoconfigure` script continues with adding the `opc_op` user, creating the Instant-On license, and setting the embedded licensing configuration.

20. Press **ENTER** to continue.

The following question is displayed:

```
Configure the database?
```

21. Press **ENTER**.

**Caution:** At this point, you must decide which database you want to configure, an Oracle database or a PostgreSQL database.

The following question is displayed:

Will HPOM run on an Oracle instance (n for PostgreSQL)?

22. Press **ENTER** to accept the default value and continue with configuring an Oracle database, or press **n** followed by **ENTER** and continue with configuring a PostgreSQL database.

Depending on which database you choose to configure, make sure that you answer one of the following two sets of questions before continuing with the next step:

- *To configure an Oracle database:* ["Configuring an Oracle Database" on page 53](#)
- *To configure a PostgreSQL database:* ["Configuring a PostgreSQL Database" on page 55](#)

**Note:** When choosing a password for an HPOM database, avoid using a straight quotation mark ("), a single quotation mark ('), a dollar sign (\$), and a backslash (\). However, if you want your password to contain ', \$, or \, you can change it later by using the `opcdbpwd` command.

After you answer all the Oracle or PostgreSQL database-related questions, the `ovoconfigure` script checks the database configuration data and the summary of all provided answers appears.

23. Check the summary data, and then press **ENTER** to perform the database configuration.

**Caution:** If the database configuration fails, you can reconfigure the database by typing one of the following:

- **back:** All the questions related to the database configuration must be answered once again.
- **repeat:** Answers that you provided for the database configuration are reused.

In this case, you may be asked the following questions:

- Do you want to clear DB tables?  
Press **y** followed by **ENTER** if you want to clear all the tables, but not to drop the entire database.
- Do you want to completely drop the DB?  
Press **y** followed by **ENTER** if you want to completely drop the database and reconfigure it.

It is recommended that you answer **n** to the above questions if the database is configured manually or as a remote database. Make sure that you solve the problems manually before starting the database reconfiguration.

The entire database configuration procedure is written in the log files, which you can view at any time during the database configuration. For more information, see "[Viewing the Installation Log Files](#)" on page 59.

24. Press **ENTER** to continue with the server initialization.

During the server initialization, the `ovoconfigure` script performs the integration into the start/stop sequence.

25. Press **ENTER** to continue with the server final configuration that consists of the following:

- Assigning the management server policy group
- Configuring subagents
- Configuring the Java GUI
- Configuring the web server
- Backing up certificates
- Starting the server
- Installing agent deployment packages
- Configuring the local agent
- Distributing configuration to the local agent

26. If you want to enable the Event Storm Filter component, press **ENTER**. Otherwise, press **n** followed by **ENTER**.

For detailed information about the Event Storm Filter component, see the *HPOM Administrator's Reference*.

27. If you want to enable the Health Check component, press **ENTER**. Otherwise, press **n** followed by **ENTER**.

For detailed information about the Health Check component, see the *HPOM Administrator's Reference*.

The `ovoconfigure` script continues with installing server add-on packages.

28. Press **ENTER** to confirm that you want to install the server add-on packages.

After the server add-on packages are installed, the `ovoconfigure` script starts the Administration UI installation and you are prompted to answer the questions listed in [Table 7](#) by either accepting the default value and pressing **ENTER**, or typing the desired value followed by **ENTER**.

Table 7: Administration UI-related Questions

Question	Description and/or Default Value
Administration UI server ID	Unique identifier of the HP Operations management server.
Administration UI port	Web application port to which you connect with the web browser. The default value is 9662.
Administration UI secure port	Web application secure port to which you connect with the web browser. The default value is 9663.  It is not possible to disable either port. If you enter a non-default port number, you must also specify the alternate port number in the URL, which is used to invoke the Administration UI Web Application from the web browser.
Administration UI XML DB password	Password for the XML database. It stores the Administration UI users, user groups, user roles, and so on.
Database opc_op password	The password for the <code>opc_op</code> database user. The default value is <code>opc_op</code> .

After the Administration UI is successfully installed, the `ovoconfigure` script asks you if you want to switch HPOM to non-root operation.

29. If you want to switch HPOM to non-root operation, press **y** followed by **ENTER**. Otherwise, accept the default value **n** by pressing **ENTER**.

**Caution:** Switching HPOM to non-root operation is not supported in cluster environments.

Keep in mind that switching HPOM to non-root operation may take some time to complete.

For detailed information about non-root operation, see the *HPOM Concepts Guide*. For details about how to configure the Administration UI for non-root operation, see the *HPOM Administrator's Reference*.

30. *Optional:* Install the latest Administration UI patch.
31. *Optional:* Check if the installation of the HPOM software on the management server was successful.

For more information, see ["Starting HPOM and Verifying the Installation" on page 59](#).

32. Unmount the DVD-ROM drive by running the following command:

```
umount /<mount_point>
```

33. Make the HPOM manual pages available for users by adding the /opt/OV/man directory to the MANPATH environment variable. To do so, run the following commands:

```
MANPATH=$MANPATH:/opt/OV/man
export MANPATH
```

The MANPATH environment variable must be set either for a particular user in the .profile file, or for all users in the /etc/profile file.

**Note:** It is recommended to set the PATH variable to include the following HPOM directories on the management server: /opt/OV/bin, /opt/OV/bin/OpC, /opt/OV/nonOV/perl/a/bin, and /opt/OV/bin/OpC/utlis.

34. *Optional:* If you want to use hpterm for running Input/Output applications, run the following command:

```
ln -s /usr/contrib/bin/X11/hpterm /usr/bin/X11/hpterm
```

## Configuring an Oracle Database

This section describes Oracle database-related questions that appear during the installation and configuration of the HPOM software.

**Caution:** After you answer all the Oracle database-related questions, continue with the HPOM installation and configuration steps on page 50.

Table 8 shows which questions you must answer if you use the Oracle database with HPOM.

Table 8: Oracle Database-related Questions

Question	Description and/or Default Value
Enable automatic database startup?	y
Clear and re-initialize the tables if already exist?	y
Set up the database manually (local/remote)?	<p>This question allows you to choose how to create the database, manually or automatically.</p> <ul style="list-style-type: none"> <li>• If you want to create the database manually, press <b>y</b> followed by <b>ENTER</b>. In this case, the ovoconfigure script pauses instead of creating the database, allowing you to manually create the database. After you create the database manually</li> </ul>

Oracle Database-related Questions, continued

Question	Description and/or Default Value
	<p>as described in "<a href="#">Setting Up HPOM with a Remote/Manual Oracle Database</a>" on page 86, the <code>ovoconfigure</code> script configures HPOM to use the created database.</p> <ul style="list-style-type: none"> <li>If you want the <code>ovoconfigure</code> script to create the database automatically, press <b>ENTER</b> to accept the default answer.</li> </ul>
<p>Configure the database automatically for remote login?</p>	<p><i>Appears only if the database is created automatically.</i></p> <p>The default answer is <code>y</code>. If you choose the default answer, the database installation program creates an Oracle password file and gives proper rights to the <code>SYSTEM</code> database user so that the Oracle Remote Manager (RMAN) can access the database during the execution of backup or restore scripts.</p> <p>If you answer <code>n</code> to this question, you can grant these permissions manually.</p> <p>For detailed information about backing up data on the management server, see the <i>HPOM Administrator's Reference</i>.</p>
<p>Oracle Base</p>	<p>The Oracle database base directory, which is usually the same as the <code>ORACLE_BASE</code> variable. The default is <code>/opt/oracle</code>.</p>
<p>Oracle Home</p>	<p>The Oracle database home directory, which is usually the same as the <code>ORACLE_HOME</code> variable. The default is <code>/opt/oracle/product/11.1.0</code>.</p>
<p>Oracle User</p>	<p>The Oracle user for the HP Operations management server database. The default is <code>oracle</code>.</p>
<p>Oracle SID</p>	<p>The Oracle SID of the HP Operations management server database. The default is <code>openview</code>.</p> <p>The <code>ovoinstall</code> script uses this value also as the database name if it is not created manually. Therefore, the SID value is limited to a maximum length of 8 characters.</p>
<p>Oracle Data Directory</p>	<p>The directory where the HP Operations management server database files are stored (for example, <code>/opt/oracle/oradata</code>).</p>
<p>Oracle Index Directory</p>	<p>The directory where the HP Operations management server database index files are stored. By default, this directory is the</p>

Oracle Database-related Questions, continued

Question	Description and/or Default Value
	same as the Oracle data directory.
Oracle User opc_op Password	The password for the opc_op database user. The default is opc_op.
Oracle User opc_report Password	The password for the opc_report database user. The default is opc_report.
Oracle User system Password	The password for the system database user. The default is manager.
Database Character Set (NLS_LANG)	Type the desired NLS_LANG value in the <Lang>_<region>.AL32UTF8 form. The default value is american_america.AL32UTF8.
Oracle Listener Name	LISTENER
Oracle Listener Port	1521
Oracle Net Service Name	ov_net

## Configuring a PostgreSQL Database

This section describes PostgreSQL database-related questions that appear during the installation and configuration of the HPOM software.

**Caution:** After you answer all the PostgreSQL-database related questions, continue with the HPOM installation and configuration steps on page 50.

To start configuring a PostgreSQL database, answer the following question:

Do you wish HPOM to manage the PSQL cluster?

Depending on whether you want to have a managed database (HPOM manages a local database that will be created from the beginning or was created by using the `psqlcluster` tool) or an independent database (HPOM connects to an independent local or remote database, but does not manage it), press one of the following two keys, and then carefully follow the instructions:

- **y:** See ["Managed PostgreSQL Database" on the next page](#).
- **n:** See ["Independent PostgreSQL Database" on page 58](#).

**Note:** If the independent database is not created, the `ovoconfigure` script pauses, allowing you to manually create the database.

Regardless of whether you choose `y` (the default answer) or `n`, the following question is displayed:

Clear and reinitialize the tables if they already exist?

## Managed PostgreSQL Database

If the database is managed, you must choose a PostgreSQL cluster directory where you want the database to be created (it must be non-existent or empty) or where the database was created by using the `psqlcluster` tool. Answer the following question:

PSQL cluster directory?

After you choose the PostgreSQL cluster directory, the `ovoconfigure` script checks it. Depending on whether this directory is empty or non-existent, or it belongs to an HPOM-created cluster, you must answer either the questions described in [Table 9](#) and [Table 10](#).

## PostgreSQL Cluster Directory Is Empty or Non-Existent

[Table 9](#) shows which questions you must answer if the PostgreSQL cluster directory is empty or non-existent.

Table 9: PostgreSQL Database-related Questions If the Cluster Directory Is Empty or Non-Existent

Question	Description
PSQL binary directory	The directory where the PostgreSQL binaries are stored. Keep in mind that the location of this directory varies depending on the distribution or the version.
PSQL library directory	The directory where the PostgreSQL client libraries are stored. Keep in mind that the location of this directory varies depending on the distribution or the version.
PSQL data directory	The directory where the data tablespaces are stored. This directory must be empty or non-existent. If you do not provide an answer to this question, <code>&lt;cluster_dir&gt;/HPOM</code> is used.
PSQL index directory	The directory where the index tablespaces are stored. This directory must be empty or non-existent. If you do not provide an answer to this question, <code>&lt;cluster_dir&gt;/HPOM</code> is used.
Do you wish to start the PSQL cluster	Press <code>y</code> if you want the database cluster to be started automatically each time the system is started. Otherwise, you must start the



PostgreSQL Database-related Questions If the Cluster Directory Is Empty or Non-Existent, continued

Question	Description
automatically at boot time?	database cluster manually before you can start HPOM.
Hostname	The system on which the database cluster or server is installed.
Port	The port on which the database cluster or server listens. It is usually set to 5432 or 5444.  Make sure no other process uses this port at any time, including after a system restart.
Database name	The name of the HPOM database. The default is <code>openview</code> .
OS DBA user	The operating system user that controls database processes and has access to all PostgreSQL binaries and HPOM database directories. This user is usually set to <code>postgres</code> .
DB DBA user	The name of the administrator user inside the database cluster or server, which is usually set to <code>postgres</code> .
DB DBA user password	The password of the administrator user inside the database cluster or server, which is usually set to <code>postgres</code> .
Database <code>opc_op</code> password	The password for the <code>opc_op</code> database user. The default is <code>opc_op</code> .
Database <code>opc_report</code> password	The password for the <code>opc_report</code> database user. The default is <code>opc_report</code> .

PostgreSQL Cluster Directory Belongs To an HPOM-created Cluster

Table 10 lists the questions that you must answer if the PostgreSQL cluster directory belongs to an HPOM-created cluster.

Table 10: PostgreSQL Database-related Questions If the Cluster Directory Belongs To an HPOM-created Cluster

Question	Description
PSQL library directory	The directory where the PostgreSQL client libraries are stored. Keep in mind that the location of this directory varies depending on the distribution or the version.
Hostname	The system on which the database cluster or server is installed.

### PostgreSQL Database-related Questions If the Cluster Directory Belongs To an HPOM-created Cluster, continued

Question	Description
Database name	The name of the HPOM database. The default is <code>openview</code> .
Database <code>opc_op</code> password	The password for the <code>opc_op</code> database user. The default is <code>opc_op</code> .
Database <code>opc_report</code> password	The password for the <code>opc_report</code> database user. The default is <code>opc_report</code> .

## Independent PostgreSQL Database

[Table 11](#) lists the questions that you must answer if the PostgreSQL database is independent.

Table 11: Independent PostgreSQL Database-related Questions

Question	Description
PSQL binary directory	The directory where the PostgreSQL binaries are stored. Keep in mind that the location of this directory varies depending on the distribution or the version.
PSQL library directory	The directory where the PostgreSQL client libraries are stored. Keep in mind that the location of this directory varies depending on the distribution or the version.
Hostname	The system on which the database cluster or server is installed.
Port	The port on which the database cluster or server listens. It is usually set to 5432 or 5444.  Make sure no other process uses this port at any time, including after a system restart.
Database name	The name of the HPOM database. The default is <code>openview</code> .
DB DBA user	The name of the administrator user inside the database cluster or the server. It is usually set to <code>postgres</code> .
DB DBA user password	The password of the administrator user inside the database cluster or the server. It is usually set to <code>postgres</code> .
Database <code>opc_op</code> password	The password for the <code>opc_op</code> database user. The default is <code>opc_op</code> .

### Independent PostgreSQL Database-related Questions, continued

Question	Description
Database opc_report password	The password for the opc_report database user. The default is opc_report.

## Viewing the Installation Log Files

When you install the HPOM software, you can verify if the installation was successful by checking the end of the `/var/opt/OV/log/OpC/mgmt_sv/ovoinstall.log` log file. Either open the log file using a text editor or type the following:

```
more /var/opt/OV/log/OpC/mgmt_sv/installation.log  
more /var/opt/OV/log/OpC/mgmt_sv/installation.log.verbose
```

You can also check for errors by viewing the analysis and installation log files during the installation. Enter the following in a new terminal window:

```
tail -f /var/adm/sw/swagent.log
```

## Administration UI Installation Log File

If you want to view only the information about the Administration UI part of the installation process, you can check log files created in the `/opt/OV/OMU/adminUI/` directory. The format of these log files is as follows:

```
HPOM_Administration_UI_Install_<date_time>.log
```

For example:

```
HPOM_Administration_UI_Install_04_01_2014_16_00_23.log
```

## Starting HPOM and Verifying the Installation

To verify the HPOM installation, follow these steps:

1. As the root user, verify that all HP Operations server services are running by entering the following:

```
/opt/OV/bin/OpC/opcsv
```

An output similar to the following one should appear:

```
HPOM Management Server status:  
-----  
HPOM Administration UI Server      adminui      (29109) is running
```

```

OMU Action Manager          opcactm      (28339) is running
OMU BBC Config Adapter     opcbbcdist  (28385) is running
OMU Cert. Server Adapter   opccsad     (28431) is running
OMU Display Manager        opcdisp     (28249) is running
OMU Event Storm Filter     opcesf      (29018) is running
OMU Forward Manager        opcforwm    (28476) is running
OMU Health Check           opchcd      (29069) is running
OMU Health Monitoring Engine opchealth   (28880) is running
OMU Message Manager        opcmsgm     (28521) is running
OMU Message Receiver (HTTPS) opcmsgrb    (28569) is running
OMU Svc. Nav. Action Manager opcsvcam    (28833) is running
OMU Service Discovery Server opsvcdisc   (28956) is running
OMU Service Engine         opsvcm      (28613) is running
OMU TT & Notify Manager     opcttnsm    (28658) is running
OMU HTTPS Communication Proxy opcuhttps   (28789) is running
OMU Request Sender         ovoareqsdr  (28293) is running
    
```

OV Control Core components status:

-----

```

OV Communication Broker    ovbbccb     (25735) is running
OV Control                  ovcd        (25734) is running
OV Certificate Server       ovcs        (28203) is running
OV Tomcat(B) Servlet Container ovtomcatB   (26847) is running
    
```

If the HP Operations management server services are not running, you can start them with the following command:

```
/opt/OV/bin/OpC/opcsv -start
```

**Caution:** You must have a local agent installed to perform steps 2 and 3.

2. Verify that all the HP Operations agent services are running on the management server system by running the following command:

```
/opt/OV/bin/OpC/opcagt -status
```

An output similar to the following one should appear:

```

scopeux    Perf Agent data collector          (3937)  Running
midaemon   Measurement Interface daemon       (3854)  Running
ttd        ARM registration daemon            (3852)  Running
perfalarm  Alarm generator                     (5947)  Running
perfd      real time server                    (3823)  Running
coda       OV Performance Core                COREXT  (26444) Running
opcacta    OVO Action Agent                   AGENT,EA (26462) Running
opcmona    OVO Monitor Agent                  AGENT,EA (26467) Running
opcmsga    OVO Message Agent                  AGENT,EA (26453) Running
opcmsgi    OVO Message Interceptor            AGENT,EA (26464) Running
ovbbccb    OV Communication Broker             CORE     (25735) Running
    
```

```

ovcd          OV Control          CORE          (25734)  Running
ovconfd      OV Config and Deploy  COREEXT      (26430)  Running

```

If the HP Operations agent services are not running, you can start them with the following command:

```
/opt/OV/bin/OpC/opcagt -start
```

3. Submit test messages by typing the following:

```
/opt/OV/bin/OpC/utlils/submit.sh
```

This program sends simulated messages to the message browser. The number of messages received depends on the configuration of your system. Under normal conditions, you will usually receive at least two messages.

4. Complete one of the following tasks to be able to test and use an application configured as Window (Input/Output) from the HPOM User's Assigned Applications window:

- As the `root` user, set the UNIX password for `opc_op` for each managed node where you want to use Input/Output applications.

To do this, type the following:

```
passwd opc_op
```

**Note:** By default, the `opc_op` user is not allowed to log on to the system (\* entry in the password field of `/etc/passwd`).

- Make sure the `$HOME/.rhosts` file exists on the managed node (`$HOME` is the home directory of `opc_op` on the managed node). If it does not exist, create it.

Make an entry in `.rhosts` for the `opc_op` user on the managed node. For example:

```
<management_server>.<domain> opc_op
```

It is not recommended to keep the `.rhosts` entry in a production environment because it can represent a security risk.

- Make sure the `/etc/hosts.equiv` file exists on the managed node. If it does not exist, create it.

Add the hostname of your management server to this file. For example:

```
<management_server>.<domain>.com
```

It is not recommended to keep the `/etc/hosts.equiv` entry in a production environment because it can represent a security risk.

## Creating Additional Database Users

After you complete the installation of HPOM, decide whether you want to create additional database users.

### Oracle Database Users

During the initial configuration setup, Oracle creates the `sys`, `system`, `outln`, and `dbsnmp` default users and gives them default passwords. Depending on the installed Oracle components and the version, you can create additional database users. These Oracle users are not used by HPOM.

You can change the passwords of these Oracle users with the Oracle tool, SQL\*Plus.

For example:

```
su - oracle
sqlplus /nolog
SQL> connect / as sysdba
SQL> alter user system identified by <new_password>
SQL> exit
exit
```

### PostgreSQL Database Users

A PostgreSQL cluster is created with a database superuser, usually named `postgres`. During the HPOM configuration, two additional database users are created, namely `opc_op` and `opc_report`.

You can choose the names for all the database users during the database creation or configuration, or you can change these names later on by running the following commands:

```
su - postgres
psql -U <DB_DBA_user> -h <hostname> -p <port>
postgres=# alter user <user> with password '<password>';
postgres=# alter user <user> valid until 'infinity';
postgres=# \q
exit
```

In this instance, `<DB_DBA_user>` is the name of the administrator user inside the database cluster or server, `<hostname>` is the system on which the database cluster or server is installed, and `<port>` is the port on which the database cluster or server listens.

**Caution:** Make sure that you change the password in the `~/ .pgpass` file of the operating system user. Otherwise, the HPOM scripts and programs may stop working.

## Reconfiguring the HPOM Software

If you want to reconfigure the HPOM software, run the HPOM configuration utility `ovoconfigure` as the root user on the management server.

If you want to use a separate system as the database server, first configure the database server system as described in ["Setting Up HPOM with a Remote/Manual Oracle Database" on page 86](#) or ["Setting Up HPOM with a Remote/Manual PostgreSQL Database" on page 98](#).

To reconfigure the HPOM software, follow these steps:

1. Make sure that the `LANG` environment variable is set to a UTF-8 locale.

For more information, see ["Configuring Input/Output for Multiple Language Support" on page 26](#).

To check the setting, type the following command:

```
echo $LANG
```

2. *For an Oracle database only:* Export all Oracle environment variables including `NLS_LANG`.

For instructions, see ["Before Installing an Oracle Database" on page 29](#).

**Note:** Make sure that you set the same `ORACLE_SID` value as the one you specified before running the `ovoinstall` script.

3. To start `ovoconfigure`, type the following:

```
/opt/OV/bin/OpC/install/ovoconfigure
```

For details, see ["Configuring an Oracle Database" on page 53](#) or ["Configuring a PostgreSQL Database" on page 55](#).

## Reconfiguring Database Connection Parameters

HPOM stores all the connection parameters needed to work with the database. When changing any of the database connection parameters, it is therefore important to update the HPOM configuration with the new values. Otherwise, connection problems and downtime may occur.

This section describes how to change your database password as well as how to reconfigure HPOM to work with a new database name.

## Changing a Database Password

**Caution:** You should change a database password only if necessary. For more information about changing the database password, see the *opcdbpwd* manual page.

Depending on your database type, see one of the following sections:

- ["Changing an Oracle Database Password" below](#)
- ["Changing a PostgreSQL Database Password" on the next page](#)

### Changing an Oracle Database Password

To change an Oracle database password, follow these steps:

1. Back up the following files:

```
/etc/opt/OV/share/conf/OpC/mgmt_sv/.opcdbpwd.sec  
/etc/opt/OV/share/conf/OpC/mgmt_sv/.opcdbpwd.rem
```

2. Change the Oracle database password by running one of the following commands:

- For the `opc_op` user:

```
/opt/OV/bin/OpC/opcdbpwd -set
```

- For any other user:

```
# su - oracle  
$ sqlplus /nolog  
SQL> conn / as SYSDBA  
SQL> alter user <user_name> identified by <new password>;  
SQL> commit;
```

3. *If you changed the password of the `opc_op` or `opc_report` user:* Make sure that you also update the Administration UI configuration.
4. *If you changed the password of the `SYSTEM (RMAN)` user:* Update the HPOM configuration by running the following commands:

```
RMAN_PASSWD=<new_password>  
export RMAN_PASSWD  
/opt/OV/bin/OpC/opcdbpwd -rpr  
unset RMAN_PASSWD
```



## Changing a PostgreSQL Database Password

To change a PostgreSQL password, follow these steps:

1. Back up the following files:

```
/etc/opt/OV/share/conf/OpC/mgmt_sv/.opcdbpwd.sec
```

```
/etc/opt/OV/share/conf/OpC/mgmt_sv/.opcdbpwd.rem
```

2. Back up the `.pgpass` file in the home directory of the operating system DBA user (usually `postgres`).
3. Log on to the PostgreSQL database as the `admin` user (for example, `postgres`).

**Note:** If you do not have access to the `admin` user, see the PostgreSQL documentation describing the `pg_hba.conf` file and how to temporarily disable authentication.

4. Connect to the database, and then change the PostgreSQL password by running the following commands:

```
psql -U <DB_DBA_user> -h <hostname> -p <port>
```

```
postgres=# ALTER USER <user> WITH ENCRYPTED PASSWORD '<password>';
```

5. *If you changed the `opc_op` user password:* Update the HPOM configuration by running the following commands:

```
OPC_OP_PASSWD=<new_password>
```

```
export OPC_OP_PASSWD
```

```
/opt/OV/bin/OpC/opcdbpwd -pre
```

```
unset OPC_OP_PASSWD
```

6. *If you changed the `DB DBA user` password:* Update the HPOM configuration by running the following commands:

```
RMAN_PASSWD=<new_password>
```

```
export RMAN_PASSWD
```

```
/opt/OV/bin/OpC/opcdbpwd -rpr
```

```
unset RMAN_PASSWD
```

7. Edit the `.pgpass` file in the home directory by replacing the old password with the new one, so that HPOM connects to the database with the new password. For details, see the PostgreSQL documentation.
8. *If you changed the password of the `opc_op` or `opc_report` user:* Make sure that you also update the Administration UI configuration.

## Reconfiguring HPOM to Work with a New Database Name

To reconfigure HPOM to work with a new database name, follow these steps:

1. Stop all HPOM and database processes.
2. Edit the `/etc/opt/OV/share/conf/ovdbconf` file as follows:
  - a. Navigate to the `DB_NAME` line.
  - b. In the `DB_NAME` line, replace the old database name with the new one.
3. Update the database name in the server configuration variables by running the following command:

```
/opt/OV/bin/ovconfchg -ovrg server -ns opc -set DATABASE <new_db_name>
```
4. Reconfigure the Administration UI as follows:
  - a. Edit the `ovodb.url` property in the `ovoinstall.properties`, `ovoconfig.properties`, `opccfg.properties`, and `ovoappl.properties` files as follows:
    - *Oracle:*

```
ovodb.url=jdbc:oracle:thin:@<db_server_hostname>:<db_port>:<db_name>
```
    - *PostgreSQL:*

```
ovodb.url=jdbc:postgresql://<db_server_hostname>:<db_port>/<db_name>
```In these instances, `<db_server_hostname>` is the hostname of the system where the remote database is located, `<db_port>` is the database port, and `<db_name>` is the name of the database.
  - b. Restart the Administration UI by running the following commands:

```
/opt/OV/OMU/adminUI/adminui clean  
/opt/OV/OMU/adminUI/adminui start
```
5. Make sure that all database-specific configuration files are also updated (for example, the listener files for the Oracle database or the `.pgpass` file for the PostgreSQL database).
6. Start all database and HPOM processes.

# Chapter 3: Installing the Java GUI

## In This Chapter

This chapter describes how to do the following:

- Install, configure, and start the Java GUI.
- Configure a web server to use customized icons and background graphics.

This chapter assumes that you already installed the HPOM software and that you have a supported web server, as described by the vendor of the server.

## Supported Platforms

The Java GUI is tested only on the operating system platforms listed in [Table 12](#), and is therefore supported only on these operating system platforms.

**Caution:** On all operating system platforms not listed in [Table 12](#), you run the Java GUI at your own risk. Running the Java GUI on a UNIX platform is not recommended because it can lead to performance problems.

Table 12: Supported Platforms of the Java GUI Client

| Supported Platforms  | Java Application | Java Applet <sup>a</sup> |
|--|------------------|--------------------------|
| HP-UX 11i v3 on HP Integrity                                   | yes              | yes                      |
| Mac OS X<br>Mac OS X running on Intel processors               | yes              | yes                      |
| RHEL 5.x, 6.x, and 7.x<br>Oracle Linux 6.x<br>CentOS Linux 6.x | yes              | yes                      |
| Solaris 10   | yes              | yes                      |
| Windows XP   | yes              | yes                      |

<sup>a</sup>For the list of supported web browsers, see ["Supported Web Browsers" on page 70](#).

### Supported Platforms of the Java GUI Client, continued

| Supported Platforms  | Java Application | Java Applet <sup>a</sup> |
|--|------------------|--------------------------|
| Windows 2003<br>Windows 2003 Server (64-bit)<br>Windows Vista<br>Windows 2008 R2 (64-bit)<br>Windows 7<br>Windows 8<br>Windows 8.1 |                  |                          |

For the most up-to-date list of supported platforms, see the support matrix at the following location:

<http://support.openview.hp.com/selfsolve/document/KM323488>

## Supported Languages

Table 13 shows a list of languages into which the Java GUI is translated.

Table 13: Supported Languages of the Java GUI Client

| Supported Platforms  | Language  |
|--|---|
| HP-UX 11i v3 on HP Integrity                                   | Japanese<br>Korean<br>Simplified Chinese<br>Spanish |
| Mac OS X<br>Mac OS X running on Intel processors               | Japanese<br>Korean<br>Simplified Chinese<br>Spanish |
| RHEL 5.x, 6.x, and 7.x<br>Oracle Linux 6.x<br>CentOS Linux 6.x | Japanese<br>Korean<br>Simplified Chinese<br>Spanish |
| Solaris 10   | Japanese<br>Korean<br>Simplified Chinese<br>Spanish |

<sup>a</sup>For the list of supported web browsers, see "Supported Web Browsers" on page 70.

### Supported Languages of the Java GUI Client, continued

| Supported Platforms          | Language           |
|------------------------------|--------------------|
| Windows XP                   | Japanese           |
| Windows 2003                 | Korean             |
| Windows 2003 Server (64-bit) | Simplified Chinese |
| Windows Vista                | Spanish            |
| Windows 2008 R2 (64-bit)     |                    |
| Windows 7                    |                    |
| Windows 8                    |                    |
| Windows 8.1                  |                    |

For the most up-to-date list of supported platforms, see the support matrix at the following location:

<http://support.openview.hp.com/selfsolve/document/KM323488>

When starting the Java GUI, select the correct locale. The locale influences the sorting, the text display, and the representation of date and time. It also selects the localized files for your installation.

For example, to start the Spanish Java GUI, select Spain (Spanish) in the log-on window.

## Installation Requirements

This section describes the hardware and software requirements for installing the Java GUI, as well as web browsers supported by the product.

### Hardware Requirements

- **UNIX or Linux**

For more information, see "[Installation Requirements for the Management Server](#)" on page 13.

- **Windows**

The best performance is achieved with an x86-based PC with a processor of at least 1 Ghz, a minimum of 256 MB RAM, and additional 30MB RAM per GUI session.

### Software Requirements

Make sure the following requirements are met:

- The management server system meets software requirements described in "[Installation Requirements for the Management Server](#)" on page 13.

**Note:** The kernel parameter that defines the maximum number of file descriptors per process must be adjusted to ensure good performance.

- HPOM software is installed on the management server.
- One of the following JREs is installed on the system where the Java GUI will be installed and running:
  - JRE 7:
    - *HP-UX, Linux, and Solaris:* JRE 7u25 or higher
    - *Windows:* JRE 7u51 or higher
    - *Mac OS X:* JRE 7u55 or higher

- JRE 8u31 or higher

If you want to use JRE 8, download and install it from either Oracle's Java web site (<http://www.oracle.com/technetwork/java/index.html>) or your platform repositories.

For the most up-to-date list of supported JRE versions, see the support matrix at the following location:

<http://support.openview.hp.com/selfsolve/document/KM323488>

**Note:** The HPOM installation automatically installs and configures Tomcat web server version 7 on the management server.

## Supported Web Browsers

If you want to run the Java GUI as an applet from a web browser or if you want to use the online documentation supplied with the Java GUI, you should have one of the following web browsers installed:

- Microsoft Internet Explorer 9 or higher
- Mozilla Firefox 24 or higher
- Chrome 32 or higher
- Safari 6 or higher

**Note:** If you want to use the cockpit view client, make sure that your browser has Adobe Flash Player 10 or higher with ActiveX installed as a plug-in.

For the most up-to-date list of supported web browser versions and architectures, see the support matrix at the following location:

<http://support.openview.hp.com/selfsolve/document/KM323488>

**Note:** The valid browsers are browsers with ActiveX and external browsers. On UNIX, only an external browser can be used. On Windows, a browser with ActiveX is the default browser.

## Installing the Java GUI

You can either run the Java GUI directly on your management server system or use HTTP or FTP to transfer Java GUI binaries from the management server to the system where the Java GUI will be running.

The HP Operations management server installation automatically installs the Java GUI binaries into the `/opt/OV/www/htdocs/ito_op/` directory on the management server.

## Installing the Java GUI Through HTTP

To install the Java GUI through HTTP, follow these steps:

1. Make sure that an HTTP server is installed and running.

If you are using the HPOM Tomcat server, the `ovtomcatB` process must be running. To check if the `ovtomcatB` process is running, type the following:

```
/opt/OV/bin/ovc -status WEB
```

If the `ovtomcatB` process is not running, you can start it by typing the following command:

```
/opt/OV/bin/ovc -start WEB
```

2. On the system where the Java GUI will be running, enter one of the following URLs in a web browser:

```
http://<management_server>:8081/ITO_OP
```

```
https://<management_server>:8444/ITO_OP
```

In these URLs, `<management_server>` is the fully qualified hostname of your management server.

3. Follow the instructions on the web page:

- *Installation on a Windows system:*  
Download and execute the `ITO_JAVA.exe` file.
- *Installation on an HP-UX, Solaris, Linux, or Mac OS X system:*  
Download and untar the `ito_op_install.tar` file.

## Installing the Java GUI Through FTP

To install the Java GUI through FTP, follow these steps:

1. Transfer the files through FTP by following these steps:
  - a. Open a command prompt or a terminal window on the system where the Java GUI will be installed.
  - b. Start an FTP connection to the HP Operations management server by typing the following:  

```
ftp <management_server>
```

In this instance, *<management\_server>* is the hostname of your management server.
  - c. Make sure that the binary mode is used by typing the following:  

```
bin
```
  - d. Move to the directory where the Java GUI software is located by running the following command:  

```
cd /opt/OV/www/htdocs/ito_op
```

Obtain the Java GUI executable by running one of the following commands:
    - *For a Windows system:*  

```
get ITO_JAVA.exe
```
    - *For a UNIX-based system:*  

```
get ito_op_install.tar
```Close the FTP connection when the files are transferred.
2. Extract the software from the files by running one of the following commands:
  - *For a Windows system:*  

```
<drive_letter>:ITO_JAVA.exe
```

This starts the installation wizard that guides you through the installation.
  - *For a UNIX-based system:*  

```
tar xvf ito_op_install.tar
```

## Installing the Java GUI from the Installation Media

On HP-UX 11i systems other than HP Operations management servers, use the `swinstall` tool to install the Java GUI client. The `swinstall` tool is supplied with the operating system.

To install the Java GUI on HP-UX 11i systems by using the `swinstall` tool, follow these steps:

1. For all languages, run the following command:  

```
swinstall -s /<mount_point>/packages/HPOVOUwwwGui.depot \  
HPOVOUServer.HPOVOUwwwGUI
```
2. For each language respectively, run the following command:



- **English:**

```
swinstall -s /<mount_point>/packages/HPOvOUwwwEng.depot \  
HPOvOUsServer.HPOVUWWWENG
```

- **Spanish:**

```
swinstall -s /<mount_point>/packages/HPOvOUwwwSpa.depot \  
HPOvOUsServer.HPOVUWWWSPA
```

- **Japanese:**

```
swinstall -s /<mount_point>/packages/HPOvOUwwwJpn.depot \  
HPOvOUsServer.HPOVUWWWJPN
```

- **Korean:**

```
swinstall -s /<mount_point>/packages/HPOvOUwwwKor.depot \  
HPOvOUsServer.HPOVUWWWKOR
```

- **Simplified Chinese:**

```
swinstall -s /<mount_point>/packages/HPOvOUwwwSch.depot \  
HPOvOUsServer.HPOVUWWWSCH
```

In these instances, *<mount\_point>* is the location where the HPOM installation DVD is mounted.

## Starting the Java GUI

This section describes how to start the Java GUI (and consequently Service Navigator) on a Windows system, on a UNIX-based system, and from a web browser.

**Note:** To log on to the Java GUI for the first time, use default users and passwords. The default log-on passwords are as follows:

- For administrators: OpC\_adm
- For operators: OpC\_op

The next time you log on, you should change your default password for security reasons. You can change your password again later, but you will not be allowed to set the password back to the default one.

If you want to access web pages that start Java applets in a workspace, the Java GUI must be running as an applet. For more information about starting the Java GUI as an applet, see ["Starting the Java GUI from a Web Browser" on page 75](#).

Make sure you use the proper LANG variable when starting the Java GUI in languages other than English. Starting the Java GUI by using the English locale C and then switching to the other language

may result in incorrectly displayed accentuated characters in some dialog boxes and in displaying garbage characters in the window title.

## ito\_op Startup Script

The `ito_op` startup script first reads the environment variables, then evaluates the command line options, and finally the preferences listed in the `itoopec` file.

For more information about the `ito_op` script, see the *ito\_op(1M)* manual page (UNIX), the `ito_op.bat` script (Windows), and the *HPOM Administrator's Reference*.

## Starting the Java GUI on a Windows System

The install shield of the Java GUI client software installs a desktop shortcut for the GUI.

To start the Java GUI on a Windows system, follow these steps:

1. Do one of the following:
  - Use the installed desktop shortcut.
  - Enter the following:  

```
<drive_letter>:\<install_directory>\ito_op.bat
```

The Java GUI starts and displays a log-on screen.

2. Enter the HPOM user name and password.

**Note:** The user name can contain Unicode characters.

3. Enter the management server hostname.

## Starting the Java GUI on a UNIX-based System

To start the Java GUI on a UNIX-based system, follow these steps:

1. Export the `DISPLAY` environment variable if needed.
2. Enter the following:  

```
/opt/OV/www/htdocs/ito_op/ito_op &
```

The Java GUI starts and displays a log-on screen.
3. Enter the HPOM user name and password.

**Note:** The user name can contain Unicode characters.

## Starting the Java GUI from a Web Browser

**Note:** You do not need to install the GUI if you want to start the Java GUI from a web browser. Simply download the Java applet provided with the GUI client software.

To start the Java GUI from a web browser, follow these steps:

1. Make sure that all the prerequisites are met as described in "[Installation Requirements](#)" on page 69.
2. On the system where the Java GUI will be running, open one of the following URLs in a web browser:

`http://<management_server>:8081/ITO_OP`

`https://<management_server>:8444/ITO_OP`

In these URLs, `<management_server>` is the fully qualified hostname of your management server.

3. Follow the instructions given on the web page for downloading the Java applet.

## Connecting Through a Firewall

If you want to access the HP Operations management server with the Java GUI from outside a firewall, open port 35211. Port 35211 is the socket used by the Java GUI to connect to the management server.

## Configuring the HTTP Server

Install your web server as described in the vendor's documentation and verify that the web server is running properly.

If you want to install and access the Java GUI, you must configure your HTTP server. The configuration varies depending on the type of HTTP server.

The following web servers are supported:

- Apache Tomcat (automatically installed and configured with the HPOM installation)
- Netscape

For details about configuring a Netscape web server, see "[Configuring a Netscape Web Server](#)" on the next page.

- W3C Jigsaw

For details about configuring a W3C Jigsaw web server, see "[Configuring a W3C Jigsaw Web Server](#)" below.

## Configuring a Netscape Web Server

To configure Netscape for installing and accessing the Java GUI, follow these steps:

1. Select the Netscape web server that you want to configure.
2. From Netscape Enterprise Configuration, do the following:
  - a. Click the **Content mgmt** button at the top of the window.
  - b. Select **Additional Document Directories** from the left side of the window.
  - c. For URL prefix, enter:  
`ITO_OP/`
  - d. For Map To Directory, enter:  
`/opt/OV/www/htdocs/ito_op`
  - e. Click **OK**.
  - f. Click **Save and Apply**.

Restart your web server, and then open one of the following URLs:

```
http://<server_hostname>:8081/ITO_OP/  
https://<server_hostname>:8444/ITO_OP/
```

In these URLs, *<server\_hostname>* is the hostname of your web server, including the domain.

3. Make sure the .exe extension is defined in the `/opt/ns-fasttrack/httpd-<server_hostname>/config/mime.types` file by adding the following line:  
`type=application/octet-stream exts=exe`

## Configuring a W3C Jigsaw Web Server

To configure a W3C Jigsaw web server for installing and accessing the Java GUI, follow these steps:

1. Add the following line to the `httpd.conf` file:  
`Pass /ITO_OP/* /opt/OV/www/htdocs/ito_op/*`
2. Restart the web server.
3. Open the following URL:

```
http://<server_hostname>/ITO_OP/
```

In this instance, *<server\_hostname>* is the hostname of your web server, including the domain.

# Chapter 4: Service Management and Database Configuration

## In This Chapter

This chapter describes how to do the following:

- Set up startup and shutdown operations for the HP Operations management server services.
- Start and stop a database automatically.
- Start and stop a database manually.
- Replace an HPOM database.
- Set up HPOM with a remote/manual database.
- Set up HPOM in an Oracle Real Application Clusters (RAC) environment.

## Starting and Stopping HPOM

When you configure HPOM, the startup of the HPOM processes is automatically integrated into the system boot sequence.

You can, however, start the HP Operations management server services by using the `opcsv -start` command. Similarly, you can stop the HP Operations management server services by using the `opcsv -stop` command.

The `opcsv` command is located in the `/opt/OV/bin/OpC` directory and has the following functions:

|                            |  |
|----------------------------|--|
| <code>opcsv -start</code>  | Starts the HP Operations management server processes.                                  |
| <code>opcsv -stop</code>   | Stops the HP Operations management server processes.                                   |
| <code>opcsv -status</code> | Displays detailed status information on the HP Operations management server processes. |

The `opcsv` command does not start and stop the subagent processes. The subagent communication processes are managed by the `ovc` command, which is located at `/opt/OV/bin`. If you want to stop the HP Operations agent processes, use `ovc -stop AGENT`. If you want to start the HP Operations agent processes, use `ovc -start AGENT`.

For more information about the `opcsv` and `ovc` commands, see the `opcsv(1)` and `ovc(1M)` manual pages.

**Tip:** If you experience communication problems between the HP Operations server and agents, or if the server processes are not correctly informed about configuration changes, restart both the HP Operations management server and HP Operations agent processes:

```
/opt/OV/bin/ovc -stop SERVER AGENT  
/opt/OV/bin/ovc -start SERVER AGENT
```

## Starting and Stopping a Database Automatically

HPOM can be configured to start or stop the database automatically whenever you start up and shut down the HP Operations management server.

## Starting and Stopping an Oracle Database Automatically

To ensure an automatic startup and shutdown of the Oracle database whenever you start up and shut down the HP Operations management server, use the `/sbin/init.d/ovoracle` script. If you choose to start the HP Operations management server processes automatically at startup, make sure that the Oracle database is started before HPOM.

The option for the automatic startup and shutdown of the database is set in the following file:

```
/etc/rc.config.d/ovoracle
```

Change the `OVORACLE` and `OVORALISTENER` variables to 1, as shown in the following extract from the file:

```
# configure if oracle database should be started  
# 0 - do not start  
# 1 - start  
# default is 0. This may be changed here manually  
#  
OVORACLE=1  
OVORALISTENER=1
```

## Starting and Stopping a PostgreSQL Database Automatically

To ensure an automatic startup and shutdown of the PostgreSQL database whenever you start up and shut down the HP Operations management server, use the `/sbin/init.d/ovopsql` script. If you choose to start the HP Operations management server processes automatically at startup, make sure that the PostgreSQL database is started before HPOM.

The `ovopsql` script is configured to run at startup and it reads the `/etc/ovopsql` configuration file containing a list of database clusters that are started automatically. The configuration file is automatically updated when you create a database cluster by using `psqlcluster -ar`, but you can also customize it by editing the configuration file manually.

**Note:** If you want to start and stop a remote PostgreSQL database automatically, you must install the `HP0vOUPSQlConf` package. For details, see ["Installing and Configuring HPOM with a Remote/Manual PostgreSQL Database" on page 104](#).

## Starting and Stopping a Database Manually

If you choose not to incorporate the database startup and shutdown commands in the system boot sequence, you must start and stop the database manually.

**Caution:** Start the database before starting HPOM and stop the database after stopping HPOM.

## Starting and Stopping an Oracle Database Manually

Depending on whether you want to start or stop an Oracle database manually, follow the steps described in one of the following sections:

- ["Starting an Oracle Database Manually" below](#)
- ["Stopping an Oracle Database Manually" on the next page](#)

### Starting an Oracle Database Manually

To start an Oracle database manually, follow these steps:

1. Switch to the `oracle` user:  
`su - oracle`

2. Set the *ORACLE\_HOME* environment variable.

The default is as follows:

```
export ORACLE_HOME=/opt/oracle/product/<version>
```

In this instance, *<version>* is the Oracle database version, 11.1.0, 11.2.0, or 12.1.0.

3. Set the *ORACLE\_SID* environment variable.

The default is as follows:

```
export ORACLE_SID=openview
```

4. Run the SQL\*Plus tool to administrate the database:

```
<ORACLE_HOME>/bin/sqlplus /nolog
```

5. Enter the following commands at the prompt to start the Oracle database:

```
connect / as sysdba  
startup  
exit
```

6. Switch back to the *root* user:

```
exit
```

## Stopping an Oracle Database Manually

To stop an Oracle database manually, follow these steps:

1. Switch to the *oracle* user:

```
su - oracle
```

2. Set the *ORACLE\_HOME* environment variable.

The default is as follows:

```
export ORACLE_HOME=/opt/oracle/product/<version>
```

In this instance, *<version>* is the Oracle database version, 11.1.0, 11.2.0, or 12.1.0.

3. Set the *ORACLE\_SID* environment variable.

The default is as follows:

```
export ORACLE_SID=openview
```

4. Run the SQL\*Plus tool:

```
<ORACLE_HOME>/bin/sqlplus /nolog
```

5. Enter the following to stop the Oracle database:

```
connect / as sysdba  
shutdown  
exit
```

6. Switch back to the *root* user:

```
exit
```



## Starting and Stopping a PostgreSQL Database Manually

Depending on whether you want to start or stop a PostgreSQL database manually, follow the steps described in one of the following sections:

- ["Starting a PostgreSQL Database Manually" below](#)
- ["Stopping a PostgreSQL Database Manually" below](#)

### Starting a PostgreSQL Database Manually

To start a PostgreSQL database manually, follow these steps:

1. Switch to the PostgreSQL operating system user:

```
su - <OS_DBA_user>
```

In this instance, *<OS\_DBA\_user>* is the operating system user that controls database processes and has access to all PostgreSQL binaries and HPOM database directories. The default is *postgres*.

2. Run the *pg\_ctl* tool to start the database:

```
<PostgreSQL_binary_directory>/pg_ctl -D <PostgreSQL_cluster_directory> \  
start -l logfile
```

3. Switch back to the root user by running the following command:

```
exit
```

### Stopping a PostgreSQL Database Manually

To stop a PostgreSQL database manually, follow these steps:

1. Switch to the PostgreSQL operating system user:

```
su - <OS_DBA_user>
```

In this instance, *<OS\_DBA\_user>* is the operating system user that controls database processes and has access to all PostgreSQL binaries and HPOM database directories. The default is *postgres*.

2. Run the *pg\_ctl* tool to stop the database:

```
<PostgreSQL_binary_directory>/pg_ctl -D <PostgreSQL_cluster_directory> \  
stop [ -m [s|f|i] ]
```

You can specify how you want the PostgreSQL database server to be stopped. This means that you can choose among the following modes:

|    |  |
|----|--|
| -m | Shutdown mode.   |
| -s | Smart shutdown mode that waits for all users to disconnect.          |
| -f | Fast shutdown mode that rolls back all transactions and disconnects. |
| -i | Immediate shutdown mode that aborts all sessions immediately.        |

**Note:** If you do not specify any mode, the smart shutdown mode is used.

3. Switch back to the root user by running the following command:

```
exit
```

## Native Language Support in a Database

This section summarizes the Native Language Support (NLS) rules that are used by an installed database.

**Note:** To avoid unnecessary conversions taking place in the database, use the same character set for both the database and the environment of the HPOM user interface and server processes. After you install a database, you can no longer change the character set.

## Oracle Database Character Set

The character set of the database is determined by the `CHARACTER SET` option of the `CREATE DATABASE` command. HPOM uses the `AL32UTF8` character set for all languages.

The NLS parameters are controlled by the Oracle environment variable `NLS_LANG` that has the following format:

```
<language>_<territory>.<character_set>
```

For example, HPOM uses the following `NLS_LANG` setting for the English language:

```
american_america.AL32UTF8
```

By default, HPOM uses the value of `NLS_LANG` set in the environment. If `NLS_LANG` is not set in the environment, HPOM uses the value specified in the following file:

```
/etc/opt/OV/share/conf/ovdbconf
```

If `NLS_LANG` is not present there, HPOM uses the `LANG` value to determine the value of `NLS_LANG`.

HPOM checks the character set of the Oracle database and stores this information as part of its configuration. Oracle provides the `v$nls_parameters` database table that contains the settings for the language and character set parameters.

## PostgreSQL Database Character Set

Independently of whether you have control over the locale and encoding of a particular table or column, the default character set is specified when the database cluster is created. Because HPOM uses the UTF8 character set for the PostgreSQL database, the database is automatically created with this encoding.

## Environment Variables in an Oracle Database

When starting the HPOM process with a database connection, the following steps are taken to determine the database variables:

1. The `ORACLE_HOME` variable is determined.  
If `ORACLE_HOME` is set in the environment, this value is used.  
If not, HPOM uses the value from the following configuration file:  
`/etc/opt/OV/share/conf/ovdbconf`
2. The `ORACLE_SID` variable is determined.  
If `ORACLE_SID` is set in the environment, this value is used.  
If not, HPOM uses the value from the following configuration file:  
`/etc/opt/OV/share/conf/ovdbconf`
3. The `NLS_LANG` variable is determined.  
If `NLS_LANG` is set in the environment, this value is used.  
If not, HPOM uses the value from the following configuration file:  
`/etc/opt/OV/share/conf/ovdbconf`
4. It is determined if the `DATABASE <database>` parameter is set by using the `ovconfchg` command line tool.  
This parameter is used to establish a connection. If set, the `ORACLE_SID` variable is ignored.  
For example, if the `DATABASE ov_net` line is set by using `ovconfchg`, the `opc_op/<password>@ov_net` string is used to connect to the `ov_net` identifier.
5. Connection to the database is established, as described in "[Starting and Stopping a Database Automatically](#)" on page 78.  
If `DATABASE` is not used, the `opc_op/<passwd>` connect string is used.

## Alternative Database Locations

Table 14 shows alternative database installations and describes the location of associated processes.

Table 14: Alternative Database Locations

| Database Scenario              | Location of Processes  |
|--------------------------------|--|
| Local and managed database     | <p>The following processes run on the management server:</p> <ul style="list-style-type: none"><li>• Database processes</li><li>• HP Operations management server processes</li><li>• GUI processes</li></ul> <p>These processes connect to the database server.</p>   |
| Remote or independent database | <p>The following processes run on the management server:</p> <ul style="list-style-type: none"><li>• HP Operations server processes</li><li>• GUI processes</li></ul> <p>The database processes run on the database server that can be on an external system or on the same system as the HP Operations management server.</p> |

## Replacing an HPOM Database

To replace an Oracle database with a PostgreSQL database and vice versa, follow these steps:

1. Download all configuration data by following these steps:
  - a. Create an empty download specification file:

```
mkdir /tmp/cfgdwn  
echo "*" > /tmp/cfgdwn/download.dsf
```
  - b. Download the configuration:

```
/opt/OV/bin/OpC/opccfgdwn /tmp/cfgdwn/download.dsf /tmp/cfgdwn
```
2. *Optional:* Download all messages by following these steps:
  - a. Perform a history download:

```
/opt/OV/bin/OpC/opchistdwn -older 0s -file /tmp/history
```
  - b. Acknowledge all active messages:

```
/opt/OV/bin/OpC/opcack -u <user_for_all_msg_grps> -a -f
```

- c. Perform a second history download:

```
/opt/0V/bin/OpC/opchistdwn -older 0s -file /tmp/active
```

3. Stop HP Operations management server processes by running the following command:

```
/opt/0V/bin/ovc -kill
```

4. Stop the current database.
5. Install new database server binaries.

Depending on the type of database you want to use, see ["Installing an Oracle Database" on page 27](#) or ["Installing a PostgreSQL Database" on page 41](#).

6. *Recommended:* Back up old database directory and configuration files.
7. Remove the old database installation.
8. Create and configure a new database by using one of the following two methods:

- ovoconfigure script

For details, see ["Configuring an Oracle Database" on page 53](#) or ["Configuring a PostgreSQL Database" on page 55](#).

- opcdbsetup tool for the Oracle database or psqlcluster and psqlsetup tools for the PostgreSQL database

For details, see ["Installing an Oracle Database" on page 27](#) or ["Creating and Configuring a PostgreSQL Database Cluster" on page 99](#).

**Caution:** The new database must be created with new database server binaries.

9. Make sure that the new database server is up and running.
10. Upload the configuration data by running the following command:  

```
/opt/0V/bin/OpC/opccfgupld -replace /tmp/cfgdwn
```
11. If you downloaded all the messages, upload them by following these steps:
  - a. Upload the active messages from your download:  

```
/opt/0V/bin/OpC/opchistupl /tmp/active
```
  - b. Unacknowledge the active messages in the history message browser and disown them in the message browser by using the Java GUI.  

For detailed information, see the *HPOM Java GUI Operator's Guide*.
  - c. Upload the history messages:  

```
/opt/0V/bin/OpC/opchistupl /tmp/history
```
12. Restart HP Operations management server processes by running the following command:  

```
/opt/0V/bin/ovc -start
```

# Setting Up HPOM with a Remote/Manual Oracle Database

To set up HPOM with a remote/manual Oracle database, complete the following tasks:

- Task 1: ["Checking System Requirements" below](#)
- Task 2: ["Recognizing Limitations During the HPOM Runtime" below](#)
- Task 3: ["Preparation Steps" on the next page](#)
- Task 4: ["Installing and Configuring HPOM with a Remote/Manual Oracle Database" on page 96](#)

## Checking System Requirements

Before you start setting up HPOM with a remote/manual Oracle database, make sure that the Oracle database server (which can be installed on any platform supported by Oracle) and the Oracle database client (which is installed on the HP Operations management server) are of the same version. You must select the Administrator installation type during the Oracle client installation.

**Caution:** *Oracle Database 11g Release 2 or higher:* Install the 32-bit version of the client because the 64-bit version is not supported at the moment.

Some versions of the client may include the 32-bit `libc1ntsh.so`, `libnnz11.so`, or `libnnz12.so` libraries inside the `lib/` directory instead of the `lib32/` directory. In this case, create symlink named `lib32` that points to the `lib/` directory.

Make sure that the previously created Oracle database for HPOM is used and that it is accessible through Oracle Net Services.

## Recognizing Limitations During the HPOM Runtime

During the HPOM runtime, the following limitations apply:

- Removing the database or dropping the tablespaces by using `opcdbsetup` is not supported. You can remove the database or drop the tablespaces manually.

When removing the database manually, make sure to remove the following files from the HP Operations management server:

- `/etc/opt/OV/share/conf/ovdbconf`
- `/etc/opt/OV/share/conf/OpC/mgmt_sv/.opcdbpwd.sec`

- `/etc/opt/OV/share/conf/OpC/mgmt_sv/.opcdbrem.sec`
- The `mondbfile` policy can run only on the database server. Unassign the `mondbfile` policy from the HP Operations management server policy group and, if an HP Operations agent is running on the database server system, assign the `mondbfile` policy there.
- The `opcaddbf` tool is not supported.

**Note:** For the previously created Oracle database setup, the same limitations apply as for a remote/manual Oracle database setup.

## Preparation Steps

Before installing and configuring HPOM with a remote/manual Oracle database, you must complete the following tasks:

- Task 1: ["Creating and Configuring an HPOM Database on a Database Server" below](#)
- Task 2: ["Configuring Users, Passwords, and User Rights Manually" on page 93](#)
- Task 3: ["Configuring Access to the HPOM Database" on page 95](#)

**Note:** Verify that your system meets the following Oracle requirements:

- Oracle 11gR1 (11.1.0.7), 11gR2 (11.2.0.1–11.2.0.4), or 12cR1 (12.1.0.1 or 12.1.0.2)
- Oracle Net Services 11gR1 (11.1.0.7), 11gR2 (11.2.0.1–11.2.0.4), or 12cR1 (12.1.0.1 or 12.1.0.2)
- SQL\*Plus 11gR1 (11.1.0.7), 11gR2 (11.2.0.1–11.2.0.4), or 12cR1 (12.1.0.1 or 12.1.0.2)

## Creating and Configuring an HPOM Database on a Database Server

To create and configure an HPOM database on the database server, depending on your system, choose one of the following to start the Database Configuration Assistant:

- *Unix and Linux:*

Log on to the database server as the `oracle` user, and then run the following command:

```
$ORACLE_HOME/bin/dbca
```

- *Windows:*

Move to the `<ORACLE_HOME>\bin` directory as the Oracle owner, and then run `dbca.bat`.

The Welcome window opens.

**Caution:** In the process of creating the database by using the Oracle Database Creation Assistant, follow the wizard. Not all steps in the wizard are described in this procedure. In all the steps that are not described, leave default values or make custom selections that suit your needs.

The steps for creating and configuring the HPOM database differ depending on which Oracle database version you use:

- If you use Oracle 11g, see "[Creating and Configuring Oracle Database 11g](#)" below.
- If you use Oracle 12c, see "[Creating and Configuring Oracle Database 12c](#)" on page 91.

## Creating and Configuring Oracle Database 11g

To create and configure Oracle Database 11g, follow these steps:

1. In the Database Templates window, select **Custom Database**, and then click **Next**.

**Note:** During the database creation, a window may pop up with the following error displayed:

```
ORA-29807: Specified operator does not exist
```

In that case, click **Ignore**, and continue with the database configuration.

2. In the Database Identification window, enter the global database name and the Oracle System Identifier (for example, enter `openview` for the global database name). Click **Next**.
3. In the Management Options window, clear the **Configure Enterprise Manager** check box, and then click **Next**.

**Note:** If you leave the default value, the warning message appears informing you that you must either configure a listener before you can proceed or choose to continue without the Database Control configuration. In the latter case, which is recommended, you must clear the **Configure Enterprise Manager** check box.

4. In the Database Components tab of the Database Content window, do the following:
  - a. Clear all the components.
  - b. Click **Standard Database Components**, and then clear all the features.
  - c. Click **OK**.
5. In the Initialization Parameters window, do the following:
  - a. In the Connection Mode tab, select **Dedicated Server Mode**.
  - b. In the Character Sets tab, select **Use Unicode (AL32UTF8)**.

**Note:** For more information about supported character sets and NLS\_LANG values, see the *HPOM Administrator's Reference*.



- c. Click **All Initialization Parameters**, and then set initialization parameters using the recommended values listed in [Table 15](#).

**Caution:** Make sure that `db_block_size` is at least 16384 bytes. Otherwise, the HPOM database creation fails and you must recreate the database from the beginning.

Table 15: Initialization Parameters

| Parameter                                  | Value                            |
|--|----------------------------------|
| <code>db_block_size</code>                 | 16384                            |
| <code>diagnostic_dest</code>               | <code>&lt;ORACLE_BASE&gt;</code> |
| <code>db_files</code>                      | 80                               |
| <code>db_file_multiblock_read_count</code> | 16                               |
| <code>memory_target<sup>a</sup></code>     | 600M                             |
| <code>log_checkpoint_interval</code>       | 99999                            |
| <code>processes</code>                     | 200                              |
| <code>dml_locks</code>                     | 100                              |
| <code>log_buffer</code>                    | 1572864                          |
| <code>max_dump_file_size</code>            | 10240                            |
| <code>open_cursors</code>                  | 1024                             |
| <code>sort_area_size</code>                | 262144                           |
| <code>compatible</code>                    | 11.1.0.0.0                       |
| <code>nls_length_semantics</code>          | BYTE                             |

- 6. In the Database Storage window, create tablespaces and their datafiles using the recommended initial sizes listed in [Table 16](#). Make sure to set `OPC_TEMP` as a default temporary tablespace.

**Caution:** Create the datafiles as autoextend files, so that the datafiles can grow as needed. The autoextend option can be enabled in the Datafiles list under the Storage tab.

<sup>a</sup>The variable that controls the global memory usage of the HPOM instance. The other variable, `memory_max_target`, allows you to dynamically increase the value of `memory_target`. By default, the `memory_max_target` parameter takes the same value as `memory_target`. If you want to adjust the `memory_target` value without restarting the instance, manually specify a greater value for `memory_max_target`.

Table 1 6: Size of Tablespaces and Their Datafiles

| Tablespace Name | Tablespace Type           | Datafile |      |
|-----------------|---------------------------|----------|------|
|                 |                           | Size     | Next |
| SYSTEM          | Locally managed/permanent | 250M     | 1M   |
| SYSAUX          | Locally managed/permanent | 400M     | 1M   |
| TEMP            | Locally managed/temporary | 20M      | 5M   |
| OPC_1           | Locally managed/permanent | 4M       | 6M   |
| OPC_2           | Locally managed/permanent | 5M       | 6M   |
| OPC_3           | Locally managed/permanent | 1M       | 1M   |
| OPC_4           | Locally managed/permanent | 26M      | 2M   |
| OPC_5           | Locally managed/permanent | 1M       | 1M   |
| OPC_6           | Locally managed/permanent | 4M       | 2M   |
| OPC_7           | Locally managed/permanent | 4M       | 2M   |
| OPC_8           | Locally managed/permanent | 4M       | 2M   |
| OPC_9           | Locally managed/permanent | 6M       | 2M   |
| OPC_10          | Locally managed/permanent | 6M       | 6M   |
| OPC_INDEX1      | Locally managed/permanent | 13M      | 1M   |
| OPC_INDEX2      | Locally managed/permanent | 10M      | 1M   |
| OPC_INDEX3      | Locally managed/permanent | 10M      | 1M   |
| OPC_TEMP        | Locally managed/temporary | 4M       | 1M   |
| UNDOTBS1        | Undo                      | 200M     | 5M   |

**Note:** HPOM requires at least three redo logs with the size of 20M each. Having more and bigger redo logs may increase the performance. It is recommended that you create mirrored copies of the redo logs on another disk. For more information, see the *HPOM Administrator's Reference*.

7. In the Creation Options window, select **Create Database**, and then click **Finish**.

**Caution:** When the database is created, define the passwords for the SYSTEM and SYS users.  
Do not forget the passwords you defined. You will need these passwords for HPOM configuration and database administration.

## Creating and Configuring Oracle Database 12c

To create and configure Oracle Database 12c, follow these steps:

1. In the Creation Mode window, select **Advanced Mode**, and then click **Next**.

**Note:** During the database creation, a window may pop up with the following error displayed:  
ORA-29807: Specified operator does not exist  
In that case, click **Ignore**, and continue with the database configuration.

2. In the Database Template window, select **Custom Database**, and then click **Next**.
3. In the Database Identification window, enter the global database name and the SID (for example, enter `openview` for the global database name). Click **Next**.
4. In the Management Options window, clear the **Configure Enterprise Manager (EM) Database Express** check box, and then click **Next**.
5. In the Database Credentials window, select **Use the Same Administrative Password for All Accounts**, and then specify the password for the SYS and SYSTEM users. Click **Next**.

**Caution:** Do not forget the password you specified. You will need it for the HPOM configuration and database administration.

6. In the Network Configuration window, specify the listener name and port. Click **Next**.
7. In the Storage Locations window, do the following:
  - a. Under Database Files, select the **File System** storage type, and then select **Use Database File Locations from Template**.
  - b. Under Recovery Related Files, select the **File System** storage type, and then select **Specify Fast Recovery Area**.
  - c. Click **Next**.
8. In the Database Components tab of the Database Options window, clear all the components, and then click **Next**.
9. In the Initialization Parameters window, do the following:
  - a. In the Memory tab, set the memory size to 600 MB.
  - b. In the Sizing tab, set the block size to 16384 bytes and the number of operating system user processes to 200.

- c. In the Character Sets tab, select **Use Unicode (AL32UTF8)**.

**Note:** For more information about supported character sets and NLS\_LANG values, see the *HPOM Administrator's Reference*.

- d. In the Connection Mode tab, select **Dedicated Server Mode**.
- e. Click **All Initialization Parameters...**, and then click **Show Advanced Parameters**. Set initialization parameters using the recommended values listed in [Table 15](#).

**Caution:** Make sure that `db_block_size` is at least 16384 bytes. Otherwise, the HPOM database creation fails and you must recreate the database from the beginning.

- f. Click **Next**.
10. In the Creation Options window, select the **Create Database** check box, and then click **Customize Storage Locations**.

The Customize Storage window opens. Create tablespaces and their datafiles using the recommended initial sizes listed in [Table 16](#).

Create the datafiles as autoextend files, so that the datafiles can grow as needed. The autoextend option can be enabled in the Datafiles list.

**Caution:** The `OPC_TEMP` tablespace must be set as a default temporary tablespace. However, due to an issue in the current release of Oracle 12c, you cannot do this in the Customize Storage window. For detailed information about how to set the default temporary tablespace, see "[Setting the Default Temporary Tablespace for Oracle 12c](#)" below.

**Note:** HPOM requires at least three redo logs with the size of 20M each. Having more and bigger redo logs may increase the performance.

11. In the Summary window, click **Finish**.

### Setting the Default Temporary Tablespace for Oracle 12c

To set the default temporary tablespace for Oracle 12c, follow these steps:

1. Connect as `sysdba`:
  - a. Depending on your system, choose one of the following:
    - *Unix and Linux:*

Log on as the `oracle` user by running the following command:

```
su - oracle
```
    - *Windows:*

Move to the `<ORACLE_HOME>\bin` directory as the Oracle owner.

- b. Run the following command:

```
sqlplus system as sysdba
```

2. Enter the password for the `system` user. This is the password you set when creating the database.

3. Change the default tablespace by running the following command:

```
alter database default temporary tablespace OPC_TEMP;
```

4. Close `sqlplus` by running the following command:

```
exit
```

## Configuring Users, Passwords, and User Rights Manually

To configure users, passwords, and user rights on the database server manually, follow these steps:

1. Connect as `sysdba` as follows:

- a. Depending on your system, choose one of the following:

- *Unix and Linux:*

Log on as the `oracle` user by running the following command:

```
su - oracle
```

- *Windows:*

Move to the `<ORACLE_HOME>\bin` directory as the Oracle owner.

- b. Run the following command:

```
sqlplus system as sysdba
```

2. Enter the password for the `system` user.

This is the password you set when creating the database.

3. Create the `opc_op` user:

```
create user opc_op identified by <password>  
default tablespace OPC_5 temporary tablespace OPC_TEMP;
```

For example:

```
create user opc_op identified by pwd123  
default tablespace OPC_5 temporary tablespace OPC_TEMP;
```

4. Create the `opc_report` user:

```
create user opc_report identified by <password>  
default tablespace OPC_5 temporary tablespace OPC_TEMP;
```

5. Configure user rights for the created users by running the following commands:

```
create role opc_report_role;
```

```
grant create session to opc_report_role;  
grant opc_report_role to opc_report;
```

```
grant connect,  
    resource,  
    create public synonym,  
    drop public synonym,  
    alter tablespace  
    to opc_op;
```

```
grant create table , create view to opc_op;
```

**Caution:** The `opc_report_role` is required and must be created.

6. *Oracle 12c only:* Remove the default disk space restrictions for the `opc_op` user by running the following command:

```
grant unlimited tablespace to opc_op;
```

7. Prevent the `opc_op` password from expiring by running the following command:

```
SQL> alter profile default limit password_life_time unlimited;
```

8. *Optional:* Configure additional user rights on the database server.

If you want to use the `mondbfile` policy, the `opc_odc` tool, and the HPOM data backup on the management server, type the following:

```
create role opc_monitorer;
```

```
grant select on v_$datafile to opc_monitorer;  
grant select on v_$log to opc_monitorer;  
grant select on v_$logfile to opc_monitorer;  
grant select on v_$database to opc_monitorer;  
grant select on v_$controlfile to opc_monitorer;  
grant select on dba_free_space to opc_monitorer;  
grant select on dba_data_files to opc_monitorer;  
grant select on dba_extents to opc_monitorer;  
grant select on dba_tablespaces to opc_monitorer;  
grant select on dba_tables to opc_monitorer;
```

```
grant select on dba_indexes to opc_op;  
grant select on dba_ind_columns to opc_op;  
grant select on dba_cons_columns to opc_op;  
grant select on dba_constraints to opc_op;  
grant select on v_$parameter to opc_op;  
grant select on v_$sga to opc_op;
```

```
grant opc_monitorer to opc_op;
```

**Caution:** The `mondbfile` policy can run only on the database server. If the HP Operations agent is running on the database server, you can assign the `mondbfile` policy there.

9. Close `sqlplus` by running the following command:  
`exit`

## Configuring Access to the HPOM Database

To configure access to the HPOM database, you must configure Net Services files on the database server either by using Oracle tools or manually. You can choose an Oracle Net alias (HPOM default is `ov_net`) and specify the used Net Services alias when configuring the HP Operations management server.

To create Net Services files manually, follow these steps:

1. Configure Net Services that are needed on the database server.

The `tnsnames.ora` and `listener.ora` Net files are required. Optionally, you can also configure the `tnsnsv.ora` and `sqlnet.ora` files. These files are located in the `$ORACLE_HOME/network/admin` directory. For syntax examples for the `.ora` files, see ["Syntax Examples for the .ora Files" below](#).

**Note:** The example files described in ["Syntax Examples for the .ora Files" below](#) must be thoroughly followed with new lines, spaces, and tabs. In all example files, change the hostname and directory path information according to your system settings.

2. Depending on your system, choose one of the following to start the listener:

- *Unix and Linux systems:*

As the `oracle` user, run the following command:

```
lsnrctl start
```

- *Windows systems:*

Move to the `<ORACLE_HOME>\bin` directory as the Oracle owner, and then run the following command:

```
lsnrctl start
```

3. After creating Net Services files, run the following commands:

```
sqlplus /nolog
connect /as sysdba
alter system set local_listener = ov_net scope = both;
shutdown immediate
startup
```

4. If you are using a firewall on the database system, enable connections to the configured listener port.

## Syntax Examples for the .ora Files

When configuring Net Services, consider the following example files:

### Example Contents of the tnsnames.ora File

```
ov_net =  
  (DESCRIPTION =  
    (ADDRESS_LIST =  
      (ADDRESS =  
        (COMMUNITY = OPENVIEW_COMMUNITY)  
        (PROTOCOL = TCP)  
        (HOST = hrabal)  
        (PORT = 1521)  
      )  
    )  
    (CONNECT_DATA =  
      (SID = openview)  
    )  
  )
```

### Example Contents of the listener.ora File

```
STARTUP_WAIT_TIME_LISTENER = 0  
LOG_DIRECTORY_LISTENER = /opt/oracle/product/11.1.0/network/log  
LISTENER =  
  (ADDRESS_LIST =  
    (ADDRESS = (PROTOCOL = TCP)(HOST = hrabal)(PORT = 1521))  
  )  
SID_LIST_LISTENER =  
  (SID_LIST =  
    (SID_DESC =  
      (SID_NAME = openview)  
      (ORACLE_HOME = /opt/oracle/product/11.1.0)  
    )  
  )  
CONNECT_TIMEOUT_LISTENER = 10  
TRACE_LEVEL_LISTENER = OFF  
LOG_FILE_LISTENER = listener
```

### Example Contents of the tnsnav.ora File

```
LOCAL_COMMUNITIES =  
  (COMMUNITY_LIST =  
    (COMMUNITY = OPENVIEW_COMMUNITY)  
  )
```

### Example Contents of the sqlnet.ora File

```
TRACE_LEVEL_CLIENT = OFF  
TRACE_DIRECTORY_CLIENT = /opt/oracle/product/11.1.0/network/log  
LOG_DIRECTORY_CLIENT = /opt/oracle/product/11.1.0/network/log
```

On Windows systems, the example contents of the sqlnet.ora file also includes the following line:

```
SQLNET.AUTHENTICATION_SERVICES = (NTS)
```

## Installing and Configuring HPOM with a Remote/Manual Oracle Database

To install and configure HPOM with a remote/manual Oracle database, install and configure the HP Operations management server software as described in ["Installing and Configuring the HPOM"](#)



[Software on the Management Server" on page 46](#) with regard to the following steps:

1. When the `ovoinstall` script asks you if you want to continue with the server configuration, leave the `ovoinstall` window open, and then open a new window.
2. In the new window, as the `root` user, install the latest HP Operations management server patch, and then type `y` followed by **ENTER** to continue with the server configuration.

The `ovoconfigure` script asks you if you want to configure the database.

3. Type `y` followed by **ENTER**.

When the `ovoconfigure` script asks you if you want to set up the database manually (local or remote), leave the `ovoconfigure` window open.

4. Open a new window (a terminal to the database server, either local or remote) and, as the `root` user, follow these steps:
  - a. Export `ORACLE_HOME`, `ORACLE_SID`, `LANG`, and `LC_ALL` (for an appropriate `LANG` value, see the *HPOM Administrator's Reference*).

**Note:** Make sure that you use `ORACLE_HOME` of the database client installation, and not `ORACLE_HOME` of the database server.

- b. Copy the following Net files from the Oracle database server to the HP Operations management server:
  - o `$ORACLE_HOME/network/admin/sqlnet.ora`
  - o `$ORACLE_HOME/network/admin/tnsnames.ora`
  - o `$ORACLE_HOME/network/admin/tnsnv.ora`

These files are required on the database server and the HP Operations management server. When you copy the files to the HP Operations management server, check that the directory paths point to the correct locations and modify them if necessary.

**Note:** The `tnsnv.ora` and `sqlnet.ora` files are optional. If you configured these files on the database server, you should also configure them on the HP Operations management server.

If you copy the `sqlnet.ora` file from the Windows system, remove the following line from it on the HP Operations management server:

```
SQLNET.AUTHENTICATION_SERVICES = (NTS)
```

5. Log on as the `oracle` user and verify that you can connect to the database. Run the following commands:

```
su - oracle  
sqlplus opc_op@ov_net
```

6. Return to the `ovoconfigure` window. Type `y` followed by **ENTER** to configure the database.

**Note:** If the database configuration fails, you can perform the database configuration step manually by using `opcdbsetup -p`.

If you rerun `ovoconfigure` after successfully configuring the database with `opcdbsetup -p`, type **n** when the following question appears:

Configure the database?

7. *Optional:* If you configured additional user rights on the database server during the process of configuring users, passwords, and rights manually, you can run `/opt/OV/contrib/OpC/opc_odc` to verify the database setup (the log file is in `/tmp/opc_odc.log`).
8. Configure the Administration UI database connection parameters:
  - a. Add the major Oracle database release number to the `ovodb.DBMajorVersion` property in the `ovoappl.properties`, `opccfg.properties`, and `ovoconfig.properties` files. For example:  
`ovodb.DBMajorVersion=11`  
Make sure that you do not use blank spaces.
  - b. Edit the `ovodb.url` property in the `ovoinstall.properties`, `ovoconfig.properties`, `opccfg.properties`, and `ovoappl.properties` files as follows:  
`ovodb.url=jdbc:oracle:thin:@<db_server_hostname>:<db_port>:<db_name>`  
In this instance, `<db_server_hostname>` is the hostname of the system where the remote database is located, `<db_port>` is the database port, and `<db_name>` is the name of the database.
  - c. Restart the Administration UI by running the following commands:  
`/opt/OV/OMU/adminUI/adminui clean`  
`/opt/OV/OMU/adminUI/adminui start`

## Setting Up HPOM with a Remote/Manual PostgreSQL Database

To set up HPOM with a remote/manual PostgreSQL database, complete the following tasks:

- Task 1: ["Checking System Requirements" on the next page](#)
- Task 2: ["Recognizing Limitations During the HPOM Runtime" on the next page](#)
- Task 3: ["Creating and Configuring a PostgreSQL Database Cluster" on the next page](#)
- Task 4: ["Installing and Configuring HPOM with a Remote/Manual PostgreSQL Database" on page 104](#)

## Checking System Requirements

Before you start setting up HPOM with a remote/manual PostgreSQL database, make sure that the PostgreSQL database server (which can be installed on any platform supported by PostgreSQL) and the PostgreSQL database client (which is installed on the HP Operations management server) are of the same major version (for example, version 9.1.x must be compatible with version 9.1.y).

In a remote database scenario, you must make sure that the previously created PostgreSQL database for HPOM is accessible through the network.

## Recognizing Limitations During the HPOM Runtime

During the HPOM runtime, the following limitations apply:

- For an independent PostgreSQL database setup, removing the database cluster or dropping the database by using `opcdbsetup` is not supported. You can remove the database cluster or drop the database manually.

When removing the database cluster manually, make sure to remove the following files from the HP Operations management server:

- `/etc/opt/OV/share/conf/ovdbconf`
- `/etc/opt/OV/share/conf/OpC/mgmt_sv/.opcdbpwd.sec`
- `/etc/opt/OV/share/conf/OpC/mgmt_sv/.opcdbrem.sec`
- The `mondbfile` policy is not supported with PostgreSQL. The `mondbfile` policy can run only on the database server. Unassign the `mondbfile` policy from the HP Operations management server policy group and, if an HP Operations agent is running on the database server system, assign the `mondbfile` policy there.
- The `opcaddbf` tool is not used with PostgreSQL.

## Creating and Configuring a PostgreSQL Database Cluster

Before installing HPOM, you must create and configure a PostgreSQL database cluster. The PostgreSQL database cluster can be created by using the `psqlcluster` tool or manually. Unless you have a specific reason to create the PostgreSQL database manually, it is strongly recommended that you use the `psqlcluster` tool.

**Note:** Before proceeding, verify that the PostgreSQL version is 9.1, 9.2, 9.3, or 9.4. Open-source versions and commercial offerings from EnterpriseDB are supported.

Depending on whether you want to create and configure a PostgreSQL database cluster by using the `psqlcluster` tool or manually, follow the instructions described in one of the following sections:

- ["Creating and Configuring a PostgreSQL Database Cluster by Using the `psqlcluster` Tool" below](#)
- ["Creating and Configuring a PostgreSQL Database Cluster Manually" on the next page](#)

## Creating and Configuring a PostgreSQL Database Cluster by Using the `psqlcluster` Tool

To create and configure a PostgreSQL database cluster by using the `psqlcluster` tool, on the database server system, run the `psqlcluster` tool that you can find at the following location:

```
/opt/0V/bin/0pC
```

The syntax of the `psqlcluster` tool is as follows:

```
psqlcluster -d <cluster_dir>  
            -b <path_to_psql_binaries>  
            [-o <OS_DBA_user>]  
            [-dt <data_tablespace_dir>]  
            [-it <index_tablespace_dir>]  
            -p <db_port>  
            [-dbu <DB_DBA_user>]  
            [-dbp <DB_DBA_password>]  
            -ar  
            [-u]  
            -h
```

You can use the following options with the `psqlcluster` tool:

|   |   |
|---|---|
| <code>-d &lt;cluster_dir&gt;</code>           | Specifies the PostgreSQL cluster directory where you want the database to be created.   |
| <code>-b &lt;path_to_psql_binaries&gt;</code> | Specifies the path to the directory where the PostgreSQL binaries are stored.   |
| <code>-o &lt;OS_DBA_user&gt;</code>           | Specifies the operating system user that controls database processes and has access to all PostgreSQL binaries and HPOM database directories. |
| <code>-dt &lt;data_tablespace_dir&gt;</code>  | Specifies the directory where the data tablespaces are stored.  |
| <code>-it &lt;index_tablespace_&gt;</code>    | Specifies the directory where the index tablespaces are   |

|   |  |
|---|--|
| <code>dir&gt;</code>                      | stored.  |
| <code>-p &lt;db_port&gt;</code>           | Specifies the port on which the database cluster or server listens.  |
| <code>-dbu &lt;DB_DBA_user&gt;</code>     | Specifies the name of the administrator user inside the database cluster or server.  |
| <code>-dbp &lt;DB_DBA_password&gt;</code> | Specifies the password of the administrator user inside the database cluster or server.  |
| <code>-ar</code>                          | (autorestart) If this option is specified, the database cluster is started automatically at startup.   |
| <code>-u</code>                           | (unattended) If this option is specified, no questions are asked during the PostgreSQL database cluster creation and configuration procedures. |
| <code>-h</code>                           | Shows the usage.   |

## Creating and Configuring a PostgreSQL Database Cluster Manually

To create and configure a PostgreSQL database cluster manually, follow these steps:

1. Verify that the operating system user (`OS_DBA_user`) is already created by the installation program or packages. If the operating system user is not created or you want to use another user, make sure to create it at this point.
2. Create a cluster directory where the main PostgreSQL cluster files will be stored. To do this, run the following command:

```
mkdir -p <cluster_directory>
```

3. Apply proper permissions to the cluster directory by running the following commands:

```
chown <OS_DBA_user> <cluster_directory>
```

```
chmod 700 <cluster_directory>
```

4. Create a file containing the password of the administrator user inside the database cluster or server by running the following command:

```
echo "<DB_DBA_user_password>" > <password_file>
```

5. Create a database cluster by using the `initdb` script provided by PostgreSQL. To do this, run the following commands:

```
su - <OS_DBA_user>
```

```
<PSQL_bin_directory>/initdb -D <cluster_directory> \  
-A md5 -E UTF8 --locale=en_US.utf8 -U <DB_DBA_user> --pwfile=<password_file>
```

By running the `initdb` script, the basic structure of the database cluster is created and initialized.

6. Configure the database cluster by following these steps:

- a. Open the `<cluster_directory>/postgresql.conf` file, and then change the `port`, `listen_addresses`, and `max_locks_per_transaction` parameters according to your needs.

For example:

```
port = 5432  
listen_addresses = '*'  
max_locks_per_transaction = 256 # min 10, default 64
```

**Note:** You can also customize other parameters to adapt the database to the environment needs (for example, `shared_buffers` and `work_mem`). For details, see the PostgreSQL documentation.

- b. Edit the `<cluster_directory>/pg_hba.conf` file to give access to HPOM users.

For example:

```
local all <DB_DBA_user>,opc_op,opc_report md5  
host all <DB_DBA_user>,opc_op,opc_report 0.0.0.0/0 md5  
host all <DB_DBA_user>,opc_op,opc_report ::0/0 md5
```

**Caution:** Make sure that the HP Operations management server can access the PostgreSQL port on the database system by checking the configuration of firewalls, proxies, and Network Address Translation (NAT).

- c. Edit the `.pgpass` file under the `<OS_DBA_user>` home directory to add local access to the administrator user inside the database cluster or the server.

For example:

```
localhost:<Port>:*:<DB_DBA_user>:<DB_DBA_user_password>
```

7. Start the database by running the following commands:

```
su - <OS_DBA_user>  
<PSQL_bin_directory>/pg_ctl -D <cluster_directory> \  
start -l <cluster_directory>/logfile
```

8. Create the data tablespace and index tablespace directories. For each directory, perform as follows:

- a. Create a directory:

```
mkdir -p <directory>
```

- b. Apply proper permissions to the directory:

```
chown <OS_DBA_user> <directory>
chmod 700 <directory>
```

9. Create the tablespaces inside the database. To do this, follow these steps:
  - a. Switch to the operating system user that controls database processes and has access to all PostgreSQL binaries and HPOM database directories:

```
su - <OS_DBA_user>
```

- b. Connect to the database:

```
<PSQL_bin_directory>/psql -p <Port> -U <DB_admin_USER> -h localhost
```

- c. Set the character set to UTF-8:

```
psql> SET client_encoding = 'UTF8';
```

- d. For each tablespace listed in [Table 17](#), run the following command:

```
CREATE TABLESPACE <tablespace_name> OWNER <DB_DBA_user> \
LOCATION E'<directory>;
```

Table 17: Types of Tablespaces

| Tablespace Name | Tablespace Type           |
|-----------------|---------------------------|
| OPENVIEW        | Main data tablespace      |
| OPC_1           | Data tablespace           |
| OPC_2           | Data tablespace           |
| OPC_3           | Data tablespace           |
| OPC_4           | Data tablespace           |
| OPC_5           | Data tablespace           |
| OPC_6           | Data tablespace           |
| OPC_7           | Data tablespace           |
| OPC_8           | Data tablespace           |
| OPC_9           | Data tablespace           |
| OPC_10          | Data tablespace           |
| OPC_INDEX1      | Index tablespace          |
| OPC_INDEX2      | Index tablespace          |
| OPC_INDEX3      | Index tablespace          |
| OPC_TEMP        | Temporary data tablespace |

- e. Quit the PostgreSQL session, and then go back to the terminal window:

```
\q
```

## Installing and Configuring HPOM with a Remote/Manual PostgreSQL Database

To install and configure HPOM with a remote/manual PostgreSQL database, install and configure the HP Operations management server software as described in ["Installing and Configuring the HPOM Software on the Management Server" on page 46](#) with regard to the following steps:

1. When the `ovoinstall` script asks you if you want to continue with the server configuration, leave the `ovoinstall` window open, and then open a new window.
2. In the new window, as the `root` user, install the latest HP Operations management server patch (if needed), and then type `y` followed by **ENTER** to continue with the server configuration.

The `ovoconfigure` script asks you if you want to configure the database.

3. Type `y` followed by **ENTER**.

The following question appears:

```
Will HPOM run on an Oracle instance (n for PostgreSQL)?
```

4. Type `n` followed by **ENTER**.

The `ovoconfigure` script asks you if you want HPOM to manage the PostgreSQL database cluster.

5. Type `n` followed by **ENTER**.

You are asked a series of questions about the database configuration. For detailed information about these questions, see ["Configuring a PostgreSQL Database" on page 55](#).

After you answer all the database-related questions, the summary of all provided answers appears.

6. After you check the data, type `y` followed by **ENTER**.

When the `ovoconfigure` script asks you to perform the remote/manual database configuration, leave the `ovoconfigure` window open.

7. Open a new window (a terminal to the database server, either local or remote) and, as the `root` user, choose how to create a database cluster, manually or automatically.

**Caution:** Before choosing the way of creating the database cluster, make sure that you performed all the steps described in ["Installing PostgreSQL Server Binaries" on page 42](#) and ["Preparing HPOM to Use the PostgreSQL Database" on page 42](#).



- *Creating a database cluster manually:* To create a database cluster manually, follow the instructions described in ["Creating and Configuring a PostgreSQL Database Cluster Manually" on page 101](#).
- *Creating a database cluster automatically:* To create a database cluster automatically, use the `psqlcluster` tool as described in ["Creating and Configuring a PostgreSQL Database Cluster by Using the psqlcluster Tool" on page 100](#).

If you have a database on a local system (that is, a manual PostgreSQL database), the `psqlcluster` tool is already on the system. On the other hand, if you have a database on a remote system (that is, a remote PostgreSQL database), you must obtain the `HP0vOUPSQlConf` package that is appropriate for the architecture of the database system, copy it to the database system, and then install it there according to the procedure indicated for your operating system. You can find the latest version of the `HP0vOUPSQlConf` package that installs a copy of the `psqlcluster` tool in the database system at the following location:

```
/var/opt/OV/packages/PSQL
```

8. Log on as the operating system user (`OS DBA user`), and then verify that you can connect to the database.

Run the following commands:

```
su - postgresql  
<PSQL_bin_directory>/psql -p <Port> -U <DB_admin_USER> -h localhost  
psql > \q
```

9. Return to the `ovoconfigure` window. Type **y** followed by **ENTER** to configure the database.

**Note:** If the database configuration fails, you can perform the database configuration step manually by using `psqlsetup`.

10. *Optional (use only if the database configuration fails):* Set up the PostgreSQL database cluster to be used with HPOM by using the `psqlsetup` tool that you can find at the following location:

```
/opt/OV/bin/OpC
```

The syntax of the `psqlsetup` tool is as follows:

```
psqlsetup -b <path_to_psql_binaries>  
          -l <path_to_psql_libs>  
          -o <OS_DBA_user>  
          -h <hostname>  
          -p <db_port>  
          [-d <database_name>]  
          -dba_user <DB_DBA_user>  
          -dba_pass <DB_DBA_password>  
          [-dbop_pass <DB_opc_op_password>]  
          [-dbrep_pass <DB_opc_report_password>]  
          [-u]
```

[-ni]  
 [-help]

You can use the following options with the `psqlsetup` tool:

|   |  |
|---|--|
| <code>-b &lt;path_to_psql_binaries&gt;</code>           | Specifies the path to the directory where the PostgreSQL binaries are stored.  |
| <code>-l &lt;path_to_psql_libs&gt;</code>               | Specifies the path to the directory where the PostgreSQL client libraries are stored.  |
| <code>-o &lt;OS_DBA_user&gt;</code>                     | Specifies the operating system user that controls database processes and has access to all PostgreSQL binaries and HPOM database directories.  |
| <code>-h &lt;hostname&gt;</code>                        | Specifies the system on which the database cluster or server is installed.   |
| <code>-p &lt;db_port&gt;</code>                         | Specifies the port on which the database cluster or server listens.  |
| <code>-d &lt;database_name&gt;</code>                   | Specifies the name of the HPOM database.   |
| <code>-dba_user &lt;DB_DBA_user&gt;</code>              | Specifies the name of the administrator user inside the database cluster or server.  |
| <code>-dba_pass &lt;DB_DBA_password&gt;</code>          | Specifies the password of the administrator user inside the database cluster or server.  |
| <code>-dbop_pass &lt;DB_opc_op_password&gt;</code>      | Specifies the password for the <code>opc_op</code> database user.  |
| <code>-dbrep_pass &lt;DB_opc_report_password&gt;</code> | Specifies the password for the <code>opc_report</code> database user.  |
| <code>-u</code>   | (unattended) If this option is specified, no questions are asked during the PostgreSQL database cluster creation and configuration procedures. |
| <code>-ni</code>  | (not initialized) If this option is specified, you choose not to initialize the database with the default data.                                |
| <code>-help</code>                                      | Shows the usage.   |

**Note:** If you rerun `ovoconfigure` after successfully configuring the database with `psqlsetup`, make sure that you type **n** when the following question appears:

### Configure the database?

11. *Optional:* If you configured additional user rights on the database server during the process of configuring users, passwords, and rights manually, you can run `/opt/OV/contrib/OpC/opc_odc` to verify the database setup (the log file is in `/tmp/opc_odc.log`).
12. Configure the Administration UI database connection parameters:
  - a. Add the first digit group of the major PostgreSQL version to the `ovodb.DBMajorVersion` property in the `ovoappl.properties`, `opccfg.properties`, and `ovoconfig.properties` files. For example, for PostgreSQL version 9.1, add 9:  

```
ovodb.DBMajorVersion=9
```

Make sure that you do not use blank spaces.
  - b. Edit the `ovodb.url` property in the `ovoinstall.properties`, `ovoconfig.properties`, `opccfg.properties`, and `ovoappl.properties` files as follows:  

```
ovodb.url=jdbc:postgresql://<db_server_hostname>:<db_port>/<db_name>
```

In this instance, `<db_server_hostname>` is the hostname of the system where the remote database is located, `<db_port>` is the database port, and `<db_name>` is the name of the database.
  - c. Restart the Administration UI by running the following commands:  

```
/opt/OV/OMU/adminUI/adminui clean  
/opt/OV/OMU/adminUI/adminui start
```

## Setting Up HPOM in an Oracle Real Application Clusters (RAC) Environment

Oracle Real Application Clusters (RAC) represents a highly available, scalable, and manageable solution for sharing access to a single database among managed nodes in a cluster environment. Even during a system fault on one of the nodes, data can be accessed from any of the remaining nodes. The data on the failed node is recovered automatically without the administrator's intervention.

To set up HPOM in an Oracle RAC environment, complete the following tasks:

- Task 1: ["Checking System Requirements" on the next page](#)
- Task 2: ["Recognizing Limitations During the HPOM Runtime" on the next page](#)
- Task 3: ["Installing Oracle RAC" on page 109](#)
- Task 4: ["Preparation Steps" on page 109](#)
- Task 5: ["Installing and Configuring HPOM in an Oracle RAC Environment" on page 121](#)

## Checking System Requirements

Before you start setting up HPOM in an Oracle RAC environment, make sure that the Oracle database server (which can be installed and used with HPOM on any platform supported by Oracle) and the Oracle database client (which is installed on the HP Operations management server) are of the same version.

For detailed information about Oracle RAC server requirements, see the Oracle RAC documentation at the following URL:

<http://www.oracle.com/us/products/database/options/real-application-clusters/overview/index.html>

Make sure that the previously created Oracle database for HPOM is used and that it is accessible through Oracle Net Services.

**Caution:** HPOM supports Oracle 11g Release 1 RAC (11.1.0.7), Oracle 11g Release 2 RAC (11.2.0.1–11.2.0.4), and Oracle 12c Release 1 RAC (12.1.0.1 and 12.1.0.2).

## Recognizing Limitations During the HPOM Runtime

During the HPOM runtime, the following limitations apply:

- Removing the database or dropping the tablespaces by using `opcdbsetup` is not supported. You can remove the database or drop the tablespaces manually.

When removing the database manually, make sure to remove the following files from the HP Operations management server:

- `/etc/opt/OV/share/conf/ovdbconf`
- `/etc/opt/OV/share/conf/OpC/mgmt_sv/.opcdbpwd.sec`
- `/etc/opt/OV/share/conf/OpC/mgmt_sv/.opcdbrem.sec`
- The `mondbfile` policy is not supported.
- The `opcaddbf` tool is not supported.

**Note:** For the previously created Oracle database setup, the same limitations apply as for a remote/manual Oracle database setup.

## Installing Oracle RAC

The Oracle RAC installation instructions are provided in the Oracle RAC documentation at the following URL:

<http://www.oracle.com/us/products/database/options/real-application-clusters/overview/index.html>

## Preparation Steps

Before installing and configuring HPOM in an Oracle RAC environment, you must complete the following tasks:

- Task 1: "[Creating and Configuring the HPOM Database on Cluster Nodes](#)" below
- Task 2: "[Configuring Users, Passwords, and User Rights Manually](#)" on page 115
- Task 3: "[Configuring Access to the HPOM Database](#)" on page 117

**Note:** Verify that your system meets the following Oracle requirements:

- Oracle 11gR1 (11.1.0.7), 11gR2 (11.2.0.1–11.2.0.4), or 12cR1 (12.1.0.1 or 12.1.0.2)
- Oracle Net Services 11gR1 (11.1.0.7), 11gR2 (11.2.0.1–11.2.0.4), or 12cR1 (12.1.0.1 or 12.1.0.2)
- SQL\*Plus 11gR1 (11.1.0.7), 11gR2 (11.2.0.1–11.2.0.4), or 12cR1 (12.1.0.1 or 12.1.0.2)

## Creating and Configuring the HPOM Database on Cluster Nodes

To create and configure the HPOM database on all cluster nodes<sup>a</sup>, log on to the database server as the `oracle` user, and then start the Database Configuration Assistant by running the following command:

```
$ORACLE_HOME/bin/dbca &
```

The Welcome window opens.

**Note:** In the process of creating the database by using the Oracle Database Creation Assistant, follow the wizard. Not all steps in the wizard are described in this procedure. In all the steps that are not described, leave default values or make custom selections that suit your needs.

The steps for creating and configuring the HPOM database on cluster nodes differ depending on which Oracle database version you use:

<sup>a</sup>Database instances can be created automatically or manually on all cluster nodes.

- If you use Oracle 11g, see "[Creating and Configuring Oracle Database 11g](#)" below.
- If you use Oracle 12c, see "[Creating and Configuring Oracle Database 12c](#)" on page 114.

## Creating and Configuring Oracle Database 11g

To create and configure Oracle Database 11g, follow these steps:

1. In the Welcome window, select **Oracle Real Application Clusters database**, and then click **Next**.

**Note:** The Welcome window is used for creating the Oracle RAC database and it is displayed only if the Oracle home from which it is invoked is on the cluster system. Otherwise, the generic Welcome window opens and only the Oracle single instance database option is available.

2. In the Operations window, select **Create a Database**, and then click **Next**.

**Note:** During the database creation, a window may pop up with the following error displayed:  
ORA-29807: Specified operator does not exist  
In that case, click Ignore, and continue with the database configuration.

3. *If you are using Oracle Database 11g Release 2, skip this step:* In the Node Selection window, select all the cluster nodes on which you want to create the cluster database, and then click **Next**.
4. In the Database Templates window, select **Custom Database**, and then click **Next**.
5. In the Database Identification window, type the global database name (for example, openview) and the Oracle system identifier prefix (for example, GRID) for your cluster database. Click **Next**.
6. In the Management Options window, select **Configure Enterprise Manager** and **Configure Database Control for local management**, and then click **Next**.
7. In the Database Credentials window, define the passwords for the SYSTEM and SYS users, and then click **Next**.

**Caution:** Do not forget the passwords you defined. You will need these passwords for the HPOM configuration and database administration.

8. In the Storage Options window, select **Automatic Storage Management (ASM)**, and then click **Next**.

At this point, you may be asked to provide the ASMSNMP password. If you do not remember this password, you can do one of the following:

- Specify an incorrect password.

When you specify an incorrect password, the error message appears. You can simply ignore this message and continue by clicking **Continue**.

- Change the ASMSNMP password.

To change the ASMSNMP password, connect to the +ASM instance, and then follow these steps:

- i. Switch to the `oracle` user:

```
su - oracle
```

- ii. Set the proper Oracle environment variables for the Oracle Grid infrastructure.

- iii. Run the following commands:

```
sqlplus /nolog
```

```
SQL> conn / as sysasm
```

- iv. Do one of the following:

- Change the password of the existing ASMSNMP user:

```
SQL> alter user asmsnmp identified by <password> ;
```

- Create a new ASMSNMP user:

```
SQL> create user asmsnmp identified by <password> ;
```

```
grant sysdba to asmsnmp;
```

- v. Switch back to the `oracle` user:

```
exit
```

**Note:** If specifying an incorrect password or changing the ASMSNMP password does not solve the issue, check it with your database administrator or see the Oracle product documentation.

9. *If you are using Oracle Database 11g Release 2, skip this step:* Enter the SYS password for the ASM instance, and then click **Next**.
10. In the Database Components tab of the Database Content window, first clear all the components, and then click **Standard Database Components...**  
The Standard Database Components window opens.
11. In the Standard Database Components window, clear all the features, and then click **OK**.  
The Database Content window opens again. Click **Next** to continue.
12. In the Character Sets tab of the Initialization Parameters window, select **Choose from the list of character sets**.

**Note:** For more information on supported character sets and NLS\_LANG values, see the *HPOM Administrator's Reference*.

13. In the Connection Mode tab of the Initialization Parameters window, select **Dedicated Server Mode**.
14. In the Initialization Parameters window, click **All Initialization Parameters**, and then set initialization parameters using the recommended values (see [Table 18](#)).

**Caution:** Make sure that `db_block_size` is at least 16384 bytes. Otherwise, the HPOM database creation fails and you must recreate the database from the beginning.

Table 18: Initialization Parameters

| Parameter                                  | Value         |
|--|---------------|
| <code>db_block_size</code>                 | 16384         |
| <code>diagnostic_dest</code>               | <ORACLE_BASE> |
| <code>db_files</code>                      | 80            |
| <code>db_file_multiblock_read_count</code> | 16            |
| <code>memory_target<sup>a</sup></code>     | 600M          |
| <code>log_checkpoint_interval</code>       | 99999         |
| <code>processes</code>                     | 200           |
| <code>dml_locks</code>                     | 100           |
| <code>log_buffer</code>                    | 1572864       |
| <code>max_dump_file_size</code>            | 10240         |
| <code>open_cursors</code>                  | 1024          |
| <code>sort_area_size</code>                | 262144        |
| <code>compatible</code>                    | 11.1.0.0.0    |
| <code>nls_length_semantics</code>          | BYTE          |

15. In the Database Storage window, create tablespaces and their datafiles using the recommended initial sizes (see [Table 19](#)). Make sure to set `OPC_TEMP` as a default temporary tablespace.

<sup>a</sup>The variable that controls the global memory usage of the HPOM instance. The other variable, `memory_max_target`, allows you to dynamically increase the value of `memory_target`. By default, the `memory_max_target` parameter takes the same value as `memory_target`. If you want to adjust the `memory_target` value without restarting the instance, manually specify a greater value for `memory_max_target`.



Additional tablespaces are required depending on whether you plan to use Undo Tablespace Management or Rollback Segments.

**Caution:** Create the datafiles as autoextend files, so that the datafiles can grow as needed. The autoextend option can be enabled in the Datafiles list under the Storage tab.

Table 19: Size of Tablespaces and Their Datafiles

| Tablespace Name | Tablespace Type           | Datafile |      |
|-----------------|---------------------------|----------|------|
|                 |                           | Size     | Next |
| SYSTEM          | Locally managed/permanent | 300M     | 1M   |
| SYSAUX          | Locally managed/permanent | 400M     | 1M   |
| TEMP            | Locally managed/temporary | 20M      | 5M   |
| OPC_1           | Locally managed/permanent | 7M       | 6M   |
| OPC_2           | Locally managed/permanent | 7M       | 6M   |
| OPC_3           | Locally managed/permanent | 1M       | 1M   |
| OPC_4           | Locally managed/permanent | 26M      | 2M   |
| OPC_5           | Locally managed/permanent | 1M       | 1M   |
| OPC_6           | Locally managed/permanent | 5M       | 2M   |
| OPC_7           | Locally managed/permanent | 4M       | 2M   |
| OPC_8           | Locally managed/permanent | 4M       | 2M   |
| OPC_9           | Locally managed/permanent | 6M       | 2M   |
| OPC_10          | Locally managed/permanent | 7M       | 6M   |
| OPC_INDEX1      | Locally managed/permanent | 13M      | 1M   |
| OPC_INDEX2      | Locally managed/permanent | 10M      | 1M   |
| OPC_INDEX3      | Locally managed/permanent | 10M      | 1M   |
| OPC_TEMP        | Locally managed/temporary | 4M       | 1M   |

**Note:** HPOM requires at least 3 redo logs with a size of 20M each. Having more and bigger redo logs may increase the performance. It is recommended that you create mirrored copies of the redo logs on another disk. For more information, see the *HPOM Administrator's*

*Reference.*

16. In the Creation Options window, select the **Create Database** option, and then click **Finish**.

## Creating and Configuring Oracle Database 12c

To create and configure Oracle Database 12c, follow these steps:

1. In the Database Operation window, select **Create Database**, and then click **Next**.

**Note:** During the database creation, a window may pop up with the following error displayed:

ORA-29807: Specified operator does not exist

In that case, click **Ignore**, and continue with the database configuration.

2. In the Creation Mode window, select **Advanced Mode**, and then click **Next**.
3. In the Database Template window, select the type of database you want to configure and a template for your database:
  - a. From the Database Type drop-down list, select **Oracle Real Application Clusters (RAC) database**.
  - b. From the Configuration Type drop-down list, select **Admin-Managed**.
  - c. Select the **Custom Database** template.
4. In the Database Identification window, enter the global database name and the SID (for example, enter `openview` for the global database name). Click **Next**.
5. In the Database Placement window, select all the nodes on which you want to create the cluster database, and then click **Next**.
6. In the Management Options window, select the **Run Cluster Verification Utility (CVU) Checks Periodically** and **Configure Enterprise Manager (EM) Database Express** check boxes.
7. In the Database Credentials window, select **Use the Same Administrative Password for All Accounts**, and then specify the password for the `SYS` and `SYSTEM` users. Click **Next**.

**Caution:** Do not forget the password you specified. You will need it for the HPOM configuration and database administration.

8. In the Storage Locations window, do the following:
  - a. From the Database files Storage Type drop-down list, select **Automatic Storage Management (ASM)**.
  - b. Select the **Specify Fast Recovery Area** check box.
  - c. Click **Next**.

9. In the Database Components tab of the Database Options window, clear all the components, and then click **Next**.
10. In the Initialization Parameters window, do the following:
  - a. In the Memory tab, set the memory size to 600 MB.
  - b. In the Sizing tab, set the block size to 16384 bytes and the number of operating system user processes to 200.
  - c. In the Character Sets tab, select **Use Unicode (AL32UTF8)**.

**Note:** For more information about supported character sets and NLS\_LANG values, see the *HPOM Administrator's Reference*.

- d. In the Connection Mode tab, select **Dedicated Server Mode**.
- e. Click **All Initialization Parameters...**, and then set initialization parameters using the recommended values listed in [Table 18](#).

**Caution:** Make sure that `db_block_size` is at least 16384 bytes. Otherwise, the HPOM database creation fails and you must recreate the database from the beginning.

11. In the Creation Options window, select **Create Database**, and then click **Customize Storage Locations...**

The Customize Storage window opens. Create tablespaces and their datafiles using the recommended initial sizes listed in [Table 19](#).

**Caution:** The `OPC_TEMP` tablespace must be set as a default temporary tablespace. However, due to an issue in the current release of Oracle 12c, you cannot do this in the Customize Storage window. For detailed information about how to set the default temporary tablespace, see "[Setting the Default Temporary Tablespace for Oracle 12c](#)" on page 92.

**Note:** HPOM requires at least three redo logs with the size of 20M each. Having more and bigger redo logs may increase the performance.

12. In the Summary window, review the selected options, and then click **Finish**.

## Configuring Users, Passwords, and User Rights Manually

To configure users, passwords, and user rights on the database server manually, follow these steps:

1. From one of the nodes, log on as the `oracle` user, and connect as `sysdba`.

Type the following commands:

```
su - oracle  
sqlplus system as sysdba
```

2. Type the password for the system user.

This is the password you set when creating the database.

3. To create the `opc_op` user, run the following command:

```
create user opc_op identified by <password> \  
default tablespace OPC_5 temporary tablespace OPC_TEMP;
```

For example:

```
create user opc_op identified by pwd123 \  
default tablespace OPC_5 temporary tablespace OPC_TEMP;
```

4. To create the `opc_report` user, run the following command:

```
create user opc_report identified by <password> \  
default tablespace OPC_5 temporary tablespace OPC_TEMP;
```

5. To configure user rights for the users you created, run the following commands:

```
create role opc_report_role;
```

```
grant create session to opc_report_role;  
grant opc_report_role to opc_report;
```

```
grant connect,  
    resource,  
    create public synonym,  
    create table,  
    create view,  
    drop public synonym,  
    alter tablespace  
to opc_op;
```

**Caution:** The `opc_report_role` is required and must be created.

6. *Oracle 12c only:* Remove the default disk space restrictions for the `opc_op` user by running the following command:

```
grant unlimited tablespace to opc_op;
```

7. To prevent the `opc_op` password from expiring, type the following:

```
su - oracle  
sqlplus /nolog  
SQL> conn / as sysdba;  
SQL> alter profile default limit password_life_time unlimited;
```

8. *Optional:* Configure additional user rights on the database server.

If you want to use the `opc_odc` tool, type the following:

```
create role opc_monitorer;  
  
grant select on v_$datafile to opc_monitorer;  
grant select on v_$log to opc_monitorer;  
grant select on v_$logfile to opc_monitorer;  
grant select on v_$database to opc_monitorer;
```

```
grant select on v_$controlfile to opc_monitorer;  
grant select on dba_free_space to opc_monitorer;  
grant select on dba_data_files to opc_monitorer;  
grant select on dba_extents to opc_monitorer;  
grant select on dba_tablespaces to opc_monitorer;  
grant select on dba_tables to opc_monitorer;
```

```
grant select on dba_indexes to opc_op;  
grant select on dba_ind_columns to opc_op;  
grant select on dba_cons_columns to opc_op;  
grant select on dba_constraints to opc_op;  
grant select on v_$parameter to opc_op;  
grant select on v_$sga to opc_op;
```

```
grant opc_monitorer to opc_op;
```

9. To close sqlplus, type exit.

## Configuring Access to the HPOM Database

To configure access to the HPOM database, you must configure Net Services files on all cluster nodes of the database server either by using Oracle tools or manually. You can choose an Oracle Net alias (HPOM default is `ov_net`) and specify the used Net Services alias when configuring the HP Operations management server.

To enable the connection from the HP Operations management server to the database instances on all Oracle RAC nodes, specify your configuration preferences in the following file:

```
$ORACLE_HOME/network/admin/tnsnames.ora
```

**Figure 2: Example of RAC Configuration**

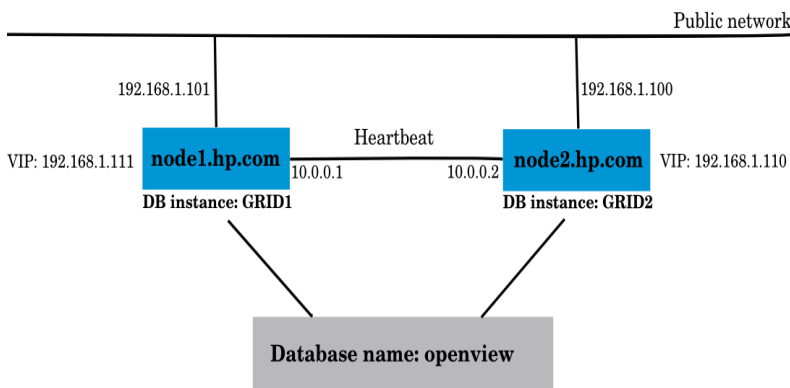


Figure 2 shows the example of the Oracle RAC configuration for the following managed nodes:

- node1.hp.com  
With IP address 192.168.1.101, virtual node name node1-vip, and configured database instance GRID1

- node2.hp.com

With IP address 192.168.1.100, virtual node name node2-vip, and configured database instance GRID2

During the Oracle RAC configuration, the database name is specified (for example, openview). The database consists of both database instances, GRID1 and GRID2.

**Caution:** Make sure that the ORACLE\_SID variable is always properly set. In the shown example, the ORACLE\_SID variable is GRID1 on the first node and GRID2 on the second node.

The HP Operations management server uses the ov\_net alias to connect to the HPOM database (service name openview in [Figure 2](#)). The Oracle RAC server handles the database connections as specified in the tnsnames.ora file by using load balancing and failover. For detailed information, see the Oracle RAC documentation.

### Creating Net Services Manually

To create Net Services files manually, follow these steps:

1. Configure Net Services that are needed on all Oracle RAC cluster nodes.

The tnsnames.ora and listener.ora files are required. Optionally, you can also configure the tnsnav.ora and sqlnet.ora files. These files are located in the \$ORACLE\_HOME/network/admin directory. You can find syntax examples for the .ora files in "[Syntax Examples for the .ora Files](#)" on the next page.

**Note:** The example files described in "[Syntax Examples for the .ora Files](#)" on the next page must be thoroughly followed with new lines, spaces, and tabs. In all example files, change hostnames, IPs, and directory paths according to your system settings.

2. Start the listener as the oracle user on each node by typing the following:

```
su - oracle  
lsnrctl start <listener_name>
```

**Note:** With some installations, it is possible that Oracle already created its own listener files. To stop the listeners, follow these steps:

- a. Log on as root.
- b. Export the ORACLE\_HOME, ORACLE\_BASE, and ORACLE\_SID variables, and then add \$ORACLE\_HOME/bin to PATH.
- c. Stop the listener by running the following command:  

```
lsnrctl stop <listener_name>
```
- d. Log on as the oracle user and start the correct listener.

## Syntax Examples for the .ora Files

When configuring Net Services, consider the following example files:

### Example Contents of the tnsnames.ora File

```
OPENVIEW =
  (DESCRIPTION =
    (ADDRESS = (PROTOCOL = TCP)(HOST = node1-vip)(PORT = 1521))
    (ADDRESS = (PROTOCOL = TCP)(HOST = node2-vip)(PORT = 1521))
    (LOAD_BALANCE = yes)
    (CONNECT_DATA =
      (SERVER = DEDICATED)
      (SERVICE_NAME = openview)
    )
  )
)

ov_net =
  (DESCRIPTION =
    (ADDRESS = (PROTOCOL = TCP)(HOST = node1-vip)(PORT = 1521))
    (ADDRESS = (PROTOCOL = TCP)(HOST = node2-vip)(PORT = 1521))
    (LOAD_BALANCE = yes)
    (CONNECT_DATA =
      (SERVER = DEDICATED)
      (SERVICE_NAME = openview)
      (FAILOVER_MODE =
        (TYPE = SELECT)
        (METHOD = BASIC)
        (RETRIES = 180)
        (DELAY = 5)
      )
    )
  )
)

GRID1 =
  (DESCRIPTION =
    (ADDRESS = (PROTOCOL = TCP)(HOST = node1-vip)(PORT = 1521))
    (CONNECT_DATA =
      (SERVER = DEDICATED)
      (SERVICE_NAME = openview)
      (INSTANCE_NAME = GRID1)
    )
  )
)

GRID2 =
  (DESCRIPTION =
    (ADDRESS = (PROTOCOL = TCP)(HOST = node2-vip)(PORT = 1521))
    (CONNECT_DATA =
      (SERVER = DEDICATED)
      (SERVICE_NAME = openview)
      (INSTANCE_NAME = GRID2)
    )
  )
)

LISTENERS_OPENVIEW =
  (ADDRESS_LIST =
    (ADDRESS = (PROTOCOL = TCP)(HOST = node1-vip)(PORT = 1521))
    (ADDRESS = (PROTOCOL = TCP)(HOST = node2-vip)(PORT = 1521))
  )
)
```

```
)  
  
NODE_1 =  
  (DESCRIPTION =  
    (ADDRESS = (PROTOCOL = TCP)(HOST = node1-vip)(PORT = 1521))  
    (CONNECT_DATA =  
      (SID = GRID1)  
    )  
  )  
)  
  
NODE_2 =  
  (DESCRIPTION =  
    (ADDRESS = (PROTOCOL = TCP)(HOST = node2-vip)(PORT = 1521))  
    (CONNECT_DATA =  
      (SID = GRID2)  
    )  
  )  
)
```

### Example Contents of the listener.ora File on node1.hp.com

```
LISTENER_NODE1 =  
  (DESCRIPTION_LIST =  
    (DESCRIPTION =  
      (ADDRESS_LIST =  
        (ADDRESS =  
          (PROTOCOL = TCP) (HOST = node1-vip) (PORT = 1521) (IP = FIRST)  
        )  
      )  
    )  
    (ADDRESS_LIST =  
      (ADDRESS =  
        (PROTOCOL = TCP) (HOST = node1) (PORT = 1521) (IP = FIRST)  
      )  
    )  
    (ADDRESS_LIST =  
      (ADDRESS =  
        (PROTOCOL = IPC) (KEY = EXTPROC))  
      )  
    )  
  )  
  
CONNECT_TIMEOUT_LISTENER_NODE1 = 10  
LOG_DIRECTORY_LISTENER_NODE1 = /opt/oracle/product/11.1.0/network/log  
LOG_FILE_LISTENER_NODE1 = LISTENER_NODE1  
  
SID_LIST_LISTENER_NODE1 =  
  (SID_LIST =  
    (SID_DESC =  
      (SID_NAME=GRID1)  
      (GLOBAL_DBNAME = openview)  
      (ORACLE_HOME=/opt/oracle/product/11.1.0/)  
    )  
  )  
  
TRACE_LEVEL_LISTENER_NODE1 = OFF
```

### Example Contents of the tnsnav.ora File

```
LOCAL_COMMUNITIES =  
  (COMMUNITY_LIST =  
    (COMMUNITY = OPENVIEW_COMMUNITY)  
  )
```



### Example Contents of the sqlnet.ora File

```
TRACE_LEVEL_CLIENT = OFF  
TRACE_DIRECTORY_CLIENT = /opt/oracle/product/11.1.0/network/log  
LOG_DIRECTORY_CLIENT = /opt/oracle/product/11.1.0/network/log
```

## Installing and Configuring HPOM in an Oracle RAC Environment

To set up HPOM in an Oracle RAC environment, install the HP Operations management server software either as described in ["Installing and Configuring the HPOM Software on the Management Server" on page 46](#) or in the procedure for installing HPOM in a cluster environment, with regard to the following steps:

1. When the `ovoinstall` script asks you if you want to continue with the server configuration, leave the `ovoinstall` window open, and then open a new window.
2. In the new window, as the `root` user, install the latest HP Operations management server patch, and then type `y` followed by **ENTER** to continue with the server configuration.

**Caution:** If you install HPOM in a cluster environment, install the latest HP Operations management server patch for all cluster nodes.

The `ovoconfigure` script asks you if you want to configure the database.

3. Type `y` followed by **ENTER**.

When the `ovoconfigure` script asks you if you want to set up the database manually, leave the `ovoconfigure` window open.

4. Open a new window, and, as the `root` user, follow these steps:

**Caution:** If you are installing HPOM in a cluster environment, perform these steps only for the first cluster node.

- a. Export `ORACLE_HOME`, `ORACLE_SID`, and `LANG` (for an appropriate `LANG` value, see the *HPOM Administrator's Reference*).
- b. Copy the following Net files from the Oracle database server to the HP Operations management server:
  - o `$ORACLE_HOME/network/admin/sqlnet.ora`
  - o `$ORACLE_HOME/network/admin/tnsnames.ora`
  - o `$ORACLE_HOME/network/admin/tnsnv.ora`

These files are required on the database server and the HP Operations management server. When you copy the files to the HP Operations management server, check that the directory paths point to the correct locations, and modify them if necessary.

**Note:** The `tnsnsv.ora` and `sqlnet.ora` files are optional. If you configured these files on the RAC cluster, you must also configure them on the HP Operations management server.

- c. If you are installing HPOM in a cluster environment, export the `OPC_HA` and `OPC_MGMT_SERVER` variables by running the following commands:

```
/opt/OV/bin/ovconfchg -ovrg server -ns opc -set OPC_HA TRUE
/opt/OV/bin/ovconfchg -ovrg server -ns opc -set \
OPC_MGMT_SERVER <valid_virtual_host>
```

In this instance, `<valid_virtual_host>` is the long hostname of the virtual host that was previously selected during the installation procedure.

5. Return to the `ovoconfigure` window. Type **y** followed by **ENTER** to configure the database.

**Note:** The database configuration step can be done manually by using `opcdbsetup -p`.

6. *Optional:* If you configured additional user rights on the database server during the process of configuring users, passwords, and rights manually, you can run `/opt/OV/contrib/OpC/opc_odc` to verify the database setup (the log file is in `/tmp/opc_odc.log`).

## Configuring the Administration UI for Oracle RAC

To configure the Administration UI for Oracle RAC, you must modify the Administration UI configuration files after the installation is complete. Otherwise, you will not be able to list or modify HPOM objects. In addition, a connection error message will appear.

### Example of Oracle RAC Configuration:

Assume that your Oracle RAC environment consists of the servers with physical hostnames `astrid14` and `astrid15`, and virtual hostnames `astrid14-vip` and `astrid15-vip`. The port is `1521` and the SID is `openview`.

In this case, the following configuration files must be modified:

```
/opt/OV/OMU/adminUI/conf/opccfg.properties
/opt/OV/OMU/adminUI/conf/ovoappl.properties
/opt/OV/OMU/adminUI/conf/ovoconfig.properties
/opt/OV/OMU/adminUI/conf/ovoinstall.properties
```

Each of these configuration files contains a JDBC connection string that looks as follows:

```
ovodb.url=jdbc:oracle:thin:@astrid15:1521:openview
```

Use the virtual hostnames in the process of modifying the configuration files. In addition, use the proper port and SID data when required.

To configure Oracle RAC, follow these steps:

1. Modify the configuration files so that each of them contains the correct Oracle RAC JDBC connection string. To do this, choose one of the following ways:

- By replacing the default JDBC connection string:

In this example, the string in each configuration file should look as follows:

```
ovodb.url=jdbc:oracle:thin:@(DESCRIPTION=(FAILOVER=ON)(ADDRESS_LIST=(LOAD_
BALANCE=ON)(ADDRESS=(PROTOCOL=TCP)(HOST=astrid14-vip)(PORT=1521))(ADDRESS=
(PROTOCOL=TCP)(HOST=astrid15-vip)(PORT=1521)))(CONNECT_DATA=(SERVICE_
NAME=openview)))
```

- *Oracle 11g Release 2 or higher:* By using the SCAN listener:

When using a SCAN listener, you provide only a hostname. The Oracle client and the name service are responsible for modifying the configuration files.

For example, type the following:

```
ovodb.url=jdbc:oracle:thin:@(DESCRIPTION=(ADDRESS=(PROTOCOL=TCP)(HOST=omlrac-
scan.hp.com)(PORT=1521))(CONNECT_DATA=(SERVICE_NAME=openview)
(SERVER=DEDICATED)))
```

2. After the JDBC connection string is modified, add the following line to the `/opt/OV/OMU/adminUI/conf/servicemix/wrapper.conf` file:

```
wrapper.java.additional.17=-Duser.timezone=<time_zone>
```

For example, `<time_zone>` can be UTC.

3. Make sure that the value of the `ovodb.DBMajorVersion` variable in the `opccfg.properties`, `ovoappl.properties`, and `ovoconfig.properties` files is set to the database major version (that is, 11 or 12).
4. Restart the Administration UI by running the following commands:

```
/opt/OV/OMU/adminUI/adminui stop  
/opt/OV/OMU/adminUI/adminui clean  
/opt/OV/OMU/adminUI/adminui start
```

# Chapter 5: Directory Structure on the Management Server

## In This Chapter

This chapter provides file trees showing the hierarchy of HPOM directories on the management server.

## HPOM File Tree on the Management Server

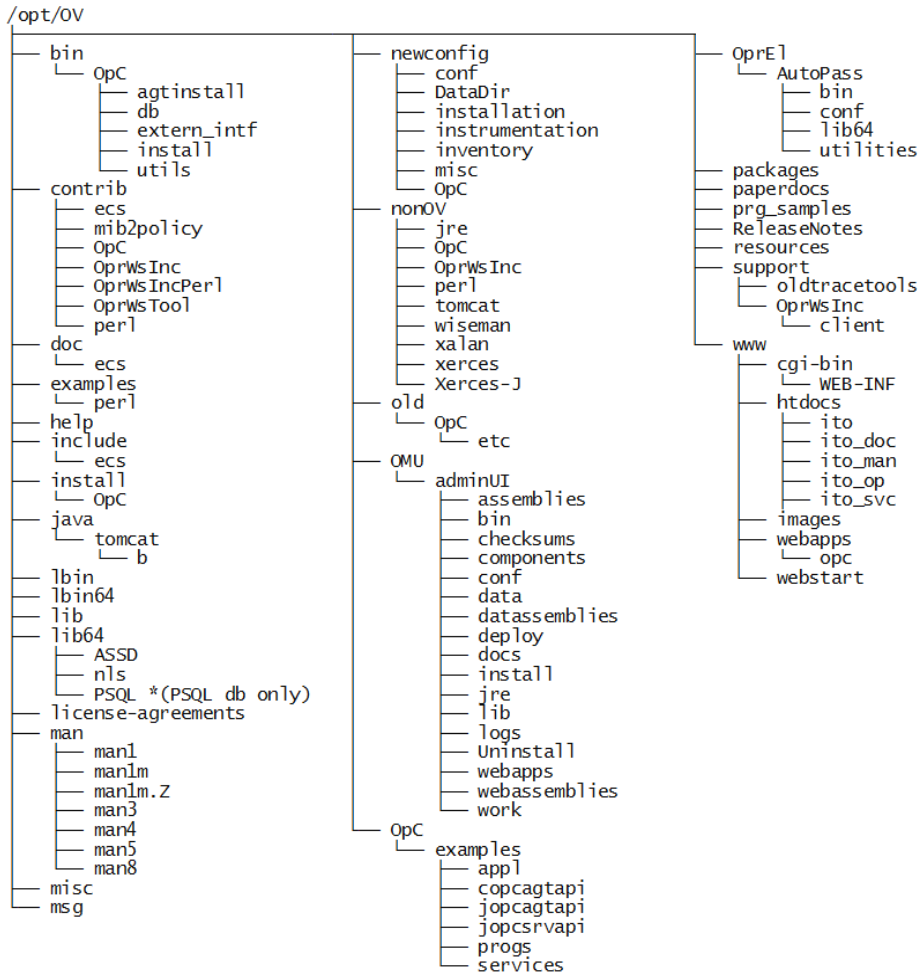
The layout of the HPOM file structure conforms to the standard structure of the UNIX system.

The major HPOM directories contain the following:

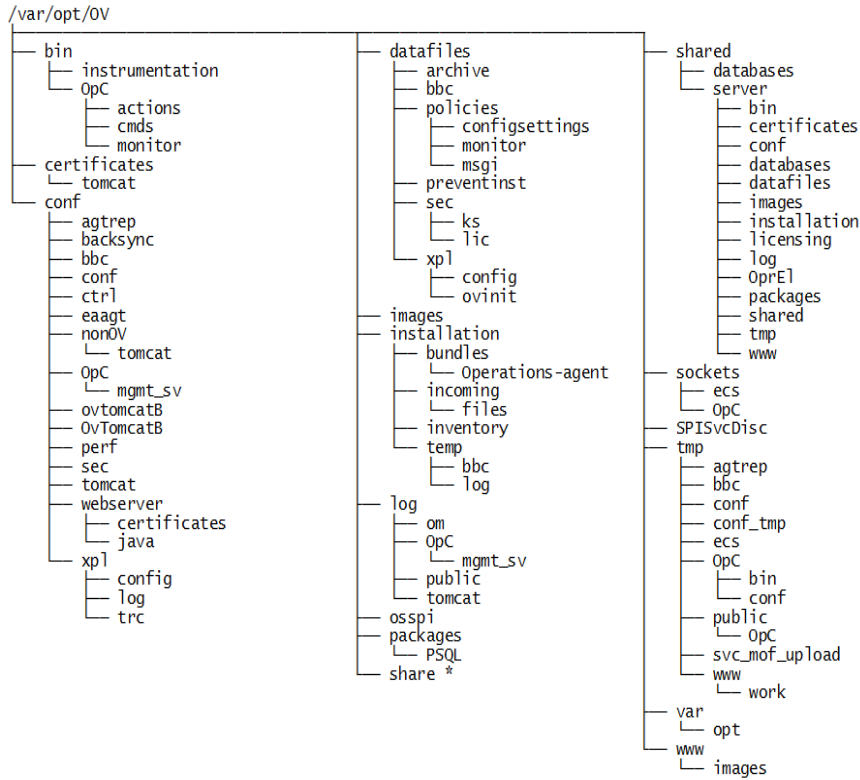
|             |                    |
|-------------|--------------------|
| /opt/OV     | All HPOM binaries  |
| /etc/opt/OV | Configuration data |
| /var/opt/OV | Run-time data      |

**Note:** The file tree can include additional subdirectories if HP Operations agent software or other HP Operations software is installed.

**Figure 3: File Tree on the Management Server (/opt/OV Branch)**

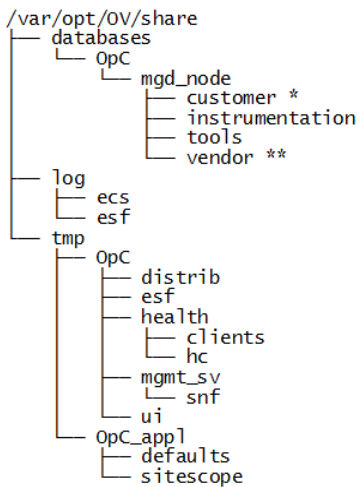


**Figure 4: File Tree on the Management Server (/var/opt/OV Branch)**

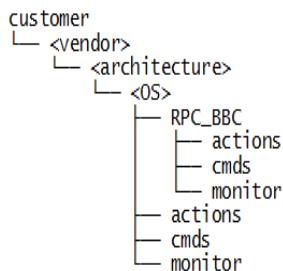


\* For the directory subtree of the /var/opt/OV/share directory, see [Figure 5](#).

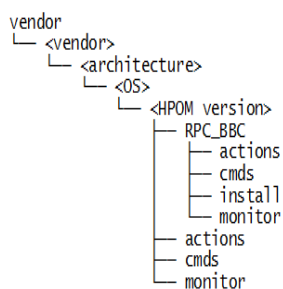
**Figure 5: File Tree on the Management Server (/var/opt/OV/share Branch)**



\* Includes a series of customer-specific directory subtrees with the following structure:



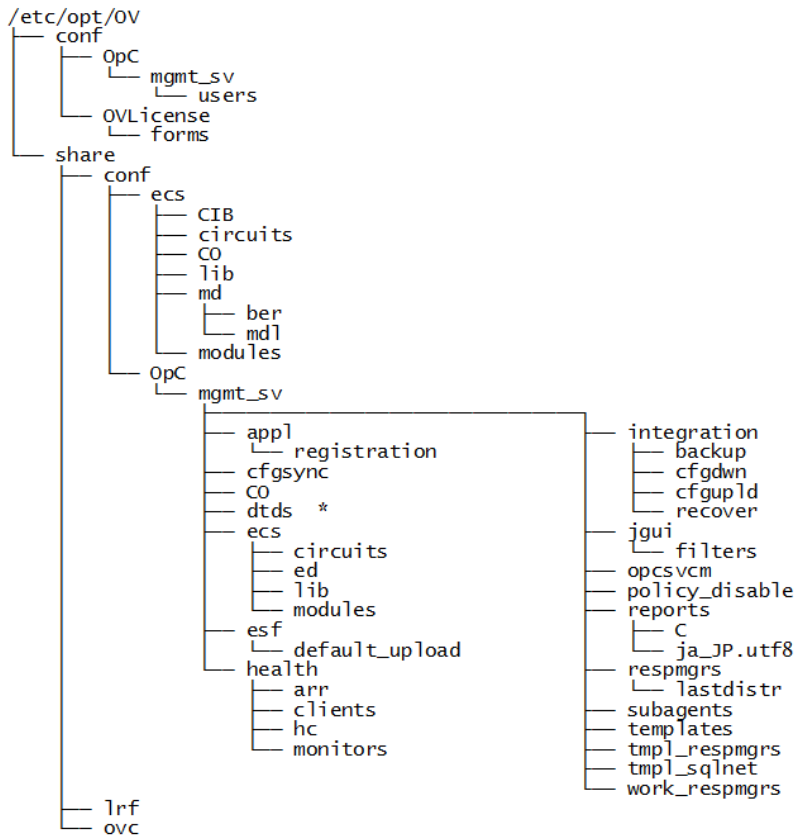
\*\* Includes a series of vendor-specific directory subtrees with the following structure:



<HPOM version> is the version of HPOM that supports a particular agent platform. HPOM can manage several different HPOM versions for each agent platform.

The customer subtree is similar to the vendor subtree, without the HPOM version. You can integrate your additional scripts, including individual scripts and binaries in the monitor, cmds, and actions subdirectories. These files are automatically distributed to the managed node by HPOM.

**Figure 6: File Tree on the Management Server (/etc/opt/OV Branch)**



## System Resources Adapted by HPOM

HPOM makes changes in the following system resource files:

- /etc/passwd  
Contains the entry for the default HPOM operator.
- /etc/group  
Contains the entry for the default HPOM operator.
- /etc/services  
Adds the ito-e-gui service for the Java GUI.
- /etc/inetd.conf  
Starts the /opt/OV/bin/OpC/opcuwww process when requested.



# Chapter 6: Software Administration on the Management Server

## In This Chapter

This chapter describes how to do the following:

- Deinstall HPOM from the management server.
- Deinstall the Java GUI.
- Reinstall HPOM on the management server.
- Reinstall the Administration UI.

## Deinstalling HPOM

To deinstall HPOM, follow these steps:

1. Log on to the management server as the root user.
2. Stop all managed node services by running the following command:  

```
/opt/OV/bin/OpC/opcragt -stop -all
```
3. *Optional:* Deinstall the HPOM software from all managed nodes, excluding the management server, by running the `inst.sh` script:

```
/opt/OV/bin/OpC/agtinstall/inst.sh -r
```

4. Check if any Java GUIs are connected to the management server by running the following command:

```
/opt/OV/contrib/OpC/listguis
```

If there are Java GUIs connected to the management server, stop them by selecting **File > Exit**. Alternatively, you can stop the Java GUIs by using the `kill` command.

**Caution:** Before removing server packages, remove all server patches and applications that have a dependency on server packages. Otherwise, the removal of the HP Operations management server might fail.

5. Start the HPOM deinstallation by running the `ovoremove` script:

```
/opt/OV/bin/OpC/install/ovoremove
```

**Note:** For the information about the additional steps that you might need to perform, see the latest edition of the *HPOM Software Release Notes*.

The `ovoremove` script checks the current directory and if there are any opened Java GUIs.

The following text is displayed:

```
Welcome to the HP Operations Manager for UNIX removal
```

6. Press **ENTER** to verify that you want the removal procedure to start.

**Note:** The whole removal procedure is written in the following log files that you can view at any time during the removal procedure:

- `/var/opt/OV/log/OpC/mgmt_sv/installation.log`
- `/var/opt/OV/log/OpC/mgmt_sv/installation.log.error`
- `/var/opt/OV/log/OpC/mgmt_sv/installation.log.verbose`

The `ovoremove` script detects if the management server runs as a HARG and removes the Administration UI. It also detects which server add-on packages are installed, and then it asks you if you want to continue with the removal of server add-ons.

7. Press **ENTER** to accept `y` as the default answer.

The `ovoremove` script continues with the following:

- Server add-on packages removal
- Event Storm Filter component removal
- Health Check component removal
- Web server configuration removal
- Java GUI configuration removal
- Deintegration from the start-stop sequence
- Database removal
- Other server configuration removal

**Caution:** If the `opc_op` user and the `opcgrp` group are still present on the system after the HPOM deinstallation, you can remove them manually.

8. Press **ENTER** to continue.

The `ovoremove` script detects the installed software and informs you about the packages and components that will be removed:

- ECS Composer packages
- Localization packages
- Server packages
- Core components

9. Press **ENTER** to continue with the software removal.

After the software removal is done, the `ovoremove` script asks you if you want to continue with the local agent removal.

10. Press **ENTER** to accept `y` as the default answer and remove the local agent.

When the local agent is removed, the HPOM deinstallation procedure is finished.

**Note:** Do not remove the `/opt/OV`, `/etc/opt/OV`, and `/var/opt/OV` directories unless all HP products are removed.

If the `/var/opt/midas` directory (containing the configuration file created when the Administration UI is installed) is still present on the system after the HPOM deinstallation, it is recommended to remove it by running the following command:

```
rm -r /var/opt/midas
```

To deinstall the database, see the documentation supplied by the database vendor.

## Deinstalling the Java GUI

If you no longer need the Java GUI, you can easily deinstall it.

## Deinstalling the Java GUI from a Windows Client

To deinstall the Java GUI from a Windows client, follow these steps:

1. Close all running GUIs on the client.
2. Select **Start > Control Panel > Programs and Features**.

The Programs and Features window opens.

3. In the Programs and Features window, select **HP Operations Manager Java Console**, and then click **Uninstall**.

## Deinstalling the Java GUI from an HP-UX 11i Client

To deinstall the Java GUI from an HP-UX 11i client, follow these steps:

1. Close all running GUIs.
2. Deinstall the Java GUI by using the `swremove` utility. To do so, type the following:

```
/usr/sbin/swremove HPOvOUsServer.HPOVOUWWWGUI
```

Make sure that you also remove the language-specific (or locale-specific) package:

- *English*  
`swremove HPOvOUsServer.HPOVOUWWWENG`
- *Spanish*  
`swremove HPOvOUsServer.HPOVOUWWWSPA`
- *Japanese*  
`swremove HPOvOUsServer.HPOVOUWWWJPN`
- *Korean*  
`swremove HPOvOUsServer.HPOVOUWWWKOR`
- *Simplified Chinese*  
`swremove HPOvOUsServer.HPOVOUWWWSCH`

## Deinstalling the Java GUI from Other UNIX-based Systems

To deinstall the Java GUI from other UNIX-based systems, follow these steps:

1. Close all running GUIs on the client.
2. Remove the `/opt/OV/www/htdocs/ito_op/` directory and its contents.

## Reinstalling HPOM

To reinstall HPOM, follow these steps:

1. Make a copy of old management server certificates by running the following command:

```
/opt/OV/bin/OpC/opcsvcertbackup -backup \  
-passwd <passwd> -file <old_certs>
```

In this instance, `<passwd>` is the user password and `<old_certs>` is the file with the old management server certificates.

If you omit the `-file` option, a `.tar` archive file is created at the following default location:  
`/tmp/opcsvcertbackup.<date_time>.tar`

2. Make a copy of the old management server `OvCoreId` by running the following command:

```
/opt/OV/bin/ovcoreid -ovrg server > /tmp/mgmtsv_coreid
```

**Note:** Make sure that the old management server `OvCoreId` and certificates are reused after the HP Operations management server installation. If they are not reused, managed nodes cannot communicate with the management server.

3. Download the configuration data by following these steps:

- a. Create an empty download specification file:

```
mkdir /tmp/cfgdwn  
echo "*" ;" > /tmp/cfgdwn/download.dsf
```

- b. Download the configuration:

```
/opt/OV/bin/OpC/opccfgdwn /tmp/cfgdwn/download.dsf /tmp/cfgdwn
```

4. *Optional:* Download all messages by following these steps:

- a. Perform a history download:

```
/opt/OV/bin/OpC/opchistdwn -older 0s -file /tmp/history
```

- b. Acknowledge all active messages:

```
/opt/OV/bin/OpC/opcack -u <user_for_all_msg_grps> -a -f
```

- c. Perform a second history download:

```
/opt/OV/bin/OpC/opchistdwn -older 0s -file /tmp/active
```

5. Deinstall the current HPOM software by using the `ovoremove` script:

```
/opt/OV/bin/OpC/install/ovoremove
```

**Note:** After you run the `ovoremove` script, make sure that you check the latest edition of the *HPOM Software Release Notes* for the information about the additional steps that you might need to perform.

6. Install HPOM as described in "[Installing and Configuring the HPOM Software on the Management Server](#)" on page 46.

7. Update the `OvCoreId` and certificates on the new management server by following these steps:

- a. Stop all HPOM processes:

```
/opt/OV/bin/ovc -kill
```

- b. Install the certificate backup from the old HP Operations management server:

```
/opt/OV/bin/OpC/opcsvcertbackup -restore \  
-passwd <passwd> -file <old_certs> -force
```

In this instance, *<passwd>* is the user password and *<old\_certs>* is the file with the old management server certificates.

**Caution:** Do not forget to use the `-force` option when installing the certificate backup from the old HP Operations management server.

- c. Update the local agent `OvCoreId` in the database:

```
/opt/OV/bin/OpC/Utils/opcnode -chg_id node_name=<Local_agent_hostname> \  
id=`cat /tmp/mgmtsv_coreid`
```

To verify that the `OvCoreId` was correctly updated in the database, run the following command:

```
/opt/OV/bin/OpC/Utils/opcnode -list_id node_list=<Local_agent_hostname>
```

8. Upload the configuration data by running the following command:

```
/opt/OV/bin/OpC/opccfgupld -replace /tmp/cfgdwn
```

9. *Only if you downloaded all the messages:* Upload the messages by following these steps:

- a. Upload the active messages from your download:

```
/opt/OV/bin/OpC/opchistupl /tmp/active
```

- b. Unacknowledge the active messages in the history message browser and disown them in the message browser by using the Java GUI.

For detailed information, see the *HPOM Java GUI Operator's Guide*.

- c. Upload the history messages:

```
/opt/OV/bin/OpC/opchistupl /tmp/history
```

10. Restart the HPOM processes:

```
/opt/OV/bin/ovc -start
```

11. Check agent connectivity by running the following command:

```
/opt/OV/bin/OpC/opcragt <remote_agent_hostname>
```

## Reinitializing the HPOM Database and Configuration

If required, you can reinitialize the HPOM database and configuration on the management server after reinstalling HPOM.

To reinitialize the HPOM database and configuration, follow these steps:

1. If required, deinstall HPOM from all managed nodes as described in the *HPOM Administrator's Reference*.

**Caution:** After you reinitialize the HPOM database, all the node configuration is lost. You must reconfigure the nodes.

2. *Only if you use the Oracle database with HPOM:* As the root user, export the Oracle variables as follows:

```
export ORACLE_HOME=/opt/oracle/product/<version>  
export ORACLE_BASE=/opt/oracle
```

3. *Only if HPOM was deinstalled:* Reinstall HPOM as described in ["Reinstalling HPOM" on page 132](#).

4. Stop HP Operations management server and agent processes by running the following commands:

```
/opt/OV/bin/OpC/opcsv -stop  
/opt/OV/bin/ovc -stop AGENT
```

5. Clean the database, including the configuration for operators and nodes, as well as all active and history messages. To do so, run the following commands:

```
su - root  
/opt/OV/bin/OpC/opcdbinit -c [-v]  
exit
```

The `opcdbinit` command uses the following modes:

|    |  |
|----|--|
| -c | <i>Clean mode.</i> Cleans up tables and loads the default configuration. |
| -v | <i>Verbose mode.</i> Used to show the detailed processing progress.      |

6. Restart the HP Operations management server and agent processes by running the following commands:

```
/opt/OV/bin/OpC/opcsv -start  
/opt/OV/bin/ovc -start AGENT
```

## Reinstalling the Administration UI

To reinstall the Administration UI, follow these steps:

1. Deinstall the Administration UI by running the following command:

```
/opt/OV/OMU/adminUI/Uninstall/uninstall.bin
```

2. *Recommended:* Clear the Administration UI directory to make sure there are no remains that may affect the new installation. To do so, run the following command:

```
rm -rf /opt/OV/OMU/adminUI/*
```

3. Edit the `/opt/OV/bin/OpC/install/checkpoints.conf` file by removing the following line from

it:

```
CONFIGURE .INSTALL_ADMINUI: DONE
```

**Caution:** If you do not edit the checkpoints.conf file, the ovoconfigure script skips the Administration UI installation.

4. Install the Administration UI by running the following command:

```
/opt/OV/bin/OpC/install/ovoconfigure -installAdminUI \  
-adminUIdir <path_to_install_bin>
```

For example:

```
/opt/OV/bin/OpC/install/ovoconfigure -installAdminUI -adminUIdir /mnt/AdminUI
```

**Note:** After you reinstall the Administration UI, keep in mind that all the Administration UI patches and hotfixes are removed from the system.



# Chapter 7: Migrating HPOM from One System to Another

## In This Chapter

This chapter describes the migration process from one system to another (for example, the migration from HPOM on HP-UX on HP Integrity to HPOM on Red Hat Enterprise Linux).

Before starting with the migration, consider the following terms used in this chapter:

**Old server:** The source management server from which you migrate HPOM.

**New server:** The target management server on which you migrate HPOM.

## Verifying Installation Requirements for the Management Server

Make sure that the new server meets at least the minimum system requirements as described in ["Installation Requirements for the Management Server" on page 13](#).

As a general rule, you must perform migrations in the following order:

1. Hardware
2. Operating system (including operating system patches)
3. Database
4. HPOM software

HPOM places no restrictions on the number of managed nodes with the 60-day Instant-On license. Make sure that you acquire the correct license for your requirements before the Instant-On license expires.

If you have a product installed that is integrated with the old server (for example, HP Performance Manager), make sure this product is compatible with a newer version of HPOM before starting the HPOM migration process. For information about how to perform the HPOM migration in this situation, see the documentation of the integrated product.

## Migration Scenarios

When migrating from one system to another, you can choose one of the following scenarios:

- ["Migration to a System with a Different IP Address and Hostname" below](#)
- ["Upgrade of the Systems in a MoM Setup by Reusing the IP Addresses and Hostnames" on page 146](#)

**Note:** Unlike the upgrade procedure described in ["Upgrading HPOM to Version 9.2x" on page 150](#), these scenarios require almost no operational downtime.

## Migration to a System with a Different IP Address and Hostname

If the hostname and the IP address of the new server are different from those of the old server, it is recommended that you configure the new server as a backup server. The basics of this scenario are as follows:

- New hardware with a new IP address and a new hostname is used for the new server.
- Depending on the setup, you can switch to the stand-alone server setup after the migration process is finished and shut down the old server.
- If the old server is to be switched off after the migration, you can request a new server permanent license in exchange for the old license (contact the HP Password Delivery Center). In the meantime, you can work on the new server with the 60-day Instant-On license.
- After setting up the new server, you can also upgrade the old server to HPOM 9.2x (for example, if a hardware cluster will be reused).
- Migration can be performed almost without operational downtime.
- Messages can be synchronized in both directions, from the old server to the new server and vice versa, whereas the configuration data exchange is only possible from the old server to the new server.
- All managed nodes must be updated with the root certificate of the new server.
- Can also be used for hardware upgrades of the same HPOM version.

To migrate to the system with the different IP address and hostname, complete these tasks:

- Task 1: ["Downloading the Old Server Configuration" on the next page](#)
- Task 2: ["Setting Up a New Server" on page 140](#)

- Task 3: ["Uploading the Saved HPOM Configuration" on the next page](#)
- Task 4: ["Establishing a Trust Relationship Between the Two Management Servers" on page 142](#)
- Task 5: ["Setting Up Message Forwarding Between the Management Servers" on page 144](#)

**Note:** For detailed information about setting up a backup server, see the *HPOM Concepts Guide*.

## Downloading the Old Server Configuration

**Note:** In case the migration is performed from HPOM 8.xx to HPOM 9.xx, templates are converted to policies. The conversion takes place automatically during the template upload. The version of all newly created policies is set to 1.0, and the version of all HPOM 9.xx delivered default policies is 9.0.

For detailed information about the HPOM policies, see the *HPOM Administrator's Reference* and the *HPOM Concepts Guide*.

To download the old server configuration, follow these steps:

1. Include service data into the download by running the following command:

```
/opt/OV/bin/ovconfchg -ovrg server -ns opc -set \  
OPC_OPCCFGDWN_ALL_INCLUDE_SELDIST_SERVICES TRUE
```

2. Create a download specification file for all configuration data:

```
echo "*" ";" > /tmp/download.dsf
```

3. Download the configuration:

```
/opt/OV/bin/OpC/opccfgdwn -force -backup /tmp/download.dsf /tmp/cfgdwn
```

4. If you want to migrate your server configuration settings, store the output of `ovconfget -ovrg server` into a file, and then transfer it to the new server.

The process of downloading the old server configuration may be repeated several times during the migration. This is because the configuration changes (for example, adding new managed nodes) take place in the old production server environment, and must, therefore, be synchronized to the new server occasionally.

**Note:** The audit records cannot be migrated from HPOM 8.xx to HPOM 9.xx. Download the audit data before migrating HPOM if you want to keep a copy of all audit entries. Enter the following command:

```
/opt/OV/bin/OpC/opcauddwn -older 0s -file /tmp/audit
```

For detailed information about the message transfer from the old server to the new server, see ["Setting Up Message Forwarding Between the Management Servers" on page 144](#).

## Setting Up a New Server

**Note:** The pure installation of the new server can be done independently of any activities in the old production server environment.

To set up a new server, follow these steps:

1. Install the HP Operations management server as described in ["Installing and Configuring HPOM on the Management Server" on page 25](#).

**Caution:** Make sure your system meets hardware and software requirements for the HPOM software installation. For information about the installation requirements, see ["Installation Requirements for the Management Server" on page 13](#).

2. Install an Oracle database or a PostgreSQL database on the new server.  
For details, see ["Installing an Oracle Database" on page 27](#) or ["Installing a PostgreSQL Database" on page 41](#).

3. After the new server and the database are installed, add the new server (the backup server) as a managed node to your old server. To do this, on the old server, run the following command:

```
/opt/OV/bin/OpC/Utils/opcnode -add_node \  
node_name=<new_server> group_name=<nodegrp_name> \  
net_type=<network_type> mach_type=<machine_type> id=<new_server_OvCoreId>
```

**Note:** You can verify that the `OvCoreId` was correctly updated in the database of the old server by running the following command:

```
/opt/OV/bin/OpC/Utils/opcnode -list_id node_list=<new_server_hostname>
```

For more information, see the *opcnode (1M)* manual page.

## Uploading the Saved HPOM Configuration

To upload the previously saved configuration with `opccfgup1d` on the new server, follow these steps:

1. Transfer the saved configuration files to the new server.
2. Stop the HP Operations management server processes:

```
/opt/OV/bin/ovc -stop SERVER
```

**Caution:** In a cluster environment, first disable the HA resource group monitoring by running the following command:

```
/opt/OV/lbin/ovharg -monitor ov-server disable
```

You must also make sure that the upload is performed on the active cluster node.

3. If you stored the output of `ovconfget -ovrg server` into a file and transferred it to the new server, follow these steps:

- a. Edit the file by running the following command:

```
/opt/OV/bin/ovconfchg -ovrg server -edit
```

- b. In the editor, merge the configuration.

Make sure that you add only the variables that you modified, and not all internal HPOM variables. Failing to do so may cause problems with the HP Operations management server installation.

To determine which variables were modified, run the following command on the old server:

```
/opt/OV/bin/ovconfchg -ovrg server -edit
```

Then compare this output with the output from the new server.

4. Upload the configuration on the new server by running the following command:

```
/opt/OV/bin/OpC/opccfgupld -replace -subentity -configured <download_directory>
```

For example:

```
/opt/OV/bin/OpC/opccfgupld -replace -subentity -configured /tmp/cfgdwn
```

5. Verify that the old server node is configured on the new server by running the following command:

```
/opt/OV/bin/OpC/utlils/opcnode -list_nodes
```

If the old server is not listed, run the following command:

```
/opt/OV/bin/OpC/utlils/opcnode -add_node \  
node_name=<old_server> group_name=<nodegrp_name> \  
net_type=<network_type> mach_type=<machine_type> id=<old_server_OvCoreId>
```

To get the `OvCoreId`, run the following command on the old server:

```
/opt/OV/bin/OpC/utlils/opcnode -list_id node_list=<old_server_hostname>
```

6. If the old server is running in an HA cluster and the new server is a stand-alone server, run the following command on the new server:

```
/opt/OV/bin/OpC/utlils/opcnode -list_virtual node_name=<new_server>
```

If a line similar to `cluster_package=ov-server` appears, run the following commands:

```
/opt/OV/bin/OpC/utlils/opcnode -set_physical node name=<new_server>  
/opt/OV/bin/OpC/utlils/opcnode -list_virtual
```

An output similar to the following one should appear:

```
node '<new_server>' is not a virtual one
```

7. Start the HP Operations management server processes:

```
/opt/OV/bin/ovc -start SERVER
```

*In a cluster environment:* Enable the HA resource group monitoring by using the following command:

```
/opt/OV/sbin/ovharg -monitor ov-server enable
```

## Establishing a Trust Relationship Between the Two Management Servers

To establish a trust relationship between the old server and the new server, follow these steps:

1. *If the old server has a Certification Authority (default):* Share the server certificates by exporting the local CA trusted certificates:

```
/opt/OV/bin/ovcert -exporttrusted -file /tmp/<hostname>.cert -ovrg server
```

For detailed information, see the *HPOM Administrator's Reference*.

2. Copy the certificate file to the new server, and then follow these steps:
  - a. Import the certificates from the old server to the new server by running the following command on the new server:

```
/opt/OV/bin/ovcert -importtrusted -file /tmp/<hostname>.cert -ovrg server
```

**Note:** To view the current certificates before importing the certificates from the old server to the new server, run the following command on the new server:

```
/opt/OV/bin/ovcert -list
```

- b. On the new server, propagate the trusted certificates of the old server to the local agent by running the following command:

```
/opt/OV/bin/ovcert -updatetrusted
```

To check whether an additional CA trusted certificate is installed, list the installed certificates by running the following command:

```
/opt/OV/bin/ovcert -list
```

3. Import the CA trusted certificate of the new server to the old server. To do so, follow these steps:

- a. On the new server, run the following command:

```
/opt/OV/bin/ovcert -exporttrusted -file /tmp/<hostname>.cert -ovrg server
```

- b. Copy the file to the old server, and then import the certificates there:

```
/opt/OV/bin/ovcert -importtrusted -file /tmp/<hostname>.cert -ovrg server
```

**Note:** Because the file contains all trusted certificates from the old server, you will receive a warning that the certificate is already installed.

- c. On the old server, propagate the new server's trusted certificates to the local agent by running the following command:

```
/opt/OV/bin/ovcert -updatetrusted
```

To check whether the additional CA trusted certificate is installed, list the installed certificates by using the following command:

```
/opt/OV/bin/ovcert -list
```

4. Configure the flexible management policy on the old server:

- *If you have the MoM setup:* Add the new server to the `/etc/opt/OV/share/conf/OpC/mgmt_sv/respmgrs/allnodes` file, and then verify the syntax:

```
/opt/OV/bin/OpC/opcmomchk allnodes
```

- *If you do not have the MoM setup:* The system contains several example files that are located in the following directory:

```
/etc/opt/OV/share/conf/OpC/mgmt_sv/tmp1_respmgrs
```

Create a copy of the backup server example policy, and then modify it to reflect your own configuration. To confirm that the file syntax is configured correctly in the new policy file, run the following command:

```
/opt/OV/bin/OpC/opcmomchk <policy_filename>
```

Name the file `allnodes` and copy it to the following directory:

```
/etc/opt/OV/share/conf/OpC/mgmt_sv/respmgrs
```

5. Deploy the flexible management policy to all nodes. On the old server, run the following command:

```
/opt/OV/bin/OpC/opcragt -distrib -policies -all
```

Make sure that you update the trusted certificates on the remote agents. In the Java GUI, mark all the managed nodes, and then start the `Update Trusts` application in the `Certificate Tools` application group.

6. On the new server, check if the agents can be contacted:

```
/opt/OV/bin/OpC/opcragt -status -all
```

Run the command on the old server as well, and then compare its output with the output of the new server.

**Note:** On the old server, you can use multiple threads for the `opcragt` command by running the following command:

```
/opt/OV/bin/ovconfchg -ovrg server -ns opc -set OPCRAGT_USE_THREADS TRUE
```

On the new server, `opcragt` is multi-threaded by default.

**Note:** The agents that could not be contacted are listed in the following file:

```
/var/opt/OV/share/tmp/OpC/mgmt_sv/opcragt-status-failed
```

7. Copy the `allnodes` file from the old server to the new server. The file location is the following:

```
/etc/opt/OV/share/conf/OpC/mgmt_sv/respmgrs/allnodes
```

8. *Ignore this step at this point.* You can perform this step later if you plan to shut down the old server when the new server is up and running, and the old server is still referenced in the settings.

Change the following configuration variables on all affected agents:

```
sec.core.auth:MANAGER  
sec.core.auth:MANAGER_ID  
sec.cm.client:CERTIFICATE_SERVER
```

On either of the servers, run the following commands:

```
/opt/OV/bin/OpC/opcragt -set_config_var \  
sec.cm.client:CERTIFICATE_SERVER=<new_server_hostname> <node_list>  
  
/opt/OV/bin/OpC/opcragt -set_config_var \  
sec.core.auth:MANAGER=<new_server_hostname> <node_list>  
  
/opt/OV/bin/OpC/opcragt -set_config_var \  
sec.core.auth:MANAGER_ID=<new_server_core_id> <node_list>
```

In these instances, *<node\_list>* is usually *-all*.

9. *Ignore this step at this point.*

In a server pooling environment, perform this step when the new server is up and running.

To configure all managed nodes to use the new server as the primary manager, run the following command on the new server:

```
/opt/OV/bin/OpC/opcragt -primmgr -all
```

10. *Optional:* You can upgrade the managed nodes to the latest version at any time later on. For more information, see ["Upgrading the HP Operations Agent Software" on page 174](#).

## Setting Up Message Forwarding Between the Management Servers

When the new server is completely functioning, the messages must be synchronized. It is recommended to have a shadow period during which the new server acts as a backup server for the old server. The shadow period can last only several hours, but it can also take days or weeks, depending on the company requirements.

**Note:** Only new incoming messages are synchronized by using message forwarding. All the messages that had arrived before the shadow period began must be handled on the old server.

To set up message forwarding between the servers, follow these steps:

1. Prepare the following configuration file on the old server:

```
/etc/opt/OV/share/conf/OpC/mgmt_sv/respmgrs/msgforw
```



- *If you have the MoM with message forwarding setup:* Add the new server to the existing `msgforw` file, and then verify the syntax by running the following command:  
`/opt/OV/bin/OpC/opcmomchk`
- *If you do not have the MoM with message forwarding setup:* The system contains an example file that is located in the following directory:  
`/etc/opt/OV/share/conf/OpC/mgmt_sv/tmp1_respmgrs`  
Create a copy of the `msgforw` example policy and modify it to reflect your own configuration. The following is an excerpt for a two server setup:

```
...
MSGTARGETRULE
DESCRIPTION "forward all messages"
MSGTARGETRULECONDS
MSGTARGETMANAGERS
MSGTARGETMANAGER
TIMETEMPLATE "$OPC_ALWAYS"
OPCMGR IP 0.0.0.0 "<new_server_hostname>"
MSGCONTROLLINGMGR
MSGTARGETMANAGER
TIMETEMPLATE "$OPC_ALWAYS"
OPCMGR IP 0.0.0.0 "<old_server_hostname>"
MSGCONTROLLINGMGR
...
```

**Caution:** Both servers must be mentioned in the message target rule and the `MSGCONTROLLINGMGR` keyword must be used.

For detailed information, see the *opcmom(4)* manual page.

To confirm that the file syntax is configured correctly in the new policy file, run the following command:

```
/opt/OV/bin/OpC/opcmomchk <policy_filename>
```

Name the file `msgforw`, and copy it to the following directory:

```
/etc/opt/OV/share/conf/OpC/mgmt_sv/respmgrs
```

2. Make sure that message forwarding is enabled on the old server.
3. Check message forwarding as follows:
  - a. Create several messages, and then check if they arrive in the GUI connected to the new server.
  - b. Acknowledge the message on the new server, and then check if it is synchronized to the old server.
4. Set up message forwarding on the new server when the agents send the messages directly to the

new server. To do so, reuse the `msgforw` file from the old server:

- a. Copy the `msgforw` file from the old server to the new server, and then put it into the following directory:

```
/etc/opt/OV/share/conf/OpC/mgmt_sv/respmgrs
```

- b. On the new server, run the following command:

```
/opt/OV/bin/ovconfchg
```

After the shadow period is over, follow these steps:

1. Make sure that the operators start using the new server.

For detailed information, see the *HPOM Administrator's Reference*.

2. *Optional:* Download and upload the history messages from the old server to the new server as follows:

- a. On the old server, run the following command:

```
/opt/OV/bin/OpC/opchistdown -until <start_of_shadow_period> \  
-file /tmp/history
```

In this instance, `<start_of_shadow_period>` is a timestamp in the `mm/dd/yy` format.

- b. Copy the file to the new server, and then run the following command:

```
/opt/OV/bin/OpC/opchistup1 /tmp/history
```

**Note:** If the HPOM 8.xx installation has non-ASCII characters in the messages, use the `-upgrade` option to convert the messages from the HPOM 8.xx character set to the HPOM 9.xx character set. For example:

```
LANG=en_US.utf8 /opt/OV/bin/OpC/opchistup1 -upgrade ja_JP.SJIS \  
/tmp/history
```

## Upgrade of the Systems in a MoM Setup by Reusing the IP Addresses and Hostnames

This scenario uses the concept of the MoM backup server. Therefore, this scenario can only be applied in the MoM setups. While upgrading to the new server, one server is put into the maintenance mode and the other server completely takes over. The basics of this scenario are the following:

- Server IP addresses, hostnames, and certificates are reused.
- It is not important if a new hardware is introduced or the existing hardware is reused—IP addresses and hostnames are taken over.
- Existing permanent license of the old server that is upgraded to HPOM 9.2x can be reused. However, if this is not possible, request a new server's permanent license in exchange for the old

license. For details, contact the HP Password Delivery Center.

- Upgrade process can be performed almost without operational downtime.
- Messages can be synchronized in both directions, from the old server to the new server, and vice versa, whereas the configuration data exchange is possible only from the old server to the new server.
- Agents do not have to be updated because the server's certificates, the private keys, and the OvCoreId are reused.
- Can also be used for the hardware upgrades of the same HPOM version.

**Note:** Because this scenario basically represents a subcase of the upgrade procedure described in ["Upgrading HPOM to Version 9.2x" on page 150](#), only the specifics of the MoM upgrade are described in this section.

## Upgrading Systems in a MoM Setup by Reusing IP Addresses and Hostnames

To upgrade the systems in the MoM setup by reusing the IP addresses and the hostnames, assume you have server A and server B, and all agents currently report to server A. Then assume that server A shall be upgraded. Continue as follows:

1. *Ignore this step in a server pooling environment:* Switch all agents to report to server B. On server B, run the following command:

```
/opt/OV/bin/OpC/opcragt -primmgr -all
```

2. Make sure that message forwarding between server A and server B is switched to HTTPS communication.

If required, perform the following steps on both servers:

- a. Enable HTTPS-based message forwarding by running the following command:

```
/opt/OV/bin/ovconfchg -ovrg server -ns opc -set OPC_HTTPS_MSG_FORWARD TRUE
```

- b. Restart processes on both servers:

```
/opt/OV/bin/ovc -stop  
/opt/OV/bin/ovc -start
```

- c. Verify that HTTPS-based message forwarding works correctly by sending several test messages and acknowledging them. In addition, check that message synchronization works correctly.

3. Stop server A.

From the moment you stop server A, server B starts buffering all messages and message operations. Run the following command:

```
/opt/OV/bin/ovc -stop
```

**Note:** During the upcoming upgrade installation of server A, it can happen that server B sends buffered messages as soon as server A is up.

4. If server A is to be replaced by a new hardware, back up its certificates and the OvCoreId:

```
/opt/OV/bin/OpC/opcsvcertbackup -backup \  
-passwd <password> -file <my_cert_backup>
```

In this instance, *<my\_cert\_backup>* is the file where you backed up the certificates.

5. To upgrade the management server, see ["Upgrading HPOM to Version 9.2x" on page 150](#).
6. *Ignore this step if the old hardware of server A was reused:* If server A was replaced by a new hardware, the initial installation generated a new OvCoreId and new certificates. Server B cannot forward messages to server A at this point. Therefore, you must reinstall the saved OvCoreId and certificates. Run the following commands:

```
/opt/OV/bin/ovc -kill  
/opt/OV/bin/OpC/opcsvcertbackup -restore \  
-passwd <password> -file <my_cert_backup> -force
```

In this instance, *<password>* is the same password as you used for backing up the certificates and the OvCoreId of server A and *<my\_cert\_backup>* is the file where you backed up the certificates.

It may happen that in the meantime certain configuration changes are done on server B.

7. Make sure that you synchronize the servers:

- a. On server B, run the following commands:

```
echo "*" ;" >/tmp/all.dsf  
mkdir /tmp/all  
/opt/OV/bin/OpC/opccfgdwn -backup /tmp/all.dsf /tmp/all
```

- b. On server A, run the following command:

```
/opt/OV/bin/OpC/opccfgupld -replace -subentity <data_from_B>
```

In this instance, *<data\_from\_B>* is the data downloaded from server B.

8. Start server processes on server A by running the following command:

```
/opt/OV/bin/ovc -start
```

**Note:** At this point, server B can forward all messages and message operations that were buffered.

9. *Ignore this step in a server pooling environment:*

*Optional:* Switch the agents back to server A. On server A, run the following command:

```
/opt/OV/bin/OpC/opcragt -primmgr -all
```

# Chapter 8: Upgrading HPOM to Version 9.2x

## In This Chapter

This chapter describes how to upgrade from HPOM 8.xx or HPOM 9.1x to HPOM 9.2x on the same system.

**Note:** You can either upgrade the software on the same system, as described in the following sections, or migrate your data to a new HPOM 9.2x installation on a different system. For detailed information about migrating HPOM, see ["Migrating HPOM from One System to Another" on page 137](#).

In this chapter, you can also find information about the following topics:

- ["Upgrading an HPOM Database" on page 165](#)
- ["Upgrading the Java GUI" on page 173](#)
- ["Upgrading the HP Operations Agent Software" on page 174](#)
- ["Migrating Licenses to HPOM 9.2x" on page 174](#)

**Caution:** The HP Operations agent software is no longer shipped together with HPOM. To obtain the supported agent version, request the agent media 11.1x from HP.

## Upgrading from HPOM 8.xx to HPOM 9.2x

To upgrade HPOM from version 8.xx to version 9.2x, complete these tasks:

- Task 1: ["Verifying the Installation Requirements for the Management Server" on the next page](#)
- Task 2: ["Backing Up the Current HPOM 8.xx Installation " on the next page](#)
- Task 3: ["Downloading the Current HPOM 8.xx Configuration " on page 152](#)
- Task 4: ["Installing a New Database Version " on page 154](#)
- Task 5: ["Upgrading an Old Version of HPOM" on page 156](#)
- Task 6: ["Uploading the Saved HPOM Configuration " on page 158](#)

- [Task 7: "Upgrading the Java GUI" on page 173](#)
- [Task 8: "Upgrading the HP Operations Agent Software" on page 174](#)

## Verifying the Installation Requirements for the Management Server

Make sure that the new management server meets at least the minimum system requirements as described in ["Installation Requirements for the Management Server" on page 13](#).

Note which versions of the operating system and the database are required to upgrade the HPOM software. As a general rule, you must perform the upgrade in the following order:

1. Hardware
2. Operating system (including operating system patches)
3. Database
4. HPOM software

HPOM places no restrictions on the number of managed nodes with the 60-day Instant-On license. Make sure that you acquire the correct license for your requirements before the Instant-On license expires.

If you have a product installed that is integrated into or certified with HPOM 8.xx (for example, HP Performance Manager), make sure this product is compatible with HPOM 9.2x before starting the HPOM upgrade procedure. For information about how to perform the HPOM upgrade in this situation, see the documentation of the integrated product.

## Backing Up the Current HPOM 8.xx Installation

To back up the current HPOM installation, follow these steps:

1. Exit all GUIs.
2. Stop all other applications on the system.
3. Make a full backup of the current installation:
  - a. Enter the following:

```
/opt/0V/bin/OpC/opc_backup
```

The system prompts you with the following:

```
Do you want to use the full or configuration backup?  
(f|c) ==>
```
  - b. Enter **f** for a full backup, which includes the HPOM binaries and the configuration data.  
The system prompts you with the following:

- Do you want to back up another directory, too?  
(y|n) ==>
- c. Enter **y** (yes) or **n** (no) as required.  
The system prompts you with the following:  
Please enter the backup destination:
  - d. Enter a file name for the backup data, for example, /tmp/opc\_backup\_full\_hpom, or enter a tape device.
  - e. Store the backup data on backup media or a separate system. For more information, see the *opc\_backup(1M)* manual page.

**Note:** With HPOvSecCS 11.13.007 or higher, the default RSA key length is increased (from 1024 to 2048 bits). Therefore, a new CA certificate is created with a new key length on the server.

As part of the upgrade, a new CA certificate with the alias `CA_<ovcoreid>_<ASYMMETRIC_KEY_LENGTH>` is added. Before upgrading to HPOM 9.2x, it is strongly recommended to upgrade HPOvSecCS to 11.13.007 or higher on the HPOM 8.xx management server, and to save the management server certificates and the `OvCoreId` of the HPOM 8.xx management server.

### Backing Up Management Server Certificates

To make a copy of the old management server certificates, run the following command:

```
/opt/OV/bin/OpC/opcsvcertbackup -backup -passwd <passwd> -file <old_certs>
```

In this instance, `<passwd>` is the user password and `<old_certs>` is the file with the old management server certificates.

If you omit the `-file` option, a `.tar` archive file is created at the following default location:

```
/tmp/opcsvcertbackup.<date_time>.tar
```

**Note:** Make sure that the `OvCoreId` and certificates of the old management server are reused after the HP Operations management server installation. Otherwise, the managed nodes cannot communicate with the management server.

## Downloading the Current HPOM 8.xx Configuration

This section describes the procedure for downloading the current HPOM 8.xx configuration. With HPOM 9.xx, a new concept of policy management is introduced, therefore it is very important that you get acquainted with the basics described in "[Converting Templates to Policies](#)" on the next page before continuing with the procedure for downloading the current HPOM 8.xx configuration.



## Converting Templates to Policies

Consider the following basics before you download the current HPOM 8.xx configuration:

- With HPOM 9.xx, templates are converted to policies. The conversion takes place automatically during the template upload. The version of all newly created policies is set to 1.0, and the version of all HPOM 9.xx delivered default policies is 9.0.
- All HPOM 8.xx template assignments to nodes, node groups, and template groups will point to 1.0 policy versions after the migration to HPOM 9.xx.  
  
All HPOM 8.xx template assignments are converted into fix version policy assignments. During the migration from HPOM 8.xx to HPOM 9.xx, the LATEST and MINOR\_TO\_LATEST assignments are not created.
- Managed nodes that are mentioned in policies are no longer resolved to node objects in the HPOM 9.xx database. For example, assume that you specified an action node with the IP address in the template and now the IP address was changed in the database. The HPOM 9.xx policy points to the old IP address, whereas the HPOM 8.xx template was updated automatically. For that reason, it is recommended to use node names in policies. If the IP address is used, make sure that you edit all the policies referencing that IP address if the IP address was changed.
- All HPOM 8.xx monitor templates are converted into monitor threshold policies during the migration. Although the policies seem to be different in terms of the syntax, they are in fact semantically identical to the templates.
- During the migration, the template group names that contain a slash character (/) or a backslash character (\) are converted to use an underscore character (\_) instead. For example, the SPI for SAP R/3 template group name is renamed to SPI for SAP R\_3.
- All assignments of template groups are migrated as described in the following example:

### Example of Migration of All Assignments of Template Groups

Assume that the G/C HPOM 8.xx template group is assigned to the G/A and G/B groups. Now also assume that the NG node group has G/C assigned, and that the T template is assigned to G/C.

The following actions take place during the migration:

- G/A is renamed to G\_A, G/B to G\_B, and G/C to G\_C.
- The /G\_A, /G\_A/G\_C, /G\_B, and /G\_B/G\_C policy groups are created.
- The T policy (version 1.0) will be assigned to the /G\_A/G\_C and /G\_B/G\_C policy groups.
- The NG node group has an assignment to the /G\_A/G\_C and /G\_B/G\_C policy groups.

**Note:** For detailed information about HPOM policies, see the *HPOM Administrator's Reference*

and the *HPOM Concepts Guide*.

## Procedure for Downloading the Current HPOM 8.xx Configuration

To download the current HPOM 8.xx configuration, follow these steps:

1. Create a new user or modify an existing user in the User Bank.  
This user must have full responsibility for all message groups and node groups. You will need this user later to acknowledge all active messages. You can use `opc_adm` for this purpose.
2. Verify that all running Java GUIs are stopped by running the following command:  

```
ps -eaf | grep opcu
```
3. Stop the HP Operations server processes by running the following command:  

```
/opt/OV/bin/ovstop
```
4. Stop the local agent on the management server by running the following command:  

```
/opt/OV/bin/OpC/opcagt -kill
```
5. *Optional:* Download the service data by running the following command:  

```
ovconfchg -ovrg server -ns opc \  
-set OPC_OPCCFGDWN_ALL_INCLUDE_SELDIST_SERVICES TRUE
```
6. Download configuration data:
  - a. Create an empty download specification file:  

```
echo "*" ;" > /tmp/download.dsf
```
  - b. Download the configuration:  

```
/opt/OV/bin/OpC/opccfgdwn /tmp/download.dsf /tmp/cfgdwn
```
7. *Optional:* Migrate active messages by following these steps:
  - a. Perform a history download by running the following command:  

```
/opt/OV/bin/OpC/opchstdwn -older 0s -file /tmp/history
```
  - b. Acknowledge all active messages by running `opcack` for the user you previously set up:  

```
/opt/OV/bin/OpC/opcack -u <user_for_all_msg_grps> -a -f
```
  - c. Perform a second history download by running the following command:  

```
/opt/OV/bin/OpC/opchstdwn -older 0s -file /tmp/active
```
8. *Optional:* Migrate server configuration settings. To do this, store the output of `ovconfget -ovrg server` into a file.

## Installing a New Database Version

[Table 20](#) shows which database versions are supported with HPOM 9.2x.

Table 20: Supported Database Versions

| Oracle Database Version         | PostgreSQL Database Version |
|---------------------------------|-----------------------------|
| • 11gR1 (11.1.0.7)              | • 9.1                       |
| • 11gR2 (11.2.0.1–11.2.0.4)     | • 9.2                       |
| • 12cR1 (12.1.0.1 and 12.1.0.2) | • 9.3                       |
|                                 | • 9.4                       |

For detailed information about installing an Oracle database or a PostgreSQL database, see ["Installing an Oracle Database" on page 27](#) or ["Installing a PostgreSQL Database" on page 41](#).

## Database Specifics

Depending on which database you plan to use with HPOM 9.2x, when installing a new database version, keep in mind the following:

- *If you plan to use the Oracle database:*
  - If you do not use Oracle 11g with HPOM 8.31 or higher, make sure that both versions of the Oracle database server (that is, Oracle 9i or Oracle 10g for HPOM 8.xx and Oracle 11g or Oracle 12c for HPOM 9.2x) are installed on the management server before upgrading to HPOM 9.2x. During the upgrade, the old database is removed and a new database for HPOM 9.2x is configured.
  - If you used the Oracle database version 11.1.0.6 with HPOM 8.xx, make sure that you upgrade it to 11.1.0.7 or higher before starting the upgrade procedure.
  - You can remove the old Oracle database version from the system after the upgrade if you do not need it anymore.
  - The `.profile` file for the Oracle user may contain the `ORACLE_HOME`, `ORACLE_SID`, or `ORACLE_BASE` variable. If this is true, it is important to set them correctly during the different phases of the upgrade:
    - Before installing the new Oracle database server, the variables must be set so that they point to the new Oracle database server (that is, the database server that is used with HPOM 9.2x).
    - During the first steps of the upgrade, you must set the variables according to the old Oracle database server (that is, the database server that is used with HPOM 8.xx).
    - After the old database is removed, you must set the variables according to the new server configuration before continuing with the upgrade procedure.
- *If you plan to migrate from the Oracle database to the PostgreSQL database:*

- It is highly recommended that you back up the whole Oracle database before starting the migration procedure.
- The old version of the Oracle database and the PostgreSQL binaries must be installed before upgrading to HPOM 9.2x. During the upgrade, the old database is removed and the new database for HPOM 9.2x is configured. For details, see "[Migrating from Oracle to PostgreSQL](#) " on page 163.
- You can remove the old Oracle database from the system after the upgrade if you do not need it anymore.

## Upgrading an Old Version of HPOM

The standard upgrade procedure can be executed by running the `ovoupgrade_8xto92` script that is available for download from the following location:

[https://softwaresupport.hpe.com/group/softwaresupport/search-result/-/facetsearch/document/KM02669472?lang=en&cc=us&hpappid=202392\\_SSO\\_PRO\\_HPE](https://softwaresupport.hpe.com/group/softwaresupport/search-result/-/facetsearch/document/KM02669472?lang=en&cc=us&hpappid=202392_SSO_PRO_HPE)

**Caution:** Before starting the upgrade procedure, you must remove server add-on packages (different products that were installed additionally, that is, outside the HPOM 8.xx server installation).

To upgrade an old version of HPOM, follow these steps:

1. Download the `ovoupgrade_8xto92` script.
2. Start the HPOM upgrade procedure:
  - If you are upgrading HPOM from a DVD-ROM, copy the `ovoupgrade_8xto92` script to `/tmp`, and then type the following:  

```
/tmp/ovoupgrade_8xto92
```
  - If you are upgrading HPOM using DVD content, copy the `ovoupgrade_8xto92` script to `<master_directory>/HPOMDVD/`.

For example, if you create the `/tmp` directory as a master directory, copy the `ovoupgrade_8xto92` script to `/tmp/HPOMDVD/`, and then start it by typing the following:

```
/tmp/HPOMDVD/ovoupgrade_8xto92
```

**Caution:** In a cluster environment, the `ovoupgrade_8xto92` script must be run on all cluster nodes.

Make sure that you first perform the upgrade procedure on the active cluster node, and then on all passive cluster nodes. During the upgrade procedure on all passive cluster nodes, you may not perform a server switchover.

The following text appears:

Welcome to the HP Operations Manager for UNIX upgrade

Press **ENTER** to verify that you want the upgrade procedure to start.

The `ovupgrade_8xto92` script checks the HP Operations management server version. If the version is correct, you are prompted to enter the HPOM software package repository location where all server packages are located.

3. Press **ENTER** to accept the default repository location, or enter the desired location followed by **ENTER**.

You are prompted to enter the HP Operations agent software location.

4. After you enter the HP Operations agent software location, press **ENTER**.

You are prompted to enter the HPOM Administration UI software location.

5. After you enter the HPOM Administration UI software location, press **ENTER**.

The `ovupgrade_8xto92` script stops the management server and continues with removing SPIs, the database, the documentation, the agent software, the server software, and Core components.

**Note:** If any of the removal steps returns a `FAILED` value, type `repeat` to repeat the step. However, if the `FAILED` value is the result of the package dependency check, you can safely skip that step.

The `ovupgrade_8xto92` script continues with removing NNM software. You can choose between removing only the NNM software and removing the NNM data and software.

6. Choose the Remove NNM Data and Software option that removes NNM databases, log files, configuration files, data warehouse reports, ECS circuits, and user modifiable files from your system.

The `ovupgrade_8xto92` script asks you if you want to continue with removing the NNM data and software.

7. Press **y** followed by **ENTER** to continue.

If you want to check the progress of the NNM data and software removal process, run the following command in a separate terminal window:

```
tail -f /var/adm/sw/swagent.log
```

**Caution:** Make sure that you do not use the `kill` command or `Control-C` to stop the NNM data and software removal process because it may result in system corruption.

8. After the `ovupgrade_8xto92` script checks and installs the server setup package that contains the server installation infrastructure, press **ENTER** to continue with installing and configuring the HPOM software on the management server.

For detailed information about the installation and configuration steps, see ["Installing and Configuring the HPOM Software on the Management Server" on page 46](#).

**Note:** After installing the HPOM software on the management server, make sure that the management server certificates and the `OvCoreId` are identical before and after the installation. If they are not identical, or if they even do not exist, you can reinstall them by running the following command:

```
/opt/OV/bin/OpC/opcsvcertbackup -restore -passwd <passwd> \  
-file <old_certs> -force
```

In this instance, `<passwd>` is the user password and `<old_certs>` is the file with the old management server certificates.

When the management server installation is finished, the HPOM 8.xx configuration can be uploaded to HPOM 9.2x.

## Uploading the Saved HPOM Configuration

To upload the previously saved configuration on the newly installed management server with `opccfgupld`, follow these steps:

1. *In a cluster environment only:* Disable the HA resource group monitoring by running the following command:

```
/opt/OV/lbin/ovharg -monitor ov-server disable
```

2. If you stored the output of `ovconfget -ovrg server` into a file, perform the following:

- a. Run the following command:

```
ovconfchg -ovrg server -edit
```

- b. In the editor, merge the configuration.

Make sure that you add only the variables that you modified, and not all internal HPOM variables. Failing to do so may cause problems with the server installation.

To determine which configuration settings were modified, first call `ovconfget -ovrg server` on the HPOM 9.2x installation, and then compare this output with the `ovconfget -ovrg server` output stored from the HPOM 8.xx installation.

3. Stop the HP Operations server processes by running the following command:

```
/opt/OV/bin/ovc -stop SERVER
```

4. Upload the configuration data:

```
opccfgupld -add -subentity -configured -upgrade <Language_subdirectory> \  
<download_directory>
```

For example:

```
opccfgupld -add -subentity -configured -upgrade ja_JP.SJIS /tmp/cfgdwn
```

5. After uploading data with `-add -subentity`, you can upload the data with `-replace -subentity` if you exclude the managed nodes:

- a. Copy the index file of the download:

```
download_directory /$LANG/*.idx
```

For example:

```
cp /tmp/cfgdwn/C/cfgdwn.idx /tmp/cfgdwn/C/nonodes.idx
```

- b. Modify the copied index file.

Remove the node bank section from the index file. This includes everything from the `ENTITY NODE_BANK` line to the semicolon before the node defaults:

```
;  
ENTITY NODE_DEFAULTS *
```

Remove the following line if it exists:

```
CONTENTS *;
```

- c. Upload your configuration data by running the following command:

```
opccfgupld -replace -subentity -configured -upgrade <old_locale> \  
-index <index_file> <upload_directory>
```

In this instance, `<index_file>` is the copied index file of the download.

For example:

```
opccfgupld -replace -subentity -configured -upgrade ja_JP.SJIS \  
-index /tmp/cfgdwn/C/nonodes.idx /tmp/cfgdwn
```

HPOM 9.2x requires a UTF-8 locale to be used. Because the downloaded data is stored according to the old HPOM locale, the `opccfgupld` command might not find the data if you do not include the `-upgrade <old_locale>` option.

6. Start the HP Operations server processes by running the following command:

```
/opt/OV/bin/ovc -start SERVER
```

If you downloaded active messages, upload them by following these steps:

- a. Upload the active messages from your download:

```
/opt/OV/bin/OpC/opchistup1 /tmp/active
```

**Note:** If the HPOM 8.xx installation has non-ASCII characters in the messages, use the `-upgrade` option to convert the messages from the HPOM 8.xx character set to the HPOM 9.xx character set. For example:

```
LANG=en_US.utf8 /opt/OV/bin/OpC/opchistup1 -upgrade ja_JP.SJIS \  
/tmp/active
```

- b. Unacknowledge the active messages in the history message browser and disown them in the message browser by using the Java GUI.

For detailed information, see the *HPOM Java GUI Operator's Guide*.

- c. Upload the history messages:

```
/opt/OV/bin/OpC/opchistup1 /tmp/history
```

**Note:** If the HPOM 8.xx installation has non-ASCII characters in the messages, use the `-upgrade` option to convert the messages from the HPOM 8.xx character set to the HPOM 9.xx character set. For example:

```
LANG=en_US.utf8 /opt/OV/bin/OpC/opchistup1 -upgrade ja_JP.SJIS \  
/tmp/history
```

7. *In a cluster environment only:* Enable the HA resource group monitoring by running the command:

```
/opt/OV/sbin/ovharg -monitor ov-server enable
```

**Note:** Before enabling the HA resource group monitoring, make sure that the HP Operations management server is running.

After the upgrade, specific customized configuration files can be restored from the backup, if needed.

## Upgrading from HPOM 9.1x to HPOM 9.2x

To upgrade HPOM from version 9.1x to version 9.2x, complete these tasks:

- Task 1: ["Verifying Installation Requirements for the Management Server" below](#)
- Task 2: ["Upgrading HPOM from Version 9.1x to Version 9.2x" on the next page](#)

## Verifying Installation Requirements for the Management Server

When verifying installation requirements for the management server, do the following:

- Make sure that the new management server meets at least the minimum system requirements as described in ["Installation Requirements for the Management Server" on page 13](#).
- Make sure that HPOM 9.1x is installed and configured on the system on which the upgrade is performed.



- If the upgrade is performed in a cluster environment, make sure that HPOM 9.1x is installed and configured in the cluster environment.

## Upgrading HPOM from Version 9.1x to Version 9.2x

To upgrade HPOM from version 9.1x to version 9.2x, follow these steps:

1. Back up server certificates and the `OvCoreId` by running the following command:

```
/opt/OV/bin/OpC/opcsvcertbackup -backup
```

2. Start the HPOM upgrade procedure:

- If you upgrade HPOM from a DVD-ROM, type the following:

```
<mount_point>/ovupgrade
```

In this instance, `<mount_point>` is the location where the HPOM installation DVD is mounted.

- If you upgrade HPOM using DVD content, type the following:

```
<master_directory>/HPOMDVD/ovupgrade
```

For example, if you created the `/tmp` directory as the master directory, you can start `ovupgrade` by typing the following:

```
/tmp/HPOMDVD/ovupgrade
```

The following text appears:

```
Welcome to the HP Operations Manager for UNIX upgrade
```

3. Press **ENTER** to verify that you want the upgrade procedure to start.

The `ovupgrade` script continues with detecting special environments and creating a file permission snapshot.

**Caution:** *In a cluster environment:* You must first perform the upgrade procedure on the active cluster node, and then on all passive cluster nodes. During the upgrade procedure on the passive cluster nodes, make sure not to perform a server switchover.

You are prompted to enter the HPOM software package repository location where all server packages are located.

4. Press **ENTER** to accept the default repository location, or enter the desired location followed by **ENTER**.

You are prompted to enter the HP Operations agent software location.

5. After you enter the HP Operations agent software location, press **ENTER**.

You are prompted to enter the HPOM Administration UI software location.

6. After you enter the HPOM Administration UI software location, press **ENTER**.

The `ovoupgrade` script checks which patches are installed and removes them. After deleting the patches, it checks and installs the server setup package that contains the server installation infrastructure.

7. Press **ENTER** to continue with detecting installed software.

The `ovoupgrade` script informs you about the software that will be removed.

8. Press **ENTER** to continue with the software removal.

The `ovoupgrade` script continues with installing the local agent. After the process of installing the local agent returns the OK value, it checks core component packages, server packages, localization packages, and ECS Composer packages.

9. Press **ENTER** to continue with installing the packages.

After all the packages are installed, the following note is displayed:

```
Before continuing with the server configuration, you can manually install
available server patches.
```

10. *Optional:* Install the patches.

- a. Open a second window and install the latest versions of the following patches:

- o Consolidated Server and Java GUI
- o Core and Accessories

- b. Close the second window after you have successfully installed the patches. Return to the original window to continue with the upgrade.

11. Press **ENTER** to continue.

The `ovoupgrade` script performs the integration into the start/stop sequence and installs agent deployment packages.

12. If you want to enable the Event Storm Filter component, press **ENTER**. Otherwise, press **n** followed by **ENTER**.

For detailed information about the Event Storm Filter component, see the *HPOM Administrator's Reference*.

13. If you want to enable the Health Check component, press **ENTER**. Otherwise, press **n** followed by **ENTER**.

For detailed information about the Health Check component, see the *HPOM Administrator's Reference*.

14. Press **ENTER** to confirm that you want to install the server add-on packages.

After the server add-on packages are installed, the `ovoupgrade` script asks you if you want to migrate your database from Oracle to PostgreSQL.

15. Press **ENTER** to accept the default value **n** and not to migrate from the Oracle database to the PostgreSQL database, or press **y** followed by **ENTER** and start the migration from the Oracle

database to the PostgreSQL database. For more information, see "[Migrating from Oracle to PostgreSQL](#) " below.

The ovupgrade script displays messages that the Administration UI is upgraded and the server is started. The Administration UI is upgraded to the HPOM 9.20 version.

16. If you want to switch HPOM to non-root operation, press **y** followed by **ENTER**. Otherwise, accept the default value **n** by pressing **ENTER**.

For detailed information about non-root operation, see the *HPOM Concepts Guide*.

Before the ovupgrade script completes the upgrade procedure, it informs you about the commands that you must run if you want to revert file permission changes made during the upgrade. An output similar to the following one appears:

You can revert file permission changes made during the upgrade by running the following commands:

```
/opt/OV/bin/OpC/install/ovoconfigure -revertPermissions  
/opt/OV/bin/OpC/install/file_permissions.09.10.240.conf
```

**Caution:** If you decided to switch HPOM to non-root operation, make sure not to revert file permission changes.

17. *Optional:* Install the latest Administration UI patch.

## Migrating from Oracle to PostgreSQL

If you decided to migrate your Oracle database to PostgreSQL, follow these steps:

1. Answer the questions listed in [Table 21](#) by either accepting the default value and pressing **ENTER**, or typing the desired value followed by **ENTER**.

Table 21: Oracle to PostgreSQL-related Migration Questions

| Question  | Description and/or Default Value  |
|---|---|
| Do you wish HPOM to manage the PSQL cluster ( n for independent / remote scenarios )? | Depending on whether you want to have a managed database (HPOM manages a local database that will be created from the beginning or was created by using the psqlcluster tool) or an independent database (HPOM connects to an independent local or remote database, but does not manage it), choose y or n. |
| Clear and re-initialize the tables if they already exist?                             | y   |

Oracle to PostgreSQL-related Migration Questions, continued

| Question  | Description and/or Default Value  |
|---|---|
| PSQL cluster directory  | The main directory where the PostgreSQL cluster is stored.  |
| PSQL binary directory   | The directory where the PostgreSQL binaries are stored. Keep in mind that the location of this directory varies depending on the distribution or the version.                                   |
| PSQL library directory  | The directory where the PostgreSQL client libraries are stored. Keep in mind that the location of this directory varies depending on the distribution or the version.                           |
| PSQL data directory   | The directory where the data tablespaces are stored. This directory must be empty or non-existent. If you do not provide an answer to this question, <i>&lt;cluster_dir&gt;/HPOM</i> is used.   |
| PSQL index directory  | The directory where the index tablespaces are stored. This directory must be empty or non-existent. If you do not provide an answer to this question, <i>&lt;cluster_dir&gt;/HPOM</i> is used.  |
| Do you wish to start the PSQL cluster automatically at boot time? | Press <b>y</b> if you want the database cluster to be started automatically each time the system is started. Otherwise, you must start the database cluster manually before you can start HPOM. |
| Hostname  | The system on which the database cluster or server is installed.  |
| Port  | The port on which the database cluster or server listens. It is usually set to 5432 or 5444.<br><br>Make sure no other process uses this port at any time, including after a system restart.    |
| Database name   | The name of the HPOM database. The default is <i>openview</i> .   |
| OS DBA user   | The operating system user that controls database processes and has access to all PostgreSQL binaries and HPOM database directories. This user is usually set                                    |

Oracle to PostgreSQL-related Migration Questions, continued

| Question                     | Description and/or Default Value  |
|------------------------------|---|
|                              | to postgres.  |
| DB DBA user                  | The name of the administrator user inside the database cluster or server, which is usually set to postgres.     |
| DB DBA user password         | The password of the administrator user inside the database cluster or server, which is usually set to postgres. |
| Database opc_op password     | The password for the opc_op database user. The default is opc_op.   |
| Database opc_report password | The password for the opc_report database user. The default is opc_report.                                       |

After you answer all the questions, the `ovougrade` script checks the database configuration data and the summary of all provided answers appears.

2. Check the summary data, and then press **ENTER** to perform the database configuration.
3. Press **ENTER** to continue. The `ovougrade` script continues as follows:
  - Stops the Oracle database.
  - Uploads the configuration, history messages, and active messages to the PostgreSQL database.

At this point, the Administration UI is either installed (if you do not have it installed yet) or upgraded (if it is already installed). In the first case, you must answer the Administration UI-related questions described in [Table 7](#).

## Upgrading an HPOM Database

[Table 22](#) shows which database versions are supported with HPOM 9.2x.

Table 22: Supported Database Versions

| Oracle Database Versions        | PostgreSQL Database Versions |
|---------------------------------|------------------------------|
| • 11gR1 (11.1.0.7)              | • 9.1                        |
| • 11gR2 (11.2.0.1–11.2.0.4)     | • 9.2                        |
| • 12cR1 (12.1.0.1 and 12.1.0.2) | • 9.3                        |

### Supported Database Versions, continued

| Oracle Database Versions | PostgreSQL Database Versions                          |
|--------------------------|---|
|                          | <ul style="list-style-type: none"><li>• 9.4</li></ul> |

For detailed information about installing an Oracle database or a PostgreSQL database, see ["Installing an Oracle Database" on page 27](#) or ["Installing a PostgreSQL Database" on page 41](#).

## Upgrading an Oracle Database

Starting with Oracle 11.2, Oracle distributes patch sets as full installations. Although it is possible to install the update on top of the previous Oracle version and then migrate the data by using the Oracle tools, this is not recommended. Instead, use the “out-of-place upgrade” method where you install the new version in a new, separate ORACLE\_HOME directory, and then migrate the data from the old installation to the new installation.

To upgrade an Oracle database (for example, version 11.1 to version 11.2) by using the “out-of-place upgrade” method, follow these steps:

1. Download all configuration data by performing the following steps:
  - a. Create an empty download specification file:

```
mkdir /tmp/cfgdwn  
echo "*" ;" > /tmp/cfgdwn/download.dsf
```
  - b. Download the configuration:

```
/opt/0V/bin/OpC/opccfgdwn /tmp/cfgdwn/download.dsf /tmp/cfgdwn
```
2. *Optional:* Download all messages by following these steps:
  - a. Perform a history download:

```
/opt/0V/bin/OpC/opchstdwn -older 0s -file /tmp/history
```
  - b. Acknowledge all active messages:

```
/opt/0V/bin/OpC/opcack -u <user_for_all_msg_grps> -a -f
```
  - c. Perform a second history download:

```
/opt/0V/bin/OpC/opchstdwn -older 0s -file /tmp/active
```
3. Stop HP Operations management server processes by running the following command:

```
/opt/0V/bin/ovc -kill
```
4. Depending on whether you have a local database or a remote/independent database, choose one of the following procedures to stop the Oracle database:
  - *Local database:*

```
/sbin/init.d/ovoracle stop
```

- *Remote/independent database:* On the database server, follow these steps:
  - i. Switch to the `oracle` user:  
`su - oracle`
  - ii. Set the `ORACLE_HOME` environment variable so that it points to the location where the old Oracle database is installed:  
`export ORACLE_HOME=/opt/oracle/product/<old_version>`
  - iii. Set the `ORACLE_SID` environment variable. For example:  
`export ORACLE_SID=openview`
  - iv. Run the SQL\*Plus tool:  
`$ORACLE_HOME/bin/sqlplus /nolog`
  - v. Stop the Oracle database by running the following commands:  
`connect / as sysdba`  
`shutdown`  
`exit`
  - vi. Switch back to the `root` user:  
`exit`

5. *Recommended:* Back up the old Oracle home directories, data directories, and configuration files.
6. Remove the old Oracle database instance by running the following command:  
`/opt/OV/bin/OpC/opcdbsetup -d`
7. *Optional:* Remove the old Oracle installation. For detailed information, see the Oracle documentation.

**Note:** Depending on the HPOM environment, removing the old Oracle installation may include removing the Oracle server as well as the client and instant client products.

8. Install the new Oracle database version as described in ["Installing an Oracle Database" on page 27](#).

When installing the new Oracle database version, keep in mind the following:

- Because there might be a difference in required operating system versions, patches, and kernel parameters for different Oracle versions, make sure that your system meets the requirements stated in the Oracle documentation.
- The `.profile` file for the Oracle user or other configuration files (for example, `/etc/oratab`, listener configuration files, and so on) may contain one or more of the following Oracle configuration variables: `ORACLE_HOME`, `ORACLE_SID`, and `ORACLE_BASE`. If this is the case, it is important to update them to the new values before proceeding with the upgrade.

- You must obtain the updated 32-bit database client libraries so that Oracle can work properly with HPOM. For details, see ["Obtaining the libclntsh.so and libnnz11.so Libraries for Oracle Database 11g Release 2" on page 36](#) or ["Obtaining the libclntsh.so and libnnz12.so Libraries for Oracle Database 12c" on page 40](#).

9. Run the Oracle database setup tool (that is, `opcdbsetup`) and make sure to use the appropriate values for the new database version.

**Note:** The links from the HPOM library directory to the Oracle client libraries are updated and point to the new location. If this is not the case, you can recreate them either manually or by running the `/opt/OV/bin/OpC/opcdblink oracle` command.

10. Make sure that the new Oracle database is up and running. Depending on whether you have a local database or a remote/independent database, choose one of the following procedures to restart the Oracle database:

- *Local database:*

```
/sbin/init.d/ovoracle start
```

- *Remote/independent database:* On the database server, follow these steps:

- i. Switch to the `oracle` user:

```
su - oracle
```

- ii. Set the `ORACLE_HOME` environment variable so that it points to the location where the new Oracle database is installed:

```
export ORACLE_HOME=/opt/oracle/product/<new_version>
```

- iii. Set the `ORACLE_SID` environment variable. For example:

```
export ORACLE_SID=openview
```

- iv. Run the SQL\*Plus tool:

```
$ORACLE_HOME/bin/sqlplus /nolog
```

- v. Start the Oracle database by running the following commands:

```
connect / as sysdba
```

```
startup
```

```
exit
```

- vi. Switch back to the `root` user:

```
exit
```

11. Upload the configuration data by running the following command:

```
/opt/OV/bin/OpC/opccfgupld -replace /tmp/cfgdwn
```

12. If you downloaded all the messages, upload them by following these steps:



- a. Upload the active messages from your download:

```
/opt/0V/bin/OpC/opchistup1 /tmp/active
```

- b. Unacknowledge the active messages in the history message browser and disown them in the message browser by using the Java GUI.

For detailed information, see the *HPOM Java GUI Operator's Guide*.

- c. Upload the history messages:

```
/opt/0V/bin/OpC/opchistup1 /tmp/history
```

13. Restart HP Operations management server processes by running the following command:

```
/opt/0V/bin/ovc -start
```

## Upgrading a PostgreSQL Database

The methods for upgrading a PostgreSQL database differ depending on the PostgreSQL database version to which you want to upgrade. The PostgreSQL database version is represented either by the first two digits of a version number—the major PostgreSQL database version (for example, 9.1)—or the first three digits of a version number—the minor PostgreSQL database version (for example, 9.1.1).

Because minor PostgreSQL database versions are always compatible with earlier and later minor PostgreSQL database versions of the same major PostgreSQL database version, the upgrade procedure is simple and consists of replacing the executables while the management server is down and restarting the management server. In this case, the data directory remains unchanged. For details, see "[Upgrading a Minor PostgreSQL Database Version](#)" below.

When upgrading the major PostgreSQL database version, the contents of the data directory changes, which makes this method more complicated than the method for upgrading the minor PostgreSQL database version. For details, see "[Upgrading a Major PostgreSQL Database Version](#)" on page 171.

**Note:** Because there might be a difference in required operating system versions, patches, and kernel parameters for different PostgreSQL versions, make sure that your system meets the requirements stated in the PostgreSQL documentation before you start the upgrade procedure.

It is also recommended that you back up your system before upgrading the PostgreSQL database.

## Upgrading a Minor PostgreSQL Database Version

To upgrade a minor PostgreSQL database version (for example, version 9.1.1 to version 9.1.5), follow these steps:

1. Stop HP Operations management server processes by running the following command:

```
/opt/0V/bin/ovc -kill
```

2. Depending on whether you have a managed database or a remote/manual database, choose one of the following two commands to stop the PostgreSQL database:

- For a managed database:

```
/sbin/init.d/ovopsql stop current
```

- For a remote/manual database:

```
su - <OS_DBA_user>
```

```
<PostgreSQL_binary_directory>/pg_ctl -D <PostgreSQL_cluster_directory> stop
```

3. Install new PostgreSQL server binaries.

For details, see ["Installing PostgreSQL Server Binaries" on page 42](#).

**Note:** The new PostgreSQL server binaries may be installed at the same location as the old ones. If you have another PostgreSQL database cluster running on the old PostgreSQL server binaries, it is highly recommended that you temporarily stop them during the installation of the new PostgreSQL server binaries.

4. *If required:* Edit the binary or library paths in the following files:

```
/etc/opt/OV/share/conf/ovdbconf
```

```
<PostgreSQL_cluster_directory>/hpom.conf
```

5. Recreate the required links to the PostgreSQL database client libraries and binaries by running the following command:

```
/opt/OV/bin/OpC/opcdblink psql
```

**Note:** Make sure that `/opt/OV/lib/hpux32/PSQL` points to the correct location (that is, to the PostgreSQL library directory). If not, recreate the link manually.

6. Depending on whether you have a managed database or a remote/manual database, choose one of the following two commands to restart the PostgreSQL database:

- *For a managed database:*

```
/sbin/init.d/ovopsql start current
```

- *For a remote/manual database:*

```
su - <OS_DBA_user>
```

```
<PostgreSQL_binary_directory>/pg_ctl \
```

```
-D <PostgreSQL_cluster_directory> start -l logfile
```

7. Restart HP Operations management server processes by running the following command:

```
/opt/OV/bin/OpC/opcsv -start
```

## Upgrading a Major PostgreSQL Database Version

To upgrade a major PostgreSQL database version (for example, version 9.1 to version 9.2), follow these steps:

1. Download all configuration data by following these steps:
    - a. Create an empty download specification file:

```
mkdir /tmp/cfgdwn  
echo "*" ";" > /tmp/cfgdwn/download.dsf
```
    - b. Download the configuration:

```
/opt/OV/bin/OpC/opccfgdwn /tmp/cfgdwn/download.dsf /tmp/cfgdwn
```
  2. *Optional:* Download all messages by following these steps:
    - a. Perform a history download:

```
/opt/OV/bin/OpC/opchistdwn -older 0s -file /tmp/history
```
    - b. Acknowledge all active messages:

```
/opt/OV/bin/OpC/opcack -u <user_for_all_msg_grps> -a -f
```
    - c. Perform a second history download:

```
/opt/OV/bin/OpC/opchistdwn -older 0s -file /tmp/active
```
  3. Stop HP Operations management server processes by running the following command:

```
/opt/OV/bin/ovc -kill
```
  4. Depending on whether you have a managed database or a remote/manual database, choose one of the following two commands to stop the PostgreSQL database:
    - *For a managed database:*

```
/sbin/init.d/ovopsql stop current
```
    - *For a remote/manual database:*

```
su - <OS_DBA_user>  
<PostgreSQL_binary_directory>/pg_ctl -D <PostgreSQL_cluster_directory> stop
```
  5. Install new PostgreSQL server binaries.  
For details, see ["Installing PostgreSQL Server Binaries" on page 42](#).
  6. Create and configure a PostgreSQL database cluster as described in ["Creating and Configuring a PostgreSQL Database Cluster" on page 99](#).
- Caution:** The PostgreSQL database cluster must be created with new PostgreSQL server binaries.
7. *Recommended:* Back up old PostgreSQL database cluster directory and configuration files.

8. Remove the old PostgreSQL database cluster installation by choosing one of the following two methods:

- *Automatically:*

As the root user, run the following command:

```
/opt/OV/bin/OpC/psqlsetup remove
```

- *Manually:*

As the root user, follow these steps:

- i. Delete the old PostgreSQL database cluster directory:

```
rm -rf <old_cluster_directory>
```

- ii. Delete the HPOM database configuration file:

```
rm -f /etc/opt/OV/share/conf/ovdbconf
```

- iii. If the PostgreSQL database cluster is set to autostart, edit the `/etc/ovopsq1` configuration file, and then delete the old PostgreSQL database cluster directory within the configuration file.

9. Make sure that the new PostgreSQL database cluster is up and running. Depending on whether you have a managed database or a remote/manual database, choose one of the following two commands to restart the PostgreSQL database:

- *For a managed database:*

```
/sbin/init.d/ovopsq1 start current
```

- *For a remote/manual database:*

```
su - <OS_DBA_user>
```

```
<PostgreSQL_binary_directory>/pg_ctl \
```

```
-D <PostgreSQL_cluster_directory> start -l logfile
```

10. Run the PostgreSQL database setup tool (that is, `psqlsetup`) according to the new installation and configuration.

11. Upload the configuration data by running the following command:

```
/opt/OV/bin/OpC/opccfgup1d -replace /tmp/cfgdwn
```

12. If you downloaded all the messages, upload them by following these steps:

- a. Upload the active messages from your download:

```
/opt/OV/bin/OpC/opchistup1 /tmp/active
```

- b. Unacknowledge the active messages in the history message browser and disown them in the message browser by using the Java GUI.

For detailed information, see the *HPOM Java GUI Operator's Guide*.

- c. Upload the history messages:

```
/opt/OV/bin/OpC/opchistup1 /tmp/history
```

13. Restart HP Operations management server processes by running the following command:

```
/opt/OV/bin/ovc -start
```

## Preparing the Administration UI to Use the New HPOM Database

To prepare the Administration UI to use the new HPOM database, follow these steps:

1. Stop and clean the Administration UI by running the following commands:

```
/opt/OV/OMU/adminUI/adminui stop
```

```
/opt/OV/OMU/adminUI/adminui clean
```

2. *Oracle only:* Update the ORACLE\_HOME variable in the midas\_env.sh file.
3. Update the following configuration files with the appropriate JDBC connection string:

```
/opt/OV/OMU/adminUI/conf/ovoinstall.properties
```

```
/opt/OV/OMU/adminUI/conf/ovoconfig.properties
```

```
/opt/OV/OMU/adminUI/conf/opccfg.properties
```

```
/opt/OV/OMU/adminUI/conf/ovoappl.properties
```

Each of these configuration files contains a JDBC connection string that looks as follows:

- *Oracle:*

```
ovodb.url=jdbc:oracle:thin:@<SERVER>:<PORT>:<SID>
```

The connection string should be in one line, without line feeds and without blanks inside it.

**Note:** To obtain the correct Oracle JDBC connection string, check the \$ORACLE\_HOME/network/admin/tnsnames.ora file.

- *PostgreSQL:*

```
ovodb.url=jdbc:Postgresql://<PostgreSQL_host>:<port>/<DB_name>
```

For example:

```
ovodb.url=jdbc:Postgresql://avocado.hp.com:5433/openview
```

4. Start the Administration UI by running the following command:

```
/opt/OV/OMU/adminUI/adminui start
```

## Upgrading the Java GUI

To upgrade the Java GUI, follow these steps:

1. Deinstall any previous version of the Java GUI from the client system.

For detailed information about deinstalling the Java GUI, see ["Deinstalling the Java GUI" on page 131](#).

2. Install the new version of the Java GUI on the client system.

For details, see ["Installing the Java GUI" on page 67](#).

## Upgrading the HP Operations Agent Software

To upgrade the HP Operations agent software to a newer version, run the `inst.sh` script:

```
/opt/0V/bin/OpC/agtinstall/inst.sh
```

For detailed information about how to upgrade the HP Operations agent software automatically by using the installation script, see the *HPOM Administrator's Reference* and the *inst.sh(1M)* manual page.

## Migrating Licenses to HPOM 9.2x

When migrating from an existing HPOM system to another or upgrading an existing HPOM system, you can move license passwords from an HPOM 9.1x system to an HPOM 9.2x system. All HPOM 9.1x license passwords are compatible with HPOM 9.2x.

HPOM 9.2x license passwords are exchangeable between the HP-UX on HP Integrity, Sun Solaris, and Linux operating systems.

## Prerequisite for License Migration

The IP address on the source and target systems must be the same. Otherwise, the license passwords do not work on the target system and must be moved through the HP Password Delivery Center.

**Note:** It is possible to install license passwords from systems with a different IP address. However, this does not mean that they are valid on the target system. Validity is checked during runtime and license passwords without matching IP addresses are ignored.

## Migrating Licenses

To migrate license passwords from an HPOM 9.1x source system to an HPOM 9.2x target system, follow these steps:

1. Copy the license passwords from the source system to a safe place on the target system.

The license passwords are located in the following file:

```
/var/opt/OV/shared/server/OprEl/AutoPass/LicFile.txt
```

For example, to copy the file, run the following command:

```
scp /var/opt/OV/shared/server/OprEl/AutoPass/LicFile.txt \  
<target_sys>:<directory>/HPOM9-LicFile-Backup.txt
```

2. On the target system, install the license passwords selectively by using the AutoPass GUI (recommended) or nonselectively by using the `ovolicense` tool.

**Caution:** Make sure that you never copy the license passwords directly into the AutoPass license password file or overwrite the AutoPass license password file with another license password file, as this could result in license locks.

## Installing License Passwords Selectively

To install license passwords selectively by using the AutoPass GUI, follow these steps:

- a. On the HPOM 9.2x target system, run the following command to open the AutoPass GUI:  

```
ovolicense -gui -a HPOM
```
- b. In the GUI, select **Install License Key**, and then **Install/Restore License Key from file**.
- c. Click **Browse** to select the license file copied from the source system.
- d. Click **View file contents**.
- e. Select your license passwords from the list, and then click **Install**.

## Installing License Passwords Nonselectively

You can install license passwords nonselectively by using the `ovolicense` tool. On the HPOM 9.2x target system, call the `ovolicense` tool to import the license passwords from the backup file.

For example:

```
ovolicense -i -a HPOM -f <directory>/HPOM9-LicFile-Backup.txt
```

This imports all passwords from the specified files.

# Chapter 9: Managing HPOM in a Cluster Environment

## In This Chapter

This chapter describes how to do the following:

- Choose a configuration scenario for installing the HP Operations management server and the database server in a cluster environment.
- Upgrade HPOM in a cluster environment.
- Stop the HP Operations management server in a cluster environment for maintenance.
- Deinstall HPOM from cluster nodes.

For detailed information about the high availability terms, see the *HPOM Concepts Guide*.

For more information about the administration of the HP Operations management server in a cluster environment, see the *HPOM Administrator's Reference*.

## Configuration Scenarios

When installing an HP Operations management server and an Oracle database server or a PostgreSQL database server in a cluster environment, you can choose one of the following configuration scenarios:

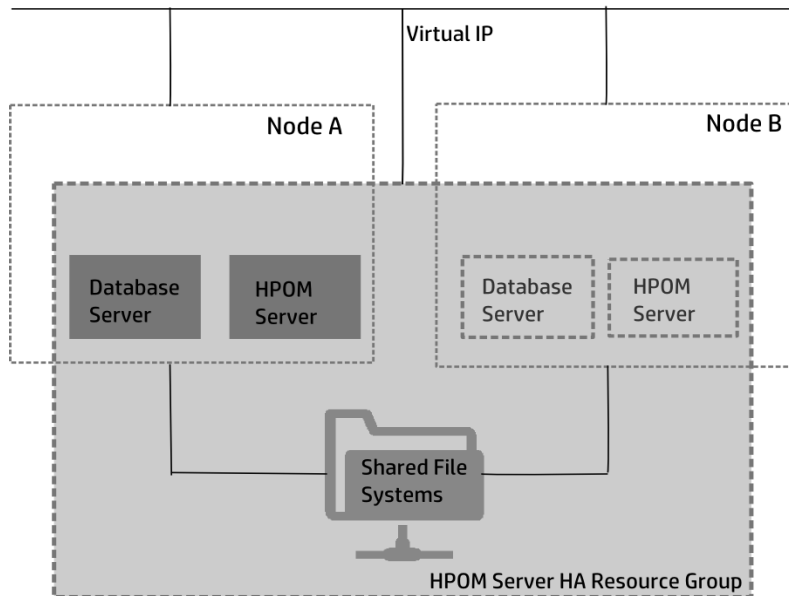
- **Basic management server configuration**

This is the simplest cluster configuration. You can use all backup and maintenance commands without restrictions.

The HP Operations management server and the database server are part of the same HA resource



group (HARG).

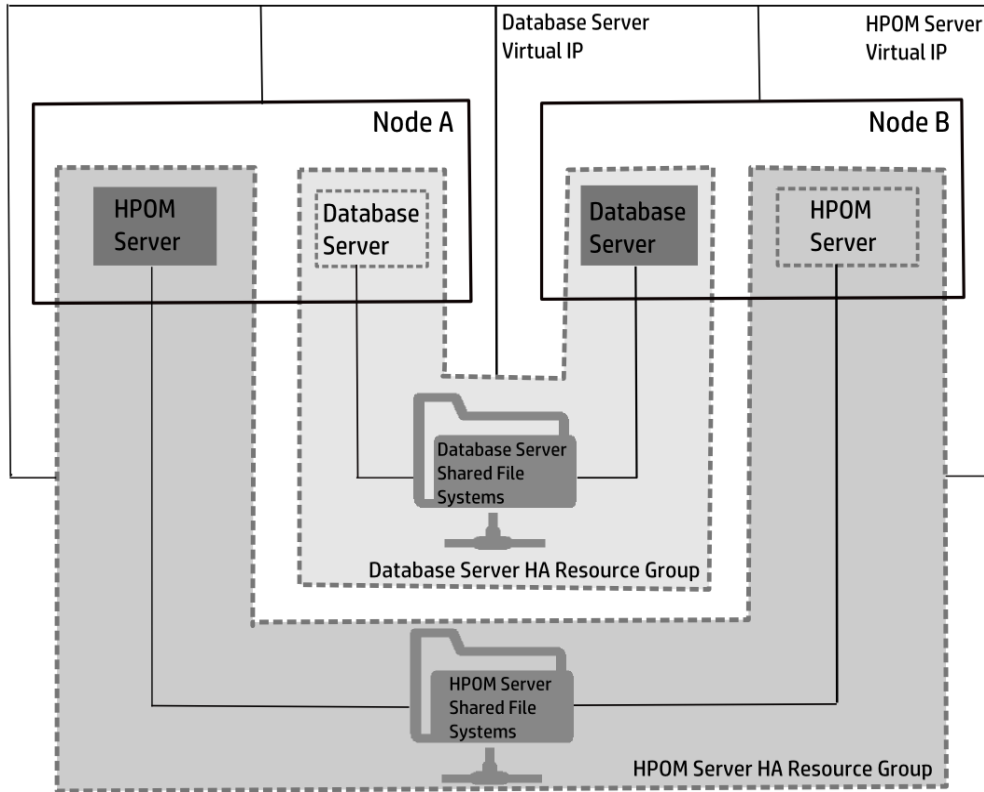


- **Decoupled management server configuration**

With this setup, you can use both physical nodes with the HPOM HARG running on one node and the database server resource group on the other node. The HP Operations management server and the database server are configured as separate HARGs by the HP Operations management server installation scripts. This configuration scenario is also known as 3Tier HP Operations management server configuration in a cluster environment.

The backup scripts are adapted to work even if the HPOM and database HARGs are running on different nodes. However, to restore a backup, the HPOM and database HARGs must run on the

same node.

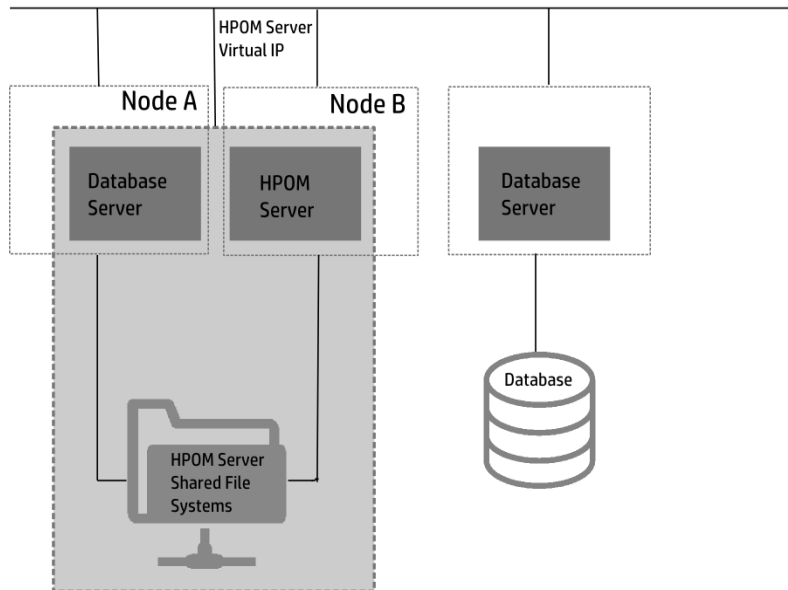


- **Independent database server configuration**

Following this scenario, you can use a remote database. The remote database should also run on a cluster. Otherwise the high availability of the HPOM setup is compromised. You may find this scenario useful if you already have a central database server cluster that you also want to use for the HPOM database. With this scenario, on the other hand, you cannot use the HPOM backup scripts.

In exceptional cases, the database server can be configured as an independent database server—install the database client on the cluster nodes that are hosting the HP Operations management server. You can install the independent database as a stand-alone server or as an HARG on an

independent cluster.



## Upgrading HPOM in a Cluster Environment

To upgrade the HP Operations management server running in a cluster environment to version 9.2x, you must first perform the upgrade procedure on the active cluster node, and then on all passive cluster nodes.

Depending on the HPOM version from which you upgrade, follow either the procedure described in ["Upgrading from HPOM 8.xx to HPOM 9.2x" on page 150](#) or ["Upgrading from HPOM 9.1x to HPOM 9.2x" on page 160](#).

## Stopping the HP Operations Management Server in a Cluster Environment for Maintenance

Sometimes, you need to stop the HP Operations management server to install a patch, perform an upgrade, conduct maintenance, and so on.

**Caution:** When stopping and starting the HP Operations management server, make sure not to use the cluster-related commands. Only the HPOM commands such as `ovc` and `opcsv` should be used.

To stop the HP Operations management server, follow these steps:

1. Disable HARG monitoring by running the command:  
`/opt/OV/sbin/ovharg -monitor ov-server disable`
2. Stop the HP Operations management server.

**Caution:** Before you run the `opcsv -stop`, `ovc -stop`, or `ovc -kill` command, you must disable HARG monitoring. Failing to do so results in a failover.

3. Perform the intended action (the patch installation, an upgrade, the maintenance, and so on).
4. Start the HP Operations management server.
5. Enable HARG monitoring by running the following command:  
`/opt/OV/sbin/ovharg -monitor ov-server enable`

**Note:** Before enabling HARG monitoring, make sure that the HP Operations management server is running.

## Deinstalling HPOM from Cluster Nodes

HPOM can be deinstalled in one of the following ways:

- **From all cluster nodes**

When deinstalling the HP Operations management server from a cluster environment, you must perform the deinstallation procedure in the following sequence:

- a. Deinstall the HP Operations management server from the passive cluster nodes. These are the systems that are installed and configured to run the HP Operations management server, but are not running currently.

For details, see ["Deinstalling HPOM from Passive Cluster Nodes" on the next page](#).

- b. When the HP Operations management server is deinstalled from all passive nodes, deinstall it from the active cluster node. This is the system on which the HP Operations management server is currently up and running as an HARG.

For details, see ["Deinstalling HPOM from the Active Cluster Node" on the next page](#).

- **From selected cluster nodes**

After you deinstall the HP Operations management server from a cluster node, this node is no longer able to run the HP Operations management server. The cluster environment running the HP Operations server will be reduced by one node.

To deinstall the HP Operations management server from a cluster node, this node must be in the passive state. For details on how to deinstall the HP Operations management server from passive cluster nodes, see ["Deinstalling HPOM from Passive Cluster Nodes" on the next page](#).

## Deinstalling HPOM from Passive Cluster Nodes

Before the HP Operations management server is deinstalled from a passive cluster node, the following requirements must be met:

- The HP Operations server `HARG ov-server` may not be active on this node.
- Virtual host may not be active.
- Shared file systems may not be mounted.

After ensuring that all these requirements are met, deinstall the HP Operations management server as described in ["Deinstalling HPOM" on page 129](#).

## Deinstalling HPOM from the Active Cluster Node

When the HP Operations management server is deinstalled from all the passive cluster nodes, you can start the deinstallation process from the node on which the HP Operations management server is running.

Deinstall the HP Operations management server from this node as described in ["Deinstalling HPOM" on page 129](#).

# Chapter 10: Installing HPOM in an HP ServiceGuard Environment

## In This Chapter

This chapter describes how to install and configure the HP Operations management server in an HP ServiceGuard environment. It also contains the information about installation requirements and log files.

For more information about managing HPOM in a cluster environment, see ["Managing HPOM in a Cluster Environment" on page 176](#).

## Installation Requirements

To run HPOM in an HP ServiceGuard environment, your system must meet the following requirements:

- HP-UX 11i v3 on HP Integrity
- HP ServiceGuard 11.20

**Caution:** Make sure that the HP Operations agent version is 11.04.016 or higher.

For additional requirements about installing HPOM, see ["Installation Requirements for the Management Server" on page 13](#).

## Installing and Configuring the HP Operations Management Server in a Cluster Environment

To install and configure the HP Operations management server in a cluster environment, you must complete the following tasks:

- **On the first cluster node:**
  - Task 1: ["Before You Install the HP Operations Management Server on the First Cluster Node" on the next page](#)
  - Task 2: ["Installing a Database Server for HPOM in a Cluster Environment" on page 194](#)

- Task 3: ["Installing and Configuring the HP Operations Management Server on Cluster Nodes" on page 200](#)
- **On each additional cluster node:**
  - Task 1: ["Before You Install the HP Operations Management Server on Additional Cluster Nodes" on page 193](#)
  - Task 2: ["Installing a Database Server for HPOM in a Cluster Environment" on page 194](#)
  - Task 3: ["Installing and Configuring the HP Operations Management Server on Cluster Nodes" on page 200](#)

**Caution:** You cannot install HPOM simultaneously on all cluster nodes. When the installation process is completed on one cluster node, begin the installation on the next node, until HPOM is installed on all the nodes in a cluster environment.

## Before You Install the HP Operations Management Server on the First Cluster Node

Before you install the HP Operations management server on the first cluster node, you must perform appropriate preparation procedures depending on the cluster environment you want to configure.

For detailed information about configuration scenarios, see ["Configuration Scenarios" on page 176](#).

Depending on the configuration scenario you choose, see one of the following sections:

- *Basic environment:* ["Preparation Steps for the First Cluster Node in a Basic Environment" below](#)
- *Decoupled environment:* ["Preparation Steps for the First Cluster Node in a Decoupled Environment" on page 187](#)
- *Independent database server:* ["Preparation Steps for the First Cluster Node in a Cluster Environment Using an Independent Database Server" on page 191](#)

## Preparation Steps for the First Cluster Node in a Basic Environment

Before you install the HP Operations management server in a cluster environment, follow these steps:

1. Depending on the Volume Manager that you use, define the following:  
*If you are using LVM:*

- a. Define the `ov_vg` volume group consisting of at least one shared disk for the HARG.

**Caution:** When defining a volume group or any of the volumes within the volume group, you can specify an optional name.

Make sure you do not use the MINUS SIGN (-) sign in the volume group and the logical volume names.

- b. Define the following volumes within the `ov_vg` volume group:

- o `ov_volume_etc`
- o `ov_volume_var`
- o `ov_volume_lcore`
- o `ov_volume_db_data`
- o *If the database index directory is on a different volume than the main data directory:* `ov_volume_db_index`
- o *If the PostgreSQL database table data directory is on a different volume than the main cluster directory:* `ov_volume_db_tables`
- o *If you choose to install Oracle database server binaries on a shared disk:* `ov_volume_db_core`

*If you are using Veritas Volume Manager:*

- a. Define the `ov_dg` disk device group consisting of at least one shared disk for the HARG.

- b. Define the following volumes within the `ov_dg` disk device group:

- o `ov_volume_etc`
- o `ov_volume_var`
- o `ov_volume_lcore`
- o `ov_volume_db_data`
- o *If the database index directory is on a different volume than the main data directory:* `ov_volume_db_index`
- o *If the PostgreSQL database table data directory is on a different volume than the main cluster directory:* `ov_volume_db_tables`
- o *If you choose to install Oracle database server binaries on a shared disk:* `ov_volume_db_core`

**Caution:** When defining a disk device group or any of the volumes within the disk device group, you can specify an optional name.

Make sure you do not use the MINUS SIGN (-) sign in the disk device group names and in the names of the volumes within the disk device group.



2. Make sure that the following shared file systems are available:

- /etc/opt/0V/share
- /var/opt/0V/share
- /var/opt/0V/shared/server
- HP Operations management server database

**Note:** *Oracle only:* You may select an alternative mount point. The default is the following:

`/u01/oradata/<ORACLE_SID>`

In this instance, `<ORACLE_SID>` is the value of the `ORACLE_SID` variable used for the configuration of the HP Operations management server database. It is usually set to `openview`.

- *If the database index directory is on a different volume than the main data directory:* HP Operations management server database index files
- *If the PostgreSQL database table data directory is on a different volume than the main cluster directory:* PostgreSQL database table data files
- *If you choose to install Oracle database server binaries on a shared disk:* Oracle database server binaries (equal to the value of the `ORACLE_BASE` variable)

Table 23: Disk Space for Shared File Systems

| Shared File System   | Recommended         |
|--|---------------------|
| /etc/opt/0V/share  | 2 GB                |
| /var/opt/0V/share  | 2.5 GB <sup>a</sup> |
| /var/opt/0V/shared/server                                    | 2.5 GB              |
| Database data directory                                      | 2 GB <sup>b</sup>   |
| Database index directory ( <i>optional</i> )                 | 100 MB <sup>b</sup> |
| PostgreSQL database table data directory ( <i>optional</i> ) | 2 GB                |
| Oracle database server binaries ( <i>optional</i> )          | 10 GB               |

<sup>a</sup>Further disk space will be required when SPIs are installed.

<sup>b</sup>For small-sized to medium-sized installations. Larger installations and high numbers of messages will result in greater space requirements.

3. Prepare mount points for the shared file systems listed in the previous step.
4. If you are using Veritas Volume Manager, import the `ov_dg` disk device group on the current node by running the following command:

```
/usr/sbin/vxdg import ov_dg
```

5. Depending on the Volume Manager that you use, start the `ov_vg` or `ov_dg` volume group by running the following command:

- *If you are using LVM:*

```
/usr/sbin/vgchange -a e ov_vg
```

- *If you are using Veritas Volume Manager:*

```
/usr/sbin/vxvol -g ov_dg startall
```

6. Mount the shared file systems on the prepared mount points as follows:

*If you are using LVM:*

a. `/usr/sbin/mount -F <FSType> /dev/ov_vg/ov_volume_var /var/opt/OV/share`

b. `/usr/sbin/mount -F <FSType> /dev/ov_vg/ov_volume_etc /etc/opt/OV/share`

c. `/usr/sbin/mount -F <FSType> /dev/ov_vg/ov_volume_lcore \  
/var/opt/OV/shared/server`

d. `/usr/sbin/mount -F <FSType> /dev/ov_vg/ov_volume_db_data \  
<database_mount_point>`

- e. *Optional:* If the database index directory is on a different volume than the main data directory:

```
/usr/sbin/mount -F <FSType> /dev/ov_vg/ov_volume_db_index \  
<database_index_mount_point>
```

- f. *Optional:* If the PostgreSQL database table data directory is on a different volume than the main cluster directory:

```
/usr/sbin/mount -F <FSType> /dev/ov_vg/ov_volume_db_tables \  
<postgres_table_data_mount_point>
```

- g. *Optional:* If you choose to install Oracle database server binaries on a shared disk:

```
/usr/sbin/mount -F <FSType> /dev/ov_vg/ov_volume_db_core \  
<oracle_binaries_mount_point>
```

*If you are using Veritas Volume Manager:*

a. `/usr/sbin/mount -F <FSType> /dev/vx/dsk/ov_dg/ov_volume_etc \  
/etc/opt/OV/share`

b. `/usr/sbin/mount -F <FSType> /dev/vx/dsk/ov_dg/ov_volume_var \  
/var/opt/OV/share`

c. `/usr/sbin/mount -F <FSType> /dev/vx/dsk/ov_dg/ov_volume_lcore \  
/var/opt/OV/shared/server`

d. `/usr/sbin/mount -F <FSType> /dev/vx/dsk/ov_dg/ov_volume_db_data \  
<database_mount_point>`

- e. *Optional:* If the database index directory is on a different volume than the main data directory:

```
/usr/sbin/mount -F <FSType> /dev/vx/dsk/ov_dg/ov_volume_db_index \  
<database_index_mount_point>
```

- f. *Optional:* If the PostgreSQL database table data directory is on a different volume than the main cluster directory:

```
/usr/sbin/mount -F <FSType> /dev/vx/dsk/ov_dg/ov_volume_db_tables \  
<postgres_table_data_mount_point>
```

- g. *Optional:* If you choose to install Oracle database server binaries on a shared disk:

```
/usr/sbin/mount -F <FSType> /dev/vx/dsk/ov_dg/ov_volume_db_core \  
<oracle_binaries_mount_point>
```

7. Activate the HP Operations management server virtual network IP:

```
/usr/sbin/cmmmodnet -a -i <IP> <subnet>
```

In this instance, <IP> is the IP address of the virtual host that you previously selected and <subnet> is the subnet address of the virtual host you previously selected.

## Preparation Steps for the First Cluster Node in a Decoupled Environment

Before you install the HP Operations management server in a cluster environment, follow these steps:

1. Depending on the Volume Manager that you use, define the following:

*If you are using LVM:*

- a. Define the `ov_vg` volume group consisting of at least one shared disk for the HARG.
- b. Define the following volumes within the `ov_vg` volume group:
  - o `ov_volume_etc`
  - o `ov_volume_var`
  - o `ov_volume_lcore`
- c. Define the `ov_db_vg` volume group consisting of at least one shared disk for the HARG.
- d. Define the following volumes within the `ov_db_vg` volume group:
  - o `ov_volume_db_data`
  - o *If the database index directory is on a different volume than the main data directory:* `ov_volume_db_index`
  - o *If the PostgreSQL database table data directory is on a different volume than the main cluster directory:* `ov_volume_db_tables`
  - o *If you choose to install Oracle database server binaries on a shared disk:* `ov_volume_db_core`

**Caution:** When defining a volume group or any of the volumes within the volume group, you can specify an optional name.

Make sure you do not use the MINUS SIGN (-) sign in the volume group and the logical volume names.

*If you are using Veritas Volume Manager:*

- a. Define the `ov_dg` disk device group consisting of at least one shared disk for the HARG.
- b. Define the following volumes within the `ov_dg` disk device group:
  - o `ov_volume_etc`
  - o `ov_volume_var`
  - o `ov_volume_lcore`
- c. Define the `ov_db_dg` disk device group consisting of at least one shared disk for the HARG.
- d. Define the following volumes within the `ov_db_dg` disk device group:
  - o `ov_volume_db_data`
  - o *If the database index directory is on a different volume than the main data directory:* `ov_volume_db_index`
  - o *If the PostgreSQL database table data directory is on a different volume than the main cluster directory:* `ov_volume_db_tables`
  - o *If you choose to install Oracle database server binaries on a shared disk:* `ov_volume_db_core`

**Caution:** When defining a disk device group or any of the volumes within the disk device group, you can specify an optional name.

Make sure you do not use the MINUS SIGN (-) sign in the disk device group names and in the names of the volumes within the disk device group.

2. Make sure that the following shared file systems are available:

- `/etc/opt/OV/share`
- `/var/opt/OV/share`
- `/var/opt/OV/shared/server`
- HP Operations management server database

**Note:** *Oracle only:* You may select an alternative mount point. The default is the following:

`/u01/oradata/<ORACLE_SID>`

In this instance, <ORACLE\_SID> is the value of the ORACLE\_SID variable used for the configuration of the HP Operations management server database. It is usually set to openview.

- *If the database index directory is on a different volume than the main data directory:* HP Operations management server database index files
- *If the PostgreSQL database table data directory is on a different volume than the main cluster directory:* PostgreSQL database table data files
- *If you choose to install Oracle database server binaries on a shared disk:* Oracle database server binaries (equal to the value of the ORACLE\_BASE variable)

Table 24: Disk Space for Shared File Systems

| Shared File System                                  | Recommended         |
|---|---------------------|
| /etc/opt/OV/share                                   | 2 GB                |
| /var/opt/OV/share                                   | 2.5 GB <sup>a</sup> |
| /var/opt/OV/shared/server                           | 2.5 GB              |
| Database data directory                             | 2 GB <sup>b</sup>   |
| Database index directory (optional)                 | 100 MB <sup>b</sup> |
| PostgreSQL database table data directory (optional) | 2 GB                |
| Oracle database server binaries (optional)          | 10 GB               |

3. Prepare mount points for the shared file systems listed in the previous step.
4. If you are using Veritas Volume Manager, import the ov\_dg and ov\_db\_dg disk device groups on the current node by running the following commands:
 

```
/usr/sbin/vxdg import ov_dg
/usr/sbin/vxdg import ov_db_dg
```
5. Depending on the Volume Manager that you use, start the ov\_vg and ov\_db\_vg or ov\_dg and ov\_db\_dg volume groups by running the following commands:
  - *If you are using LVM:*

```
/usr/sbin/vgchange -a e ov_vg
```

<sup>a</sup>Further disk space will be required when SPIs are installed.

<sup>b</sup>For small-sized to medium-sized installations. Larger installations and high numbers of messages will result in greater space requirements.

```
/usr/sbin/vgchange -a e ov_db_vg
```

- *If you are using Veritas Volume Manager:*

```
/usr/sbin/vxvol -g ov_dg startall
```

```
/usr/sbin/vxvol -g ov_db_dg startall
```

6. Mount the shared file systems on the prepared mount points as follows:

*If you are using LVM:*

a. `/usr/sbin/mount -F <FSType> /dev/ov_vg/ov_volume_var /var/opt/OV/share`

b. `/usr/sbin/mount -F <FSType> /dev/ov_vg/ov_volume_etc /etc/opt/OV/share`

c. `/usr/sbin/mount -F <FSType> /dev/ov_vg/ov_volume_lcore \  
/var/opt/OV/shared/server`

d. `/usr/sbin/mount -F <FSType> /dev/ov_db_vg/ov_volume_db_data \  
<database_mount_point>`

- e. *Optional:* If the database index directory is on a different volume than the main data directory:

```
/usr/sbin/mount -F <FSType> /dev/ov_db_vg/ov_volume_db_index \  
<database_index_mount_point>
```

- f. *Optional:* If the PostgreSQL database table data directory is on a different volume than the main cluster directory:

```
/usr/sbin/mount -F <FSType> /dev/ov_vg/ov_volume_db_tables \  
<postgres_table_data_mount_point>
```

- g. *Optional:* If you choose to install Oracle database server binaries on a shared disk:

```
/usr/sbin/mount -F <FSType> /dev/ov_db_vg/ov_volume_db_core \  
<oracle_binaries_mount_point>
```

*If you are using Veritas Volume Manager:*

a. `/usr/sbin/mount -F <FSType> /dev/vx/dsk/ov_dg/ov_volume_etc \  
/etc/opt/OV/share`

b. `/usr/sbin/mount -F <FSType> /dev/vx/dsk/ov_dg/ov_volume_var \  
/var/opt/OV/share`

c. `/usr/sbin/mount -F <FSType> /dev/vx/dsk/ov_dg/ov_volume_lcore \  
/var/opt/OV/shared/server`

d. `/usr/sbin/mount -F <FSType> /dev/vx/dsk/ov_db_dg/ov_volume_db_data \  
<database_mount_point>`

- e. *Optional:* If the database index directory is on a different volume than the main data directory:

```
/usr/sbin/mount -F <FSType> /dev/vx/dsk/ov_db_dg/ov_volume_db_index \  
<database_index_mount_point>
```

- f. *Optional:* If the PostgreSQL database table data directory is on a different volume than the main cluster directory:

```
/usr/sbin/mount -F <FSType> /dev/vx/dsk/ov_dg/ov_volume_db_tables \  
<postgres_table_data_mount_point>
```

- g. *Optional:* If you choose to install Oracle database server binaries on a shared disk:

```
/usr/sbin/mount -F <FSType> /dev/vx/dsk/ov_db_dg/ov_volume_db_core \  
<oracle_binaries_mount_point>
```

7. Activate the HP Operations management server virtual network IP:

```
/usr/sbin/cmmmodnet -a -i <IP> <subnet>
```

In this instance, <IP> is the IP address of the virtual host that you previously selected and <subnet> is the subnet address of the virtual host you previously selected.

8. Activate the database virtual network IP:

```
/usr/sbin/cmmmodnet -a -i <IP> <subnet>
```

In this instance, <IP> is the IP address of the virtual host that you previously selected and <subnet> is the subnet address of the virtual host you previously selected.

## Preparation Steps for the First Cluster Node in a Cluster Environment Using an Independent Database Server

Before you install the HP Operations management server in a cluster environment, follow these steps:

1. Depending on the Volume Manager that you use, define the following:

*If you are using LVM:*

- a. Define the `ov_vg` volume group consisting of at least one shared disk for the HARG.

**Caution:** When defining a volume group or any of the volumes within the volume group, you can specify an optional name.

Make sure you do not use the MINUS SIGN (-) sign in the volume group and the logical volume names.

- b. Define the following volumes within the `ov_vg` volume group:

- o `ov_volume_etc`
- o `ov_volume_var`
- o `ov_volume_lcore`

*If you are using Veritas Volume Manager:*

- a. Define the `ov_dg` disk device group consisting of at least one shared disk for the HARG.

- b. Define the following volumes within the `ov_dg` disk device group:

- o `ov_volume_etc`

- o `ov_volume_var`
- o `ov_volume_lcore`

**Caution:** When defining a disk device group or any of the volumes within the disk device group, you can specify an optional name.

Make sure you do not use the MINUS SIGN (-) sign in the disk device group names and in the names of the volumes within the disk device group.

2. Make sure that the following shared file systems are available:

- `/etc/opt/OV/share`
- `/var/opt/OV/share`
- `/var/opt/OV/shared/server`

Table 25: Disk Space for Shared File Systems

| Shared File System                     | Recommended         |
|--|---------------------|
| <code>/etc/opt/OV/share</code>         | 2 GB                |
| <code>/var/opt/OV/share</code>         | 2.5 GB <sup>a</sup> |
| <code>/var/opt/OV/shared/server</code> | 2.5 GB              |

3. Prepare mount points for the shared file systems listed in the previous step.
4. If you are using Veritas Volume Manager, import the `ov_dg` disk device group on the current node by entering the following command:

```
/usr/sbin/vxdg import ov_dg
```

5. Depending on the Volume Manager that you use, start the `ov_vg` or `ov_dg` volume group by running the following command:

- *If you are using LVM:*  

```
/usr/sbin/vgchange -a e ov_vg
```
- *If you are using Veritas Volume Manager:*  

```
/usr/sbin/vxvol -g ov_dg startall
```

6. Mount the shared file systems on the prepared mount points as follows:

*If you are using LVM:*

<sup>a</sup>Further disk space will be required when SPIs are installed.



- a. `/usr/sbin/mount -F <FSType> /dev/ov_vg/ov_volume_var /var/opt/OV/share`
- b. `/usr/sbin/mount -F <FSType> /dev/ov_vg/ov_volume_etc /etc/opt/OV/share`
- c. `/usr/sbin/mount -F <FSType> /dev/ov_vg/ov_volume_lcore \  
/var/opt/OV/shared/server`

*If you are using Veritas Volume Manager:*

- a. `/usr/sbin/mount -F <FSType> /dev/vx/dsk/ov_dg/ov_volume_etc \  
/etc/opt/OV/share`
- b. `/usr/sbin/mount -F <FSType> /dev/vx/dsk/ov_dg/ov_volume_var \  
/var/opt/OV/share`
- c. `/usr/sbin/mount -F <FSType> /dev/vx/dsk/ov_dg/ov_volume_lcore \  
/var/opt/OV/shared/server`

7. Activate the HP Operations management server virtual network IP:

```
/usr/sbin/cmmmodnet -a -i <IP> <subnet>
```

In this instance, *<IP>* is the IP address of the virtual host that you previously selected and *<subnet>* is the subnet address of the virtual host you previously selected.

## Before You Install the HP Operations Management Server on Additional Cluster Nodes

Before you install the HP Operations management server on additional cluster nodes, you must perform appropriate preparation procedures. The preparation steps are identical for all HP Operations management server installation scenarios.

### Preparation Steps for Additional Cluster Nodes

The following preconditions must be met before installing the HP Operations management server on an additional cluster node:

- The HP Operations management server must already be installed and running on one of the cluster nodes. This enables you to add a local node to the HP Operations management server configuration, and install and start the HP Operations agent software on the local node.
- On the node where HPOM is running, enable the remote shell connection for the `root` user to the node where you plan to install the HP Operations management server. You can do this by adding the following line into the `/.rhosts` file:

```
<node> root
```

You can check if the remote shell is enabled by running the following command:

```
remsh <active_node> -l root -n ls
```

A list of the files on the `root` directory from the node where the HP Operations management server is running should be displayed.

In more secure environments, you can set up a secure shell (SSH) connection between the node where you plan to install an HP Operations management server and the node where the HP Operations management server is running.

For the HP Operations management server installation, you must enable SSH access without password, for the `root` user between these two nodes. During the installation, the `ssh` and `scp` commands are used. Therefore, both commands must be accessible from the main path.

You can check if the secure remote shell is enabled by running the following command:

```
ssh <active_node> -l root -n ls
```

The type of connection is detected automatically. A secure connection has a higher priority if both types of connection are enabled.

- Shared file systems may not be mounted on this cluster node. They are already mounted on the cluster node where the HP Operations management server is running.
- Virtual IP may not be activated on this node because it is already used on the node where the HP Operations management server is running.

## Installing a Database Server for HPOM in a Cluster Environment

Before installing a database server for HPOM in a cluster environment, consider the following:

- *If you use the Oracle database:*

The Oracle database server binaries must be installed on a local disk to enable the high availability of the Oracle database server and consequently of the HP Operations management server. If the Oracle database server binaries become corrupt, it is very important that the Oracle database server can be switched to another cluster node with intact Oracle database server binaries.

In exceptional cases, you may want to install the Oracle database server binaries on a shared disk. This way only one set of Oracle database server binaries is installed but there is a greater risk of losing Oracle availability. If you choose the decoupled scenario for installing HPOM, a separate Oracle client installation is also needed.

- *If you use the PostgreSQL database:*

The PostgreSQL database server binaries must be installed locally on all nodes. The installation path must be the same on all cluster nodes.

[Table 26](#) shows which procedure to follow depending on the configuration scenario you choose.

Table 26: Configuration Scenarios Based on the File System Location

|                    | Database server location                                     |  |   |
|--------------------|--|--|---|
|                    | Local File System  | Shared File System (Exceptional)   | Remote File System                                      |
| <b>Basic</b>       | "Basic Management Server Configuration" below                | <ul style="list-style-type: none"> <li>• <i>Oracle</i>: "Basic Management Server Configuration" on page 197</li> <li>• <i>PostgreSQL</i>: "Basic Management Server Configuration" on page 198</li> </ul>         |   |
| <b>Decoupled</b>   | "Decoupled Management Server Configuration" below            | <ul style="list-style-type: none"> <li>• <i>Oracle</i>: "Decoupled Management Server Configuration" on page 197</li> <li>• <i>PostgreSQL</i>: "Decoupled Management Server Configuration" on page 198</li> </ul> |   |
| <b>Independent</b> | "Independent Database Server Configuration" on the next page |  | "Independent Database Server Configuration" on page 199 |

## Database Server on a Local Disk

### Basic Management Server Configuration

Depending on which database you want to install, follow the procedure described in "[Installing an Oracle Database](#)" on page 27 or "[Installing a PostgreSQL Database](#)" on page 41.

### Decoupled Management Server Configuration

Depending on which database you want to install, follow the procedure described in "[Installing an Oracle Database](#)" on page 27 or "[Installing a PostgreSQL Database](#)" on page 41.

## Independent Database Server Configuration

- *First cluster node*

Depending on which database you want to install, follow the procedure described in "[Installing an Oracle Database](#)" on page 27 or "[Installing a PostgreSQL Database](#)" on page 41.

- *Additional cluster node*

Depending on your database type, install either the Oracle Net Services and the Oracle client or the PostgreSQL client on the local disk. All other database configuration steps are performed by the HP Operations management server installation script.

**Note:** After the database server installation, on all HP Operations management server cluster nodes, create a script or a binary so that the HP Operations management server can determine the status of the database:

```
/opt/OV/bin/OpC/utlils/ha/ha_check_db
```

The exit code of this script or binary must be 0 if the database server runs, or other than 0 if it does not run.

*PostgreSQL only:* You can determine if the PostgreSQL server is up and running by checking if the `<cluster_dir>/postmaster.pid` file exists.

When the following questions appear during the independent database server configuration, make sure that you answer as follows:

| Question  | Answer   |
|---|----------|
| Separate Database from Server?  | <b>y</b> |
| Configure Server and Database running as separate HA resource groups?   | <b>n</b> |
| <i>Oracle only:</i> Set up the database manually (local/remote)?        | <b>y</b> |
| <i>Oracle only:</i> Is the manually configured database already set up? | <b>n</b> |

## Database Server on a Shared Disk (Exceptional)

Depending on your database type, see one of the following sections:

- "[Oracle Database Server on a Shared Disk](#)" on the next page
- "[PostgreSQL Database Server on a Shared Disk](#)" on page 198

## Oracle Database Server on a Shared Disk

The installation script automatically detects if Oracle database server binaries are located on a shared disk, or if the ORACLE\_BASE directory is a mount point for an external file system containing the Oracle database server binaries (the file system must always be mounted on the ORACLE\_BASE mount point).

## Basic Management Server Configuration

Install an Oracle database as described in ["Installing an Oracle Database" on page 27](#).

## Decoupled Management Server Configuration

When the Oracle database is separated from the HP Operations management server and Oracle database server binaries are installed on a shared disk, install the Oracle client on the local disk, so that the HP Operations management server can connect to the Oracle database server through the Oracle client. You must install the Oracle client on a location other than ORACLE\_BASE. The path to the client must be the same on all HP Operations management server cluster nodes.

- *First cluster node*

Install the Oracle client on the local disk, and then the Oracle server on the shared disk as described in ["Installing an Oracle Database" on page 27](#). Do not use the Instant Client, but the full Oracle Client (the Runtime installation type). Make sure that you use the 32-bit version of the client.

**Note:** When installing and configuring the HP Operations management server, the ORACLE\_BASE and ORACLE\_HOME variables must be set to the Oracle database server location.

### Enabling Database Network Connectivity

After installing the HP Operations management server, follow these steps:

- a. Copy the following configuration files from the Oracle database server location on the shared disk (`<Oracle_server_home>/network/admin/`) to the Oracle client location on the local disk (`<Oracle_client_home>/network/admin/`):
  - o listener.ora
  - o sqlnet.ora
  - o tnsnames.ora
  - o tnsnav.ora
- b. To contain the location of the Oracle client software, modify the ORACLE\_HOME variable at the following location:  
`/etc/opt/OV/share/conf/ovdbconf`
- c. Stop the HP Operations management server as an HARG by running the following command:

```
/opt/OV/bin/ovharg_config ov-server -stop <Local_hostname>
```

- d. Add the following lines to the `/etc/rc.config.d/ovoracle` file:

```
ORACLE_HOME=<Oracle_Server_Home>
ORACLE_SID=<ORACLE_SID>
export ORACLE_HOME ORACLE_SID
```

The `/etc/rc.config.d/ovoracle` file is used as a configuration file by the `/sbin/init.d/ovoracle` script, which is used by the Oracle HARG to start the Oracle database.

**Note:** Make sure that you use the latest version of the `/sbin/init.d/ovoracle` script. Copy the file from `newconfig` by running the following command:

```
cp /opt/OV/newconfig/OpC/sbin/init.d/ovoracle /sbin/init.d/ovoracle
```

- e. Remove the existing Oracle client library links from the `/opt/OV/lib` directory and replace them with the following ones:

```
ln -sf <ORACLE_HOME>/lib32/libcIntsh.so /opt/OV/lib/hpux32/libcIntsh.so
ln -sf <ORACLE_HOME>/lib32/libcIntsh.so /opt/OV/lib/hpux32/libcIntsh.so.11.1
ln -sf <ORACLE_HOME>/lib32/libnnz11.so /opt/OV/lib/hpux32/libnnz11.so
ln -sf <ORACLE_HOME>/lib32/libnnz12.so /opt/OV/lib/hpux32/libnnz12.so
```

- f. Start the HP Operations management server as an HARG by running the following command:

```
/opt/OV/bin/ovharg_config ov-server -start <Local_hostname>
```

The HP Operations management server will now connect to the Oracle database server through the Oracle client.

- *Additional cluster node*

Install the Oracle client on the local disk. All other database configuration steps are performed by the HP Operations management server installation script.

**Note:** When installing and configuring the HP Operations management server, the `ORACLE_HOME` variable must be set to the Oracle client location.

## PostgreSQL Database Server on a Shared Disk

### Basic Management Server Configuration

Install a PostgreSQL database as described in "[Installing a PostgreSQL Database](#)" on page 41.

### Decoupled Management Server Configuration

On all cluster nodes, install the PostgreSQL client and server on the local disk as described in "[Installing a PostgreSQL Database](#)" on page 41. All other database configuration steps are performed

by the HP Operations management server installation script.

## Database Server on a Remote File System

### Independent Database Server Configuration

- *First cluster node*

Depending on your database type, configure the database as described in "[Setting Up HPOM with a Remote/Manual Oracle Database](#)" on page 86 or "[Setting Up HPOM with a Remote/Manual PostgreSQL Database](#)" on page 98.

- *Additional cluster node*

Depending on your database type, install either the Oracle Net Services and the Oracle client or the PostgreSQL client on the local disk. All other database configuration steps are performed by the HP Operations management server installation script.

**Note:** After the database server installation, on all HP Operations management server cluster nodes, create a script or a binary so that the HP Operations management server can determine the status of the database:

```
/opt/0V/bin/OpC/Utils/ha/ha_check_db
```

The exit code of this script or binary must be 0 if the database server runs, or other than 0 if it does not run.

*PostgreSQL only:* You can determine if the PostgreSQL server is up and running by checking if the `<cluster_dir>/postmaster.pid` file exists.

When the following questions appear during the independent database server configuration, make sure that you answer as follows:

| Question  | Answer |
|---|--------|
| Separate Database from Server?  | y      |
| Configure Server and Database running as separate HA resource groups?   | n      |
| <i>Oracle only:</i> Set up the database manually (local/remote)?        | y      |
| <i>Oracle only:</i> Is the manually configured database already set up? | n      |

# Installing and Configuring the HP Operations Management Server on Cluster Nodes

When installing HPOM in a cluster environment, you must answer some questions and specify some values differently than in the stand-alone HPOM installation. These cluster-specific questions differ depending on whether you are installing and configuring the HP Operations management server on the first cluster node or on an additional cluster node.

**Caution:** Make sure that cluster node names are the same as hostnames. Otherwise, the configuration fails.

## Installing and Configuring the HP Operations Management Server on the First Cluster Node

To install and configure the HP Operations management server on the first cluster node, follow these steps:

1. After the `ovoconfigure` script detects a special environment, provide answers to the following cluster-specific questions:

| Question   | Instruction   |
|--|---|
| Run HPOM Server as an HA resource group                  | Press <b>y</b> followed by <b>ENTER</b> .<br>The script checks the remote shell connection and the secure remote shell connection.  |
| Would you prefer to use REMSH even though SSH is enabled | Press <b>ENTER</b> to accept the default answer (that is, n).   |
| HA Resource Group name                                   | Press <b>ENTER</b> to accept the default answer (that is, <code>ov-server</code> ), or specify an alternative name for the HARG, and then press <b>ENTER</b> .<br>HARGs are created during the installation of HPOM. The <code>ovinstall</code> script builds the package or the service control file, and the configuration file automatically. Do not create these files manually and do not use your own configuration files. If you already did it, remove them before starting the installation of HPOM. |



| Question   | Instruction   |
|--|---|
|  | The entered HARG name may not be one of the already existing names.   |
| Server virtual hostname                                  | Enter the short name of the virtual host (for example, virtip1).  |
| Separate Database from Server                            | <p>To separate the database from the HP Operations management server, press <b>y</b>. The following question is displayed:</p> <p>Configure Server and Database running as separate HA resource groups?</p> <ul style="list-style-type: none"> <li>• <i>If you want to configure the database as a separate HARG:</i> Press <b>ENTER</b> to accept the default answer. You are prompted to enter the database HARG name (for example, ov-db) and the database virtual hostname (for example, virtip2). The entered HARG name may not be one of the already existing names.</li> <li>• <i>If you do not want to configure the database as a separate HARG:</i> Press <b>n</b> followed by <b>ENTER</b> and continue with the HP Operations management server installation where the database is an independent database server.</li> </ul> |
| Will HPOM run on an Oracle instance ( n for PostgreSQL ) | Choose the appropriate option depending on the database type HPOM will run on.  |
| <i>Oracle only:</i> Oracle Base                          | Choose the Oracle database base directory (the default is /opt/oracle).   |
| <i>PostgreSQL only:</i> PSQL cluster directory           | Choose the directory where you want the cluster to be created (it must be empty) or where the cluster was created by using the psqlcluster tool.  |
| Database Table Data Mount Point                          | Choose the mount point where database table data files are stored.  |
| Database Index Mount Point                               | Choose the mount point where database index files are stored (by default, it is the same as the database table data mount point).   |

The ovoconfigure script continues with checking shared file systems.

2. If you want to add a new shared file system, follow these steps:

a. Press **y** followed by **ENTER**.

You are prompted to enter the shared file system mount point.

b. Type the desired shared file system mount point, and then press **ENTER**.

Otherwise, accept the default value `n` by pressing **ENTER**.

The `ovoconfigure` script continues with checking virtual hosts.

3. If you want to add a new virtual host, follow these steps:

a. Press **y** followed by **ENTER**.

You are prompted to add the virtual hostname.

b. Type the desired virtual hostname (for example, `virtip3`), and then press **ENTER**.

Otherwise, accept the default value `n` by pressing **ENTER**.

The summary of all shared file systems and virtual hosts is displayed, after which the `ovoconfigure` script asks you if you want to continue.

4. Press **ENTER**.

An output similar to the following one should appear:

```
Cluster preconfiguration . . . . . OK
```

5. Press **ENTER** to continue with the database configuration and the server initialization.

Make sure to answer all the questions related to the database configuration and the server initialization.

6. Press **ENTER** to continue with the cluster configuration.

An output similar to the following one should appear:

```
Cluster configuration on FIRST cluster node
-----
OVHARG configuration . . . . . OK
Configure Server cluster configuration . . . . OK
Server cluster postconfiguration . . . . . OK
Server HARG creation . . . . . OK
Database HARG creation . . . . . OK
Cluster successfully configured
```

7. Press **ENTER** to continue.

The server final configuration starts. It consists of the following:

- Management server policy group assignment
- Subagents configuration
- Java GUI configuration
- Web server configuration
- Certificates backup

8. Press **ENTER** to start the HP Operations management server as an HARG.

At this point, agent deployment packages are installed, the local agent is configured, and the configuration is distributed to the local agent.

**Note:** To limit the server communication to the virtual IP only, run the following command:

```
/opt/OV/bin/ovconfchg -ovrg server -ns bbc.http -set CLIENT_BIND_ADDR \  
<virtual_IP_of_HPOM_cluster>
```

## Installing and Configuring the HP Operations Management Server on an Additional Cluster Node

To install and configure the HP Operations management server on an additional cluster node, follow these steps:

1. After the `ovoconfigure` script detects a special environment, you are asked if you want to run the HP Operations management server as an HARG.

Press **y** followed by **ENTER**.

The script checks the remote shell connection and the secure remote shell connection, and then the following question appears:

Would you prefer to use REMSH even though SSH is enabled?

2. Press **ENTER** to accept the default answer (that is, `n`).

You are prompted to enter the HARG name.

3. Press **ENTER** to accept the default answer (that is, `ov-server`), or specify an alternative name for the HARG, and then press **ENTER**.

**Caution:** The entered HARG must be configured and running on the first cluster node.

An output similar to the following one should appear:

```
Cluster preconfiguration . . . . . OK
```

4. Press **ENTER** to continue with the server initialization.

During the server initialization, `ovoconfigure` performs the integration into the start-stop sequence.

5. Press **ENTER** to continue with the cluster configuration.

An output similar to the following one should appear:

```
Cluster configuration on ADDITIONAL cluster node  
-----  
OVHARG configuration . . . . . OK
```

```
Configure Server cluster configuration . . . . OK  
Server cluster postconfiguration . . . . . OK  
Adding local node to Server HARG . . . . . OK  
Adding local node to Database HARG . . . . . OK  
Cluster successfully configured
```

6. Press **ENTER** to continue with the server final configuration that consists of the following:
  - Management server policy group assignment
  - Java GUI configuration
  - Web server configuration
  - Agent deployment packages installation
  - Local agent configuration
  - Distributing configuration to the local agent

## Log Files

For details about the cluster-specific installation, check the following log files:

- `/var/opt/OV/log/OpC/mgmt_sv/installation.log.verbose`  
This log file contains the information about the success of the installation and eventual problems during the installation.
- `/var/opt/OV/hacluster/<HARG_name>/trace.loga`, `/var/opt/OV/hacluster/<HARG_name>/error.log`, and `/etc/cmcluster/<HARG_name>/ov-server.cntl.log`  
These log files contain the information about managing the HARG.

**Note:** The size of the HARG `trace.log` file is limited. When the maximum file size is reached, `trace.log` is moved into `trace.log.old` and the new information is written into a new `trace.log` file.

You can change the maximum size of the `trace.log` file by adding the following line to the `/var/opt/OV/hacluster/<HARG_name>/settings` file:

```
TRACING_FILE_MAX_SIZE=<maximum_size_in_kBytes>
```

For example:

<sup>a</sup>Only if previously enabled by running the following command:

```
/opt/OV/sbin/ovharg -tracing ov-server enable
```

The `trace.log` file is automatically updated with the information about starting the HARG during the installation on the first cluster node.

```
TRACING_FILE_MAX_SIZE=7000
```

# Chapter 11: Installing HPOM in a Veritas Cluster Environment

## In This Chapter

This chapter describes how to install and configure the HP Operations management server in a Veritas cluster environment. It also contains the information about installation requirements and log files.

For more information about managing HPOM in a cluster environment, see ["Managing HPOM in a Cluster Environment" on page 176](#).

## Installation Requirements

To run HPOM in a Veritas cluster environment, your system must meet the following requirements:

- HP-UX 11i v3 on HP Integrity
- Veritas Cluster Server 5.1 or 6.1
- Make sure to use Veritas Volume Manager as the logical volume manager.

For additional requirements about installing HPOM, see ["Installation Requirements for the Management Server" on page 13](#).

## Installing and Configuring the HP Operations Management Server in a Cluster Environment

To install and configure the HP Operations management server in a cluster environment, you must complete the following tasks:

- **On the first cluster node:**
  - Task 1: ["Before You Install the HP Operations Management Server on the First Cluster Node" on the next page](#)
  - Task 2: ["Installing a Database Server for HPOM in a Cluster Environment" on page 216](#)

- [Task 3: "Installing and Configuring the HP Operations Management Server on Cluster Nodes" on page 222](#)
- **On each additional cluster node:**
  - [Task 1: "Before You Install the HP Operations Management Server on Additional Cluster Nodes" on page 215](#)
  - [Task 2: "Installing a Database Server for HPOM in a Cluster Environment" on page 216](#)
  - [Task 3: "Installing and Configuring the HP Operations Management Server on Cluster Nodes" on page 222](#)

**Caution:** You cannot install HPOM simultaneously on all cluster nodes. When the installation process is completed on one cluster node, begin the installation on the next node, until HPOM is installed on all the nodes in a cluster environment.

## Before You Install the HP Operations Management Server on the First Cluster Node

Before you install the HP Operations management server on the first cluster node, you must perform appropriate preparation procedures depending on the cluster environment you want to configure.

For detailed information about configuration scenarios, see ["Configuration Scenarios" on page 176](#).

Depending on the configuration scenario you choose, see one of the following sections:

- *Basic environment:* ["Preparation Steps for the First Cluster Node in a Basic Environment" on the next page](#)
- *Decoupled environment:* ["Preparation Steps for the First Cluster Node in a Decoupled Environment" on page 210](#)
- *Independent database server:* ["Preparation Steps for the First Cluster Node in a Cluster Environment Using an Independent Database Server" on page 214](#)

## Preparation Steps for the First Cluster Node in a Basic Environment

Before you install the HP Operations management server in a cluster environment, follow these steps:

1. Define the following:
  - a. Define the `ov-dg` disk device group consisting of at least one shared disk for the HARG.
  - b. Define the following volumes within the `ov-dg` disk device group:
    - `ov-volume-etc`
    - `ov-volume-var`
    - `ov-volume-lcore`
    - `ov-volume-db-data`
    - *If the database index directory is on a different volume than the main data directory: `ov-volume-db-index`*
    - *If the PostgreSQL database table data directory is on a different volume than the main cluster directory: `ov-volume-db-tables`*
    - *If you choose to install Oracle database server binaries on a shared disk: `ov-volume-db-core`*

**Note:** When defining a disk device group or any of the volumes within the disk device group, you can specify an optional name.

2. Make sure that the following shared file systems are available:
  - `/etc/opt/OV/share`
  - `/var/opt/OV/share`
  - `/var/opt/OV/shared/server`
  - HP Operations management server database

**Note:** *Oracle only:* You may select an alternative mount point. The default is the following:

`/u01/oradata/<ORACLE_SID>`

In this instance, `<ORACLE_SID>` is the value of the `ORACLE_SID` variable used for the configuration of the HP Operations management server database. It is usually set to `openview`.

- *If the database index directory is on a different volume than the main data directory:*



HP Operations management server database index files

- *If the PostgreSQL database table data directory is on a different volume than the main cluster directory:* PostgreSQL database table data files
- *If you choose to install Oracle database server binaries on a shared disk:* Oracle database server binaries (equal to the value of the ORACLE\_BASE variable)

Table 27: Disk Space for Shared File Systems

| Shared File System   | Recommended         |
|--|---------------------|
| /etc/opt/OV/share  | 2 GB                |
| /var/opt/OV/share  | 2.5 GB <sup>a</sup> |
| /var/opt/OV/shared/server                                    | 2.5 GB              |
| Database data directory                                      | 2 GB <sup>b</sup>   |
| Database index directory ( <i>optional</i> )                 | 100 MB <sup>b</sup> |
| PostgreSQL database table data directory ( <i>optional</i> ) | 2 GB                |
| Oracle database server binaries ( <i>optional</i> )          | 10 GB               |

3. Prepare mount points for the shared file systems listed in the previous step.
4. Import the `ov-dg` disk device group on the current node by running the following command:  
`/usr/sbin/vxdg import ov-dg`
5. Start the volumes by running the following command:  
`/usr/sbin/vxvol -g ov-dg startall`
6. Check if all the volumes of the `ov-dg` disk device group are started by running the following command:  
`/usr/sbin/vxinfo -g ov-dg`

If the volumes are started, an output similar to the following one appears:

```
ov-volume-var      Started
ov-volume-etc      Started
ov-volume-lcore    Started
ov-volume-db-data  Started
```

<sup>a</sup>Further disk space will be required when SPIs are installed.

<sup>b</sup>For small-sized to medium-sized installations. Larger installations and high numbers of messages will result in greater space requirements.

```
ov-volume-db-index Started  
ov-volume-db-core Started
```

7. Mount the shared file systems on the prepared mount points as follows:
  - a. `/usr/sbin/mount -F <FSType> /dev/vx/dsk/ov-dg/ov-volume-etc \ /etc/opt/OV/share`
  - b. `/usr/sbin/mount -F <FSType> /dev/vx/dsk/ov-dg/ov-volume-var \ /var/opt/OV/share`
  - c. `/usr/sbin/mount -F <FSType> /dev/vx/dsk/ov-dg/ov-volume-lcore \ /var/opt/OV/shared/server`
  - d. `/usr/sbin/mount -F <FSType> /dev/vx/dsk/ov-dg/ov-volume-db-data \ <database_mount_point>`
  - e. *Optional:* If the database index directory is on a different volume than the main data directory:  
`/usr/sbin/mount -F <FSType> /dev/vx/dsk/ov-dg/ov-volume-db-index \ <database_index_mount_point>`
  - f. *Optional:* If the PostgreSQL database table data directory is on a different volume than the main cluster directory:  
`/usr/sbin/mount -F <FSType> /dev/vx/dsk/ov-dg/ov-volume-db-tables \ <postgres_table_data_mount_point>`
  - g. *Optional:* If you choose to install Oracle database server binaries on a shared disk:  
`/usr/sbin/mount -F <FSType> /dev/vx/dsk/ov-dg/ov-volume-db-core \ <oracle_binaries_mount_point>`

8. Activate the HP Operations management server virtual network IP:

```
ifconfig <network_interface>:1
```

For example, you can configure the IP address as follows:

```
ifconfig <network_interface>:1 inet <IP> netmask 255.255.0.0 up
```

In this instance, `<network_interface>` is the physical network interface used for the virtual IP (lan0 is used as the network interface on HP-UX on HP Integrity) and `<IP>` is the IP address of the virtual host that you previously selected.

## Preparation Steps for the First Cluster Node in a Decoupled Environment

Before you install the HP Operations management server in a cluster environment, follow these steps:

1. Define the following:
  - a. Define the `ov-dg` disk device group consisting of at least one shared disk for the HARG.
  - b. Define the following volumes within the `ov-dg` disk device group:

- o ov-volume-etc
  - o ov-volume-var
  - o ov-volume-lcore
- c. Define the `ov-db-dg` disk device group consisting of at least one shared disk for the HARG.
- d. Define the following volumes within the `ov-db-dg` disk device group:
- o `ov-volume-db-data`
  - o *If the database index directory is on a different volume than the main data directory:* `ov-volume-db-index`
  - o *If the PostgreSQL database table data directory is on a different volume than the main cluster directory:* `ov-volume-db-tables`
  - o *If you choose to install Oracle database server binaries on a shared disk:* `ov-volume-db-core`

**Note:** When defining a disk device group or any of the volumes within the disk device group, you can specify an optional name.

2. Make sure that the following shared file systems are available:

- `/etc/opt/OV/share`
- `/var/opt/OV/share`
- `/var/opt/OV/shared/server`
- HP Operations management server database

**Note:** *Oracle only:* You may select an alternative mount point. The default is the following:

`/u01/oradata/<ORACLE_SID>`

In this instance, `<ORACLE_SID>` is the value of the `ORACLE_SID` variable used for the configuration of the HP Operations management server database. It is usually set to `openview`.

- *If the database index directory is on a different volume than the main data directory:* HP Operations management server database index files
- *If the PostgreSQL database table data directory is on a different volume than the main cluster directory:* PostgreSQL database table data files
- *If you choose to install Oracle database server binaries on a shared disk:* Oracle database server binaries (equal to the value of the `ORACLE_BASE` variable)

Table 28: Disk Space for Shared File Systems

| Shared File System   | Recommended         |
|--|---------------------|
| /etc/opt/OV/share  | 2 GB                |
| /var/opt/OV/share  | 2.5 GB <sup>a</sup> |
| /var/opt/OV/shared/server                                    | 2.5 GB              |
| Database data directory                                      | 2 GB <sup>b</sup>   |
| Database index directory ( <i>optional</i> )                 | 100 MB <sup>b</sup> |
| PostgreSQL database table data directory ( <i>optional</i> ) | 2 GB                |
| Oracle database server binaries ( <i>optional</i> )          | 10 GB               |

3. Prepare mount points for the shared file systems listed in the previous step.
4. Import the `ov-dg` and `ov-db-dg` disk device groups on the current node by running the following commands:

```
/usr/sbin/vxdg import ov-dg
/usr/sbin/vxdg import ov-db-dg
```

5. Start the volumes by running the following commands:

```
/usr/sbin/vxvol -g ov-dg startall
/usr/sbin/vxvol -g ov-db-dg startall
```

6. Check the following:
  - a. Check if all the volumes of the `ov-dg` disk device group are started by running the following command:

```
/usr/sbin/vxinfo -g ov-dg
```

If the volumes are started, an output similar to the following one appears:

```
ov-volume-var    Started
ov-volume-etc    Started
ov-volume-lcore  Started
```

- b. Check if all the volumes of the `ov-db-dg` disk device group are started by running the following command:

```
/usr/sbin/vxinfo -g ov-db-dg
```

<sup>a</sup>Further disk space will be required when SPIs are installed.

<sup>b</sup>For small-sized to medium-sized installations. Larger installations and high numbers of messages will result in greater space requirements.

If the volumes are started, an output similar to the following one appears:

```
ov-volume-db-data    Started
ov-volume-db-index   Started
ov-volume-db-core    Started
```

7. Mount the shared file systems on the prepared mount points as follows:
  - a. `/usr/sbin/mount -F <FSType> /dev/vx/dsk/ov-dg/ov-volume-etc \ /etc/opt/OV/share`
  - b. `/usr/sbin/mount -F <FSType> /dev/vx/dsk/ov-dg/ov-volume-var \ /var/opt/OV/share`
  - c. `/usr/sbin/mount -F <FSType> /dev/vx/dsk/ov-dg/ov-volume-lcore \ /var/opt/OV/shared/server`
  - d. `/usr/sbin/mount -F <FSType> /dev/vx/dsk/ov-db-dg/ov-volume-db-data \ <database_mount_point>`
  - e. *Optional:* If the database index directory is on a different volume than the main data directory:  
`/usr/sbin/mount -F <FSType> /dev/vx/dsk/ov-db-dg/ov-volume-db-index \ <database_index_mount_point>`
  - f. *Optional:* If the PostgreSQL database table data directory is on a different volume than the main cluster directory:  
`/usr/sbin/mount -F <FSType> /dev/vx/dsk/ov-db-dg/ov-volume-db-tables \ <postgres_table_data_mount_point>`
  - g. *Optional:* If you choose to install Oracle database server binaries on a shared disk:  
`/usr/sbin/mount -F <FSType> /dev/vx/dsk/ov-db-dg/ov-volume-db-core \ <oracle_binaries_mount_point>`

8. Activate the HP Operations management server virtual network IP:

```
ifconfig <network_interface>:1
```

For example, you can configure the IP address as follows:

```
ifconfig <network_interface>:1 inet <IP> netmask 255.255.0.0 up
```

In this instance, `<network_interface>` is the physical network interface used for the virtual IP (lan0 is used as the network interface on HP-UX on HP Integrity) and `<IP>` is the IP address of the virtual host that you previously selected.

9. Activate the database virtual network IP:

```
ifconfig <network_interface>:2
```

For example, you can configure the IP address as follows:

```
ifconfig <network_interface>:2 inet <IP> netmask 255.255.0.0 up
```

In this instance, `<network_interface>` is the physical network interface used for the virtual IP (lan0 is used as the network interface on HP-UX on HP Integrity) and `<IP>` is the IP address of the virtual host that you previously selected.

# Preparation Steps for the First Cluster Node in a Cluster Environment Using an Independent Database Server

Before you install the HP Operations management server in a cluster environment, follow these steps:

1. Define the following:
  - a. Define the `ov-dg` disk device group consisting of at least one shared disk for the HARG.
  - b. Define the following volumes within the `ov-dg` disk device group:
    - o `ov-volume-etc`
    - o `ov-volume-var`
    - o `ov-volume-lcore`

**Note:** When defining a disk device group or any of the volumes within the disk device group, you can specify an optional name.

2. Make sure that the following shared file systems are available:
  - `/etc/opt/OV/share`
  - `/var/opt/OV/share`
  - `/var/opt/OV/shared/server`

Table 29: Disk Space for Shared File Systems

| Shared File System                     | Recommended         |
|--|---------------------|
| <code>/etc/opt/OV/share</code>         | 2 GB                |
| <code>/var/opt/OV/share</code>         | 2.5 GB <sup>a</sup> |
| <code>/var/opt/OV/shared/server</code> | 2.5 GB              |

3. Prepare mount points for the shared file systems listed in the previous step.
4. Import the `ov-dg` disk device group on the current node by running the following command:  
`/usr/sbin/vxdg import ov-dg`
5. Start the volumes by running the following command:  
`/usr/sbin/vxvol -g ov-dg startall`

<sup>a</sup>Further disk space will be required when SPIs are installed.

6. Check if all the volumes of the `ov-dg` disk device group are started by running the following command:

```
/usr/sbin/vxinfo -g ov-dg
```

If the volumes are started, an output similar to the following one appears:

```
ov-volume-var    Started
ov-volume-etc    Started
ov-volume-lcore  Started
```

7. Mount the shared file systems on the prepared mount points as follows:
  - a. `/usr/sbin/mount -F <FSType> /dev/vx/dsk/ov-dg/ov-volume-etc \ /etc/opt/OV/share`
  - b. `/usr/sbin/mount -F <FSType> /dev/vx/dsk/ov-dg/ov-volume-var \ /var/opt/OV/share`
  - c. `/usr/sbin/mount -F <FSType> /dev/vx/dsk/ov-dg/ov-volume-lcore \ /var/opt/OV/shared/server`
8. Activate the HP Operations management server virtual network IP:

```
ifconfig <network_interface>:1
```

For example, you can configure the IP address as follows:

```
ifconfig <network_interface>:1 inet <IP> netmask 255.255.0.0 up
```

In this instance, `<network_interface>` is the physical network interface used for the virtual IP (`lan0` is used as the network interface on HP-UX on HP Integrity) and `<IP>` is the IP address of the virtual host that you previously selected.

## Before You Install the HP Operations Management Server on Additional Cluster Nodes

Before you install the HP Operations management server on additional cluster nodes, you must perform appropriate preparation procedures. The preparation steps are identical for all HP Operations management server installation scenarios.

### Preparation Steps for Additional Cluster Nodes

The following preconditions must be met before installing the HP Operations management server on an additional cluster node:

- The HP Operations management server must already be installed and running on one of the cluster nodes. This enables you to add a local node to the HP Operations management server configuration,

and install and start the HP Operations agent software on the local node.

- On the node where HPOM is running, enable the remote shell connection for the `root` user to the node where you plan to install the HP Operations management server. You can do this by adding the following line into the `/.rhosts` file:

```
<node> root
```

You can check if the remote shell is enabled by running the following command:

```
remsh <active_node> -l root -n ls
```

A list of the files on the `root` directory from the node where the HP Operations management server is running should be displayed.

In more secure environments, you can set up a secure shell (SSH) connection between the node where you plan to install an HP Operations management server and the node where the HP Operations management server is running.

For the HP Operations management server installation, you must enable passwordless SSH access for the `root` user between these two nodes. During the installation, the `ssh` and `scp` commands are used. Therefore, both commands must be accessible from the main path.

You can check if the secure remote shell is enabled by running the following command:

```
ssh <active_node> -l root -n ls
```

The type of connection is detected automatically. A secure connection has a higher priority if both types of connection are enabled.

- Shared file systems may not be mounted on this cluster node. They are already mounted on the cluster node where the HP Operations management server is running.
- The virtual IP may not be activated on this node because it is already used on the node where the HP Operations management server is running.

## Installing a Database Server for HPOM in a Cluster Environment

Before installing a database server for HPOM in a cluster environment, consider the following:

- *If you use the Oracle database:*

The Oracle database server binaries must be installed on a local disk to enable the high availability of the Oracle database server and consequently of the HP Operations management server. If the Oracle database server binaries become corrupt, it is very important that the Oracle database server can be switched to another cluster node with intact Oracle database server binaries.

In exceptional cases, you may want to install the Oracle database server binaries on a shared disk. This way only one set of Oracle database server binaries is installed but there is a greater risk of



losing Oracle availability. If you choose the decoupled scenario for installing HPOM, a separate Oracle client installation is also needed.

- *If you use the PostgreSQL database:*

The PostgreSQL database server binaries must be installed locally on all nodes. The installation path must be the same on all cluster nodes.

Table 30 shows which procedure to follow depending on the configuration scenario you choose.

Table 30: Configuration Scenarios Based on the File System Location

|                    | Database server location                                     |  |   |
|--------------------|--|--|---|
|                    | Local File System  | Shared File System (Exceptional)   | Remote File System                                      |
| <b>Basic</b>       | "Basic Management Server Configuration" on the next page     | <ul style="list-style-type: none"> <li>• <i>Oracle:</i> "Basic Management Server Configuration" on page 219</li> <li>• <i>PostgreSQL:</i> "Basic Management Server Configuration" on page 221</li> </ul>         |   |
| <b>Decoupled</b>   | "Decoupled Management Server Configuration" on the next page | <ul style="list-style-type: none"> <li>• <i>Oracle:</i> "Decoupled Management Server Configuration" on page 219</li> <li>• <i>PostgreSQL:</i> "Decoupled Management Server Configuration" on page 221</li> </ul> |   |
| <b>Independent</b> | "Independent Database Server Configuration" on the next page |  | "Independent Database Server Configuration" on page 221 |

## Database Server on a Local Disk

### Basic Management Server Configuration

Depending on which database you want to install, follow the procedure described in ["Installing an Oracle Database" on page 27](#) or ["Installing a PostgreSQL Database" on page 41](#).

### Decoupled Management Server Configuration

Depending on which database you want to install, follow the procedure described in ["Installing an Oracle Database" on page 27](#) or ["Installing a PostgreSQL Database" on page 41](#).

### Independent Database Server Configuration

- *First cluster node*

Depending on which database you want to install, follow the procedure described in ["Installing an Oracle Database" on page 27](#) or ["Installing a PostgreSQL Database" on page 41](#).

- *Additional cluster node*

Depending on your database type, install either the Oracle Net Services and the Oracle client or the PostgreSQL client on the local disk. All other database configuration steps are performed by the HP Operations management server installation script.

**Note:** After the database server installation, on all HP Operations management server cluster nodes, create a script or a binary so that the HP Operations management server can determine the status of the database:

```
/opt/OV/bin/OpC/utills/ha/ha_check_db
```

The exit code of this script or binary must be 0 if the database server runs, or other than 0 if it does not run.

*PostgreSQL only:* You can determine if the PostgreSQL server is up and running by checking if the `<cluster_dir>/postmaster.pid` file exists.

When the following questions appear during the independent database server configuration, make sure that you answer as follows:

| Question  | Answer |
|---|--------|
| Separate Database from Server?                                | y      |
| Configure Server and Database running as separate HA resource | n      |

| Question  | Answer   |
|---|----------|
| groups?   |          |
| <i>Oracle only:</i> Set up the database manually (local/remote)?        | <b>y</b> |
| <i>Oracle only:</i> Is the manually configured database already set up? | <b>n</b> |

## Database Server on a Shared Disk (Exceptional)

Depending on your database type, see one of the following sections:

- ["Oracle Database Server on a Shared Disk" below](#)
- ["PostgreSQL Database Server on a Shared Disk" on page 221](#)

## Oracle Database Server on a Shared Disk

The installation script automatically detects if Oracle database server binaries are located on a shared disk, or if the ORACLE\_BASE directory is a mount point for an external file system containing the Oracle database server binaries (the file system must always be mounted on the ORACLE\_BASE mount point).

### Basic Management Server Configuration

Install an Oracle database as described in ["Installing an Oracle Database" on page 27](#).

### Decoupled Management Server Configuration

When the Oracle database is separated from the HP Operations management server and Oracle database server binaries are installed on a shared disk, install the Oracle client on the local disk, so that the HP Operations management server can connect to the Oracle database server through the Oracle client. You must install the Oracle client on a location other than ORACLE\_BASE. The path to the client must be the same on all HP Operations management server cluster nodes.

- *First cluster node*

Install the Oracle client on the local disk, and then the Oracle server on the shared disk as described in ["Installing an Oracle Database" on page 27](#). Do not use the Instant Client, but the full Oracle Client (the Runtime installation type). Make sure that you use the 32-bit version of the client.

**Note:** When installing and configuring the HP Operations management server, the ORACLE\_BASE and ORACLE\_HOME variables must be set to the Oracle database server location.

#### Enabling Database Network Connectivity

After installing the HP Operations management server, follow these steps:

- a. Copy the following configuration files from the Oracle database server location on the shared disk (`<Oracle_server_home>/network/admin/`) to the Oracle client location on the local disk (`<Oracle_client_home>/network/admin/`):
  - o listener.ora
  - o sqlnet.ora
  - o tnsnames.ora
  - o tnsnav.ora

- b. To contain the location of the Oracle client software, modify the ORACLE\_HOME variable at the following location:

```
/etc/opt/OV/share/conf/ovdbconf
```

- c. Stop the HP Operations management server as an HARG by running the following command:

```
/opt/OV/bin/ovharg_config ov-server -stop <Local_hostname>
```

- d. Add the following lines to the `/etc/rc.config.d/ovoracle` file:

```
ORACLE_HOME=<Oracle_Server_Home>  
ORACLE_SID=<ORACLE_SID>  
export ORACLE_HOME ORACLE_SID
```

The `/etc/rc.config.d/ovoracle` file is used as a configuration file by the `/sbin/init.d/ovoracle` script, which is used by the Oracle HARG to start the Oracle database.

**Note:** Make sure that you use the latest version of the `/sbin/init.d/ovoracle` script. Copy the file from `newconfig` by running the following command:

```
cp /opt/OV/newconfig/OpC/sbin/init.d/ovoracle /sbin/init.d/ovoracle
```

- e. Remove the existing Oracle client library links from the `/opt/OV/lib` directory and replace them with the following ones:

```
ln -sf <ORACLE_HOME>/lib32/libc1ntsh.so /opt/OV/lib/hpux32/libc1ntsh.so  
ln -sf <ORACLE_HOME>/lib32/libc1ntsh.so /opt/OV/lib/hpux32/libc1ntsh.so.11.1  
ln -sf <ORACLE_HOME>/lib32/libn11.so /opt/OV/lib/hpux32/libn11.so  
ln -sf <ORACLE_HOME>/lib32/libn12.so /opt/OV/lib/hpux32/libn12.so
```

- f. Start the HP Operations management server as an HARG by running the following command:

```
/opt/OV/bin/ovharg_config ov-server -start <Local_hostname>
```

The HP Operations management server will now connect to the Oracle database server through the Oracle client.

- *Additional cluster node*

Install the Oracle client on the local disk. All other database configuration steps are performed by the HP Operations management server installation script.

**Note:** When installing and configuring the HP Operations management server, the `ORACLE_HOME` variable must be set to the Oracle client location.

## PostgreSQL Database Server on a Shared Disk

### Basic Management Server Configuration

Install a PostgreSQL database as described in ["Installing a PostgreSQL Database" on page 41](#).

### Decoupled Management Server Configuration

On all cluster nodes, install the PostgreSQL client and server on the local disk as described in ["Installing a PostgreSQL Database" on page 41](#). All other database configuration steps are performed by the HP Operations management server installation script.

## Database Server on a Remote File System

### Independent Database Server Configuration

- *First cluster node*

Depending on your database type, configure the database as described in ["Setting Up HPOM with a Remote/Manual Oracle Database" on page 86](#) or ["Setting Up HPOM with a Remote/Manual PostgreSQL Database" on page 98](#).

- *Additional cluster node*

Depending on your database type, install either the Oracle Net Services and the Oracle client or the PostgreSQL client on the local disk. All other database configuration steps are performed by the HP Operations management server installation script.

**Note:** After the database server installation, on all HP Operations management server cluster nodes, create a script or a binary so that the HP Operations management server can determine the status of the database:

```
/opt/OV/bin/OpC/utlils/ha/ha_check_db
```

The exit code of this script or binary must be 0 if the database server runs, or other than 0 if it does not run.

*PostgreSQL only:* You can determine if the PostgreSQL server is up and running by checking if the `<cluster_dir>/postmaster.pid` file exists.

When the following questions appear during the independent database server configuration, make sure that you answer as follows:

| Question  | Answer   |
|---|----------|
| Separate Database from Server?  | <b>y</b> |
| Configure Server and Database running as separate HA resource groups?   | <b>n</b> |
| <i>Oracle only:</i> Set up the database manually (local/remote)?        | <b>y</b> |
| <i>Oracle only:</i> Is the manually configured database already set up? | <b>n</b> |

## Installing and Configuring the HP Operations Management Server on Cluster Nodes

When installing HPOM in a cluster environment, you must answer some questions and specify some values differently than in the stand-alone HPOM installation. These cluster-specific questions differ depending on whether you are installing and configuring the HP Operations management server on the first cluster node or on an additional cluster node.

**Caution:** Make sure that cluster node names are the same as hostnames. Otherwise, the configuration fails.

## Installing and Configuring the HP Operations Management Server on the First Cluster Node

To install and configure the HP Operations management server on the first cluster node, follow these steps:

1. After the `ovoconfigure` script detects a special environment, provide answers to the following cluster-specific questions:

| Question                                | Instruction  |
|---|--|
| Run HPOM Server as an HA resource group | Press <b>y</b> followed by <b>ENTER</b> .<br>The script checks the remote shell connection and the secure remote shell connection. |
| Would you prefer to                     | Press <b>ENTER</b> to accept the default answer (that is, n).  |

| Question   | Instruction   |
|--|---|
| use REMSH even though SSH is enabled                     |   |
| HA Resource Group name                                   | <p>Press <b>ENTER</b> to accept the default answer (that is, <code>ov-server</code>), or specify an alternative name for the HARG, and then press <b>ENTER</b>.</p> <p>HARGs are created during the installation of HPOM. The <code>ovinstall</code> script builds the package or the service control file, and the configuration file automatically. Do not create these files manually and do not use your own configuration files. If you already did it, remove them before starting the installation of HPOM.</p> <p>The entered HARG name may not be one of the already existing names.</p>   |
| Server virtual hostname                                  | Enter the short name of the virtual host (for example, <code>virtip1</code> ).  |
| Separate Database from Server                            | <p>To separate the database from the HP Operations management server, press <b>y</b>. The following question is displayed:</p> <p>Configure Server and Database running as separate HA resource groups?</p> <ul style="list-style-type: none"> <li>• <i>If you want to configure the database as a separate HARG:</i> Press <b>ENTER</b> to accept the default answer. You are prompted to enter the database HARG name (for example, <code>ov-db</code>) and the database virtual hostname (for example, <code>virtip2</code>). The entered HARG name may not be one of the already existing names.</li> <li>• <i>If you do not want to configure the database as a separate HARG:</i> Press <b>n</b> followed by <b>ENTER</b> and continue with the HP Operations management server installation where the database is an independent database server.</li> </ul> |
| Will HPOM run on an Oracle instance ( n for PostgreSQL ) | Choose the appropriate option depending on the database type HPOM will run on.  |
| <i>Oracle only:</i> Oracle Base                          | Choose the Oracle database base directory (the default is <code>/opt/oracle</code> ).   |
| <i>PostgreSQL only:</i> PSQL cluster directory           | Choose the directory where you want the cluster to be created (it   |

| Question                        | Instruction   |
|---------------------------------|---|
|                                 | must be empty) or where the cluster was created by using the <code>psqlcluster</code> tool.                                       |
| Database Table Data Mount Point | Choose the mount point where database table data files are stored.  |
| Database Index Mount Point      | Choose the mount point where database index files are stored (by default, it is the same as the database table data mount point). |

The `ovoconfigure` script continues with checking shared file systems.

2. If you want to add a new shared file system, follow these steps:
  - a. Press **y** followed by **ENTER**.

You are prompted to enter the shared file system mount point.

- b. Type the desired shared file system mount point, and then press **ENTER**.
- Otherwise, accept the default value `n` by pressing **ENTER**.

The `ovoconfigure` script continues with checking virtual hosts.

3. If you want to add a new virtual host, follow these steps:
  - a. Press **y** followed by **ENTER**.

You are prompted to add the virtual hostname.

- b. Type the desired virtual hostname (for example, `virtip3`), and then press **ENTER**.
- Otherwise, accept the default value `n` by pressing **ENTER**.

The summary of all shared file systems and virtual hosts is displayed, after which the `ovoconfigure` script asks you if you want to continue.

4. Press **ENTER**.

An output similar to the following one should appear:

```
Cluster preconfiguration . . . . . OK
```

5. Press **ENTER** to continue with the database configuration and the server initialization.

Make sure to answer all the questions related to the database configuration and the server initialization.

6. Press **ENTER** to continue with the cluster configuration.

An output similar to the following one should appear:

```
Cluster configuration on FIRST cluster node
-----
OVHARG configuration . . . . . OK
Configure Server cluster configuration . . . . OK
```



```
Server cluster postconfiguration . . . . . OK  
Server HARG creation . . . . . OK  
Database HARG creation . . . . . OK  
Cluster successfully configured
```

7. Press **ENTER** to continue.

The server final configuration starts. It consists of the following:

- Management server policy group assignment
- Subagents configuration
- Java GUI configuration
- Web server configuration
- Certificates backup

8. Press **ENTER** to start the HP Operations management server as an HARG.

At this point, agent deployment packages are installed, the local agent is configured, and the configuration is distributed to the local agent.

**Note:** To limit the server communication to the virtual IP only, run the following command:

```
/opt/OV/bin/ovconfchg -ovrg server -ns bbc.http -set CLIENT_BIND_ADDR \  
<virtual_IP_of_HPOM_cluster>
```

## Installing and Configuring the HP Operations Management Server on an Additional Cluster Node

To install and configure the HP Operations management server on an additional cluster node, follow these steps:

1. After the `ovoconfigure` script detects a special environment, you are asked if you want to run the HP Operations management server as an HARG.

Press **y** followed by **ENTER**.

The script checks the remote shell connection and the secure remote shell connection, and then the following question appears:

```
Would you prefer to use REMSH even though SSH is enabled?
```

2. Press **ENTER** to accept the default answer (that is, `n`).

You are prompted to enter the HARG name.

3. Press **ENTER** to accept the default answer (that is, `ov-server`), or specify an alternative name

for the HARG, and then press **ENTER**.

**Caution:** The entered HARG must be configured and running on the first cluster node.

An output similar to the following one should appear:

```
Cluster preconfiguration . . . . . OK
```

4. Press **ENTER** to continue with the server initialization.

During the server initialization, ovoconfigure performs the integration into the start-stop sequence.

5. Press **ENTER** to continue with the cluster configuration.

An output similar to the following one should appear:

```
Cluster configuration on ADDITIONAL cluster node
-----
OVHARG configuration . . . . . OK
Configure Server cluster configuration . . . . . OK
Server cluster postconfiguration . . . . . OK
Adding local node to Server HARG . . . . . OK
Adding local node to Database HARG . . . . . OK
Cluster successfully configured
```

6. Press **ENTER** to continue with the server final configuration that consists of the following:

- Management server policy group assignment
- Java GUI configuration
- Web server configuration
- Agent deployment packages installation
- Local agent configuration
- Distributing configuration to the local agent

## Log Files

For details about the cluster-specific installation, check the following log files:

- /var/opt/OV/log/OpC/mgmt\_sv/installation.log.verbose

This log file contains the information about the success of the installation and eventual problems during the installation.

- `/var/opt/OV/hacluster/<HARG_name>/trace.loga`, `/var/opt/OV/hacluster/<HARG_name>/error.log`, and `/var/VRTSvcs/log/engine_A.log`

These log files contain the information about managing the HARG.

**Note:** The size of the HARG `trace.log` file is limited. When the maximum file size is reached, `trace.log` is moved into `trace.log.old` and the new information is written into a new `trace.log` file.

You can change the maximum size of the `trace.log` file by adding the following line to the `/var/opt/OV/hacluster/<HARG_name>/settings` file:

```
TRACING_FILE_MAX_SIZE=<maximum_size_in_kBytes>
```

For example:

```
TRACING_FILE_MAX_SIZE=7000
```

<sup>a</sup>Only if previously enabled by running the following command:

```
/opt/OV/lbin/ovharg -tracing ov-server enable
```

The `trace.log` file is automatically updated with the information about starting the HARG during the installation on the first cluster node.

# Send Documentation Feedback

If you have comments about this document, you can [contact the documentation team](#) by email. If an email client is configured on this system, click the link above and an email window opens with the following information in the subject line:

**Feedback on Installation Guide (Operations Manager 9.21)**

Just add your feedback to the email and click send.

If no email client is available, copy the information above to a new message in a web mail client, and send your feedback to [docfeedback@hpe.com](mailto:docfeedback@hpe.com).

We appreciate your feedback!

