

# HP OpenView

## Smart Plug-In for IBM DB2 UDB

Version B.03.02 for HP OpenView for Windows

---

### User's Guide

## Legal Notices

### Warranty

The only warranties for HP products and services are set forth in the express warranty statements accompanying such products and services. Nothing herein should be construed as constituting an additional warranty. HP shall not be liable for technical or editorial errors or omissions contained herein.

The information contained herein is subject to change without notice.

### Restricted Rights Legend

Confidential computer software. Valid license from HP required for possession, use or copying. Consistent with FAR 12.211 and 12.212, Commercial Computer Software, Computer Software Documentation, and Technical Data for Commercial Items are licensed to the U.S. Government under vendor's standard commercial license.

### Copyright Notices

© Copyright 2006 Hewlett-Packard Development Company, L.P.

### Trademark Notices

All product names are the property of their respective trademark or service mark holders and are hereby acknowledged.

## Support

Please visit the HP OpenView website at:

<http://openview.hp.com/>

There you will find contact information and details about the products, services, and support that HP OpenView offers.

You can go directly to the HP OpenView eCare website at:

<http://support.openview.hp.com/>

The eCare support site includes:

- Downloadable documentation
- Troubleshooting information
- Patches and updates
- Problem reporting
- Training information
- Support program information



# Contents

- 1 Print History ..... 9
- 2 Conventions..... 10
- 3 Documentation Road Map ..... 11
- 4 Introduction ..... 12
- 5 Before You Begin ..... 14
  - Building Blocks ..... 14
  - DB2 Versions ..... 15
  - DB2 Server Operating Systems ..... 16
  - Perl on Managed Nodes..... 16
  - Perl on the Management Server..... 17
  - Internet Information Server Settings..... 17
  - OVO Server Versions ..... 17
    - Unix based OVO ..... 17
    - Windows based OVO..... 18
  - OVO Environment Requirements on the Managed Nodes ..... 18
  - Disk Space Requirements ..... 18
    - Space for Binaries and Configuration..... 18
    - Runtime Data..... 18
    - Memory (RAM) Requirements ..... 19
  - Performance Data Collection Tools..... 19
  - Self-Healing Collector ..... 19
- 6 Installing the DB2SPI ..... 20
  - Installing the DB2SPI Software on OVO for Windows ..... 20
    - Verifying Installation of the DB2SPI Software..... 20
  - Upgrading DB2SPI from an earlier Version..... 21
  - Configuring the ATOP Communication Layer..... 21
    - ATOP Server Setup ..... 21
  - Verification of Installation..... 23
    - Enabling the OVO/Windows Console Integration ..... 24

<b>7 Getting Started.....</b>	<b>25</b>
Setup Steps for OVO/Windows.....	25
Installing DB2SPI Licenses.....	26
Runtime License Installation.....	26
OVO Administrative Tasks.....	29
Assigning DB2SPI Administrator Responsibility.....	29
Assigning DB2 Operator Responsibility.....	29
Adding Nodes to Node Groups.....	30
Assigning DB2SPI Policies to individual Nodes.....	30
Preparing the Management Server Utilities.....	30
Distributing the DB2SPI Configuration Items.....	31
Configuring DB2 Instances.....	31
Preparatory Steps to Manage DB2 Servers in Clusters.....	32
OVO Agent Requirement on Windows Nodes.....	32
Instance Configuration Tool.....	33
Distinctions between UNIX and Windows Nodes.....	33
Configuration Workflow.....	33
Integration into Switch-Over Process for DB2 Clusters.....	39
Distributing the DB2SPI Templates (Policies).....	40
Policy Deployment with OVO/Windows.....	40
<b>8 Using the DB2SPI.....</b>	<b>42</b>
Components in the OVO Administration Scope.....	42
DB2SPI Node Groups.....	42
DB2SPI Tools.....	44
DB2SPI User Profiles (User Roles).....	48
DB2SPI Message-Source Templates (Policies).....	49
Other OVO Administrator Tasks.....	51
DB2SPI Administrator Tasks.....	52
General Remarks in Advance.....	52
DB2SPI License Tools.....	53
Maintaining DB2 Instances, Databases and the Service Tree.....	56
Affecting the Performance Data Flow.....	61
Other Tasks and Tools.....	65
DB2 Operator Tasks.....	67
Using DB2SPI Messages.....	67
Tool Execution – some general Remarks.....	69
DB2 Information Tools.....	70
Simple Access to DB2.....	78
Advanced Management Tools.....	80
<b>9 Concepts and Architecture.....</b>	<b>90</b>
ATOP Communication Layer.....	90
ATOP Configuration Settings.....	90

DB2SPI Internal Architecture.....	92
Support of non-Root Agents (Unix Managed Nodes) .....	93
Monitoring Log Files.....	93
DB2 Log Files .....	93
DB2SPI's own Log File .....	94
Log File Size Monitoring .....	94
Monitoring DB2 Processes.....	94
What is Process Monitoring?.....	94
Events from Process Monitoring .....	95
Performance Data Collection (Standard Metrics).....	96
General Data Flow.....	96
Naming Scheme for Metrics.....	99
Amount of Data Collected.....	99
Configuring Data Collection .....	100
Configuring Alert Thresholds.....	103
Service Management with OVO.....	103
DB2 Service Hierarchy.....	103
DB2 Service Functionality of the DB2SPI.....	104
OV Reporter Integration.....	105

## 10 De-installing the DB2SPI ..... 106

Clean-up the Managed Nodes.....	106
De-Assignment of Policies (OVO/Windows) .....	106
A quick Alternative .....	106
Removing the DB2SPI Package from the OVO/Windows Management Server.....	107
Removing DB2SPI Components from the OVO GUI.....	107

## 11 Troubleshooting..... 108

Troubleshooting Checklist.....	108
Area: DB2SPI Installation and Components .....	109
Installation on OVO/Windows .....	109
Files and Directories.....	110
Configuration Files.....	115
Log Files.....	118
Metric Storage on Unix Managed Nodes .....	118
DB2SPI Service Tree Configuration .....	118
Area: DB2SPI Usage.....	118
Common Areas and Symptoms .....	119
Problems with the ATOP Communication Layer.....	123
Tracing.....	123
Trace Configuration Location .....	124
Configuring the Trace Area.....	125
Extending Trace Information.....	125
Activating DB2SPI Tracing .....	126

DB2SPI Trace Files.....	126
Self-Management of the DB2SPI.....	126
Processes, Services and Scripts.....	127
ATOP Services.....	129
<b>12 Appendix A: DB2 Processes Monitored.....</b>	<b>130</b>
DB2 UDB Processes monitored in Unix Systems.....	130
Processes monitored in Windows Systems.....	131
<b>13 Appendix B: OV Reporter Templates Integration.....</b>	<b>132</b>
Installing DB2SPI Reports for OV Reporter.....	132
Prerequisites.....	132
Reports Installation.....	132
Verification of correct Installation.....	134
Creating Reports with the OV Reporter.....	135
Looking at DB2 Reports.....	135
DB2SPI Report Groups.....	135
Availability Report Group.....	135
I/O Report Group.....	136
Workload Report Group.....	137
OVO Report Group.....	139
<b>14 Appendix C: DB2SPI Licensing.....</b>	<b>141</b>
Licensing Policy.....	141
How to obtain Runtime Licenses.....	141
Install and activate a DB2SPI Runtime License.....	141
Tools for License Management.....	142



# 1 Print History

The manual printing date and part number indicate its current edition. The printing date will change when a new edition is printed. Minor changes may be made at reprint without changing the printing date. The manual part number will change when extensive changes are made.

Manual updates may be issued between editions to correct errors or document product changes. To ensure that you receive the updated or new editions, you should subscribe to the appropriate product support service. See your HP sales representative for details:

First edition: June 2001

Second edition (Release A.01.10): March 2002

Third edition (Release A.01.20): December 2002

Fourth edition (Release A.02.00 / B.02.00): October 2003

Fifth edition (Release A.02.05 / B:02.05): January 2004, reprint March 2004

Sixth edition (Release A.02.08 / B.02.08): June 2004

Seventh edition (Release B.02.10): March 2005

Eighth edition (Release A.03.00): December 2005

Ninth edition (Release B.03.02): September 2006

## 2 Conventions

In this book, HP OpenView Operations (OVO) is used as a synonym for all versions of the management product otherwise known as

- HP OpenView IT/Operations (ITO) (obsolete)
- HP OpenView VantagePoint Operations (VPO) (obsolete)
- HP OpenView Operations for HP-UX or for Solaris (OVO for HP-UX, OVO for Solaris) and OVO for Windows

In essence, they are all the same product and can host the SMART Plug-In for IBM DB2 Universal database.

# 3 Documentation Road Map

This section illustrates what information is available for the NiCE DB2SPI and where you can find it. The following manuals are available in PDF format only with the DB2SPI:

User's Guide

Reference Guide

Software Release Notes

In addition to the documentation for the DB2SPI, related OpenView products also provide a comprehensive set of manuals, which aim to assist you in using the products and improving your understanding of the underlying concepts. Table 1: lists the documentation provided with products that are related to the DB2SPI.

**Table 2: Related Documents**

HP OpenView Product Name	Manual Title
Operations for UNIX / Windows	Administrators reference Concepts guide Configuring circuits for OVO DCE agents concept and configuration guide HTTPS agents concept and configuration guide Installation guide Java GUI operator's guide <i>(more available, please refer to the OpenView support pages)</i>
Performance Manager	Administrator's Guide Guide to Performance Manager for users of PerfView User's guide and tutorials
Performance Agent	Data Source and integration Guide Installation and Configuration User's Guide Tracking your Transactions Installation and Configuration Guide Application Response Measurement API Guide (Windows only)

# 4 Introduction

This section describes what the DB2SPI is, what it can do, and how you can use it to improve the management of your DB2 environment. This section covers the following topics:

- What is IBM DB2 UDB?
- What is the DB2SPI?
- Managing DB2 instances with the DB2SPI
- Limitations

## What is IBM DB2 UDB?

DB2 Universal Database (DB2 UDB) is a powerful relational database management system (RDBMS) from IBM. It is available on a number of different platforms, ranging from Windows, Linux to various UNIX platforms. DB2 is also available on mainframe computers (OS/390, IBM zSeries) and minicomputers (AS/400, IBM iSeries), but this is a different implementation of DB2 and not yet covered with the DB2SPI. This version of DB2 that is managed by the DB2SPI is named the "LUW" version, indicating Linux, Unix, Windows. Scalability of DB2 for LUW platforms is provided by a range of different editions whose names reflect the product's scope and scale, for example, "Personal", "Workgroup" and "Enterprise" Edition and is also available for as distributed setup in "Extended Enterprise" (EEE, version 7.x) and "Enterprise Server" (ESE, version 8.x) editions.

## What is the DB2SPI?

The DB2SPI is designed to simplify the management of DB2 databases by integrating specific DB2 components into HP OpenView Operations (OVO). The integration of the two products allows you to use the powerful problem-management features of OVO to manage and monitor the DB2 environment from one central location. The DB2SPI provides the following high-level features:

- Monitoring of DB2 log files and processes and proper alerting if essential processes are discovered to have died or entries in the monitored log files relate to serious or critical issues in the DB2 environment
- Integrating DB2 applications into the OVO GUI (DB2 administration capabilities)
- Collecting a large amount of performance data
- Threshold monitoring of selected performance data
- Definition and management of multiple DB2 instances and databases
- Integration of DB2 instances and databases into the OV ServiceNavigator (OVO/Unix) resp. the integrated service view (OVO/Windows), thus treating them as services
- Graphing of collected performance data with OV Performance Manager
- Service reports are provided with the OV Reporter integration, enabling comprehensive reporting of the DB2 system status

# Managing DB2 instances with the DB2SPI

Since a DB2 server can consist of a number of individual DB2 instances a configuration program is provided that allows you to define which instances you want to monitor. The DB2SPI allows you to monitor any number of DB2 instances on each DB2 system. Within each instance, all databases will be managed by default, but individual databases can be ignored by applying a proper filter tool. For convenience, new or removed databases are discovered and monitored automatically and show up in the service tree.

We do not discover new instances; this configuration is left to the user.

The DB2SPI monitors all instance-specific log files and processes separately and provides detailed information about the instances and databases where problems have been detected.

Individual databases belonging to a monitored instance can be left out from monitoring with a selection process, for example, to omit databases from the management, like a test database or one under development.

Note that the DB2SPI collects performance data for all DB2 instances configured on a given DB2 server and for all databases making up these instances. This can generate a significant amount of data. For example, the DB2SPI collects data for more than 130 metrics from each enabled database in each individual DB2 instance. The data collected is kept in the MeasureWare (OV Performance Agent) or embedded (CODA) database for a defined period before they are removed automatically. The usage of OVPA / CODA can be switched on and off with a configuration parameter or from the OVO application desktop.

## Limitations

Depending on the wealth of metric data collection, the number of databases monitored on one system and the power of that system, some additional CPU load may be observed.

# 5 Before You Begin

This section provides important information that you should use to ensure that the systems on which you intend to install the HP OpenView SMART Plug-In for DB2 are suitable *before* you attempt to install the software. The section comprises the following topics:

- DB2SPI Basic Architecture
- Installation Prerequisites
- Disk Space Requirements
- Memory (RAM) Requirements
- Performance Data Collection Tools
- Self-Healing Collector

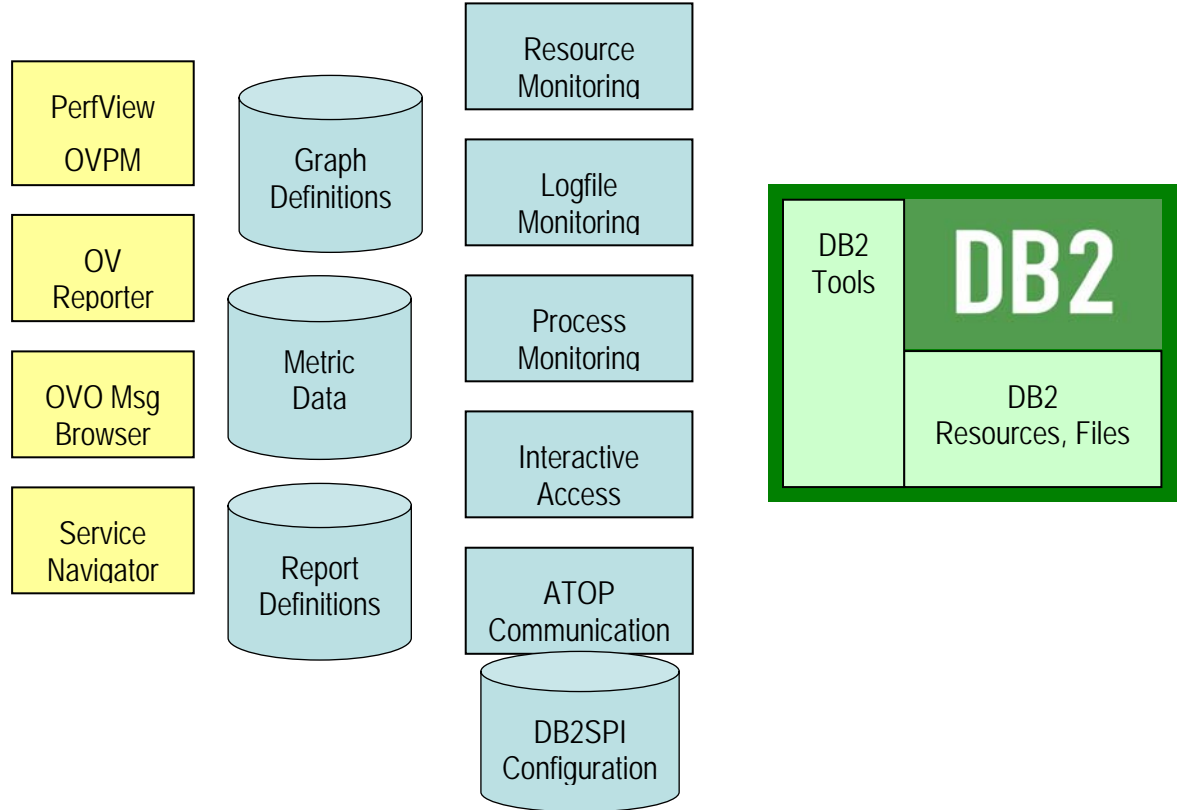
## DB2SPI Basic Architecture

### Building Blocks

The DB2SPI consists of various components that are installed or distributed in the managed environment:

- OVO-intrinsic components like templates (policies)
- Perl scripts, database access libraries and a few binary programs on the management server and the managed nodes
- A common communication interface for application interaction (ATOP, **A**pplication **T**unnel for **O**perations) on the management server, the managed nodes, OVO/Unix Java display stations and OVO/Windows management consoles.
- Reports are provided for the OV Reporter to enable efficient service reporting of performance data and database availability. Note, that the OV Performance Agent (OVPA, formerly known as MWA) or the embedded performance agent (CODA) is required for that.

**Figure 1: Components of the DB2SPI**



## Installation Prerequisites

This section describes the various platforms and software versions supported by the DB2SPI. Make sure that a supported version of OVO is installed and running on both the OVO management server and the OVO managed node and, in addition, that a supported version of DB2 is installed and running on the DB2 server.

This includes the aspects:

- DB2 versions and platforms supported
- OVO platform versions
- Perl on both the management server and the managed nodes
- Disk space and memory requirements
- Performance data collection tools

## DB2 Versions

The DB2SPI B.03.02 supports DB2 UDB version 8.1 and 8.2.

The DB2SPI supports the DB2 Extended Enterprise Edition and the Enterprise Server Edition. For other editions please refer to the respective support matrix.

## DB2 Server Operating Systems

The DB2SPI supports DB2 servers running on the following operating systems:

- AIX 5L (5.1, 5.2, 5.3)
- HP-UX 11.0, 11.11, 11.23
- Solaris 8, 9, 10
- Linux 2.4
- Windows 2000, Windows 2003 Server

The versions of the DB2 server operating systems depend on the OVO agents that are installed on these systems and can be determined from their support matrix. (Please contact your Sales Representative for details).

DB2 is also supported by the DB2SPI on high availability versions of these operating systems where applicable. By integrating the DB2SPI into the switch-over process of DB2 packages (a.k.a. resource groups) a seamless monitoring can be achieved.

Note, that due to the way OVO agents deal with nodes (node-centric agent operation), each physical DB2 system will appear as such, rather than the DB2 packages. This affects all node information in messages and service tree icons.

## Perl on Managed Nodes

On the DB2 server nodes that need to be managed as well as on the management server, Perl is an essential component, because most large parts of the DB2SPI are written in Perl. The only supported and tested version of Perl is 5.6.1 on these nodes, as installed with the OVO agent.

This Perl version is delivered with all OVO agents version 7.x and higher (DCE agents and HTTPS agents) and it is installed automatically when distributing the agent software to the managed nodes.



The Perl 5.6.1 delivered with OVO DCE agents (version 7.x) and HTTPS agents (version 8.x) for AIX managed nodes is not functional. Hence, an AIX Perl needs to be installed separately on AIX nodes.

An agent Perl replacement must be installed, available from the NiCE customer portal. Please see the DB2SPI Release Notes for details.

Note that we do NOT use any other Perl installed and we do NOT interfere with those installations. We stick to the OVO agent Perl and hence those other installations can be maintained independent from the DB2SPI.

**Table 3: VO 7.x & 8.x Agent Perl paths**

Operating System	Path to Perl Executable
AIX 5L	/usr/lpp/OV/contrib/perl/bin/perl (DCE Agent) /usr/lpp/OV/nonOV/perl/a/bin/perl (HTTPS agent)



Operating System	Path to Perl Executable
HP-UX 11.11, 11.23	/opt/OV/contrib/perl/bin/perl (DCE Agent) /opt/OV/nonOV/perl/a/bin/perl (HTTPS Agent)
Solaris 8, 9, 10	/opt/OV/contrib/perl/bin/perl (DCE Agent) /opt/OV/nonOV/perl/a/bin/perl (HTTPS Agent)
Linux 2.4	/opt/OV/contrib/perl/bin/perl /opt/OV/nonOV/perl/a/bin/perl (HTTPS Agent)
Windows	/usr/OV/bin/perl (DCE Agent) /Program Files/HP OpenView/nonOV/perl/a/bin/perl (HTTPS Agent)

## Perl on the Management Server

Some functionality is provided on the management server (Unix or Windows), so the same requirement as for managed nodes also applies to the management server.

As it is a managed node anyway, the same rules will be applied as given above.

During installation of the product, we determine the version of the OVO agent and link ourselves to the proper OVO agent Perl. Note, that this link may become invalid when upgrading the server agent at a later time (e.g. from DCE to HTTPS or vice versa).

## Internet Information Server Settings

When using the user defined metrics (UDM) configuration tool, make sure that the following configuration is set:

The Internet Information Server (IIS) on the OVO/Windows management server must be configured to allow "parent paths" in web addresses.

Note that this is default in IIS up to version 5.0, but the default has changed with version 6.0 and hence may need to be adapted. This is done in the "Administrative Tools" as follows:

- 1 Double-click your computer name in the left pane, and then double-click Web Sites.
- 2 Locate the Web site and directory that houses the ASP application.
- 3 Right-click the application site or directory, and then click Properties.
- 4 Select Home Directory, and then click Configuration.
- 5 Click Options, and then click to select the Enable Parent Paths check box.
- 6 Click OK two times.

## OVO Server Versions

### Unix based OVO

The DB2SPI A.03.00 supports OVO for Unix 7.x and OVO for Unix 8.x on the following platforms:

- HP-UX 11.0, and 11.11 and 11.23
- Solaris 8thru 10.

Please note that this list may change with the support of the respective platforms by HP.

## Windows based OVO

The DB2SPI B.03.02 can be installed in English or German OVO for Windows 7.5 environments.

## OVO Environment Requirements on the Managed Nodes

The DB2 Servers that should be managed with the help of the DB2SPI will in the following be called OVO managed nodes.

The OVO managed nodes need to have an OVO agent installed, as well as the appropriate Operating System templates policies in order to be able to function properly.

The OVO management server must be a managed node itself and have the OVO agent software installed. This is required to make use of the ServiceNavigator (OVO/Unix) and OV Reporter integration. If this requirement is not fulfilled, functionality of the DB2SPI will be limited. It is not necessary to have the management server in a DB2 specific node group.

- With OVO/Unix, only actions and commands of the DB2SPI are required on the management server, no policies (templates) or monitors. They are distributed anyway when performing an "Install and Update Software and Configuration" to the management server after the DB2SPI has been installed. Details about this step will be given later.
- With OVO/Windows, the actions and commands of the DB2SPI that are required on the management server are distributed, when instrumentation is deployed to the management server, after the DB2SPI has been installed. Details about this step will be given later.

As stated earlier, the OVO agent supplied Perl 5.6.1 is essential on both the management server and the managed nodes.

Internal command forwarding requires that the command line buffer of the operating system must at least be 1024 byte. Please use the `ulimit -s` command to verify your command line buffer size.

## Disk Space Requirements

### Space for Binaries and Configuration

The DB2SPI requires hardly any disk space on both the management server and the managed nodes to store programs and configuration data. Though for performance collection larger amounts of data is required.

- about 60 Mb disk space is required on the management server
- less than 5 Mb disk space is required on managed UNIX nodes
- less than 6 Mb disk space is required on managed Windows nodes

### Runtime Data

However, quite some space is required at runtime, particularly when performance monitoring is enabled. The amount of disk space required at run time depends to a large extent on the number of DB2 instances and databases that the DB2SPI is configured to monitor.

An indefinable amount should be expected to be consumed by temporary and log files. However, this should not exceed 2 Mbyte in most configurations.

The DB2SPI also comes with a self-monitoring that makes the user aware of large own log files.

The large quantity of disk space will therefore be used for storing performance data.

To make a rough estimation of the amount of free disk space required by the DB2SPI, assuming that performance monitoring is enabled and the OV Performance Agent is preserving the data it collects for graphing and reporting for one year, you can use the following formula:

- 75 Mbyte for the OV ServiceReporter data collection
- 5 Mbyte x *[number of databases to be managed]*
- 50 Mbyte x *[number of tablespaces to be managed]*

where:

number of databases = total number of databases monitored in all instances on the respective DB2 server

number of tablespaces = total number of tablespaces monitored in all instances and databases on the respective DB2 server

During configuration on a specific DB2 server, the time frame for the data storage can be reduced to one half, one fourth or one twelfth. This keeps six, three or one month months of data available for performance graphing and reporting.

## Memory (RAM) Requirements

DB2SPI will require available RAM as follows:

- 10 Mb on the OVO management server
- 30 Mb on the OVO managed nodes (DB2 servers)

## Performance Data Collection Tools

In order to store metric data collected by the DB2SPI, the DSI2DDF package must be installed on the OVO management server and the respective instrumentation must have been deployed to the managed nodes (the DB2 servers).

## Self-Healing Collector

In order to make use of the HP self-healing services, the respective instrumentation must also be deployed to the managed nodes and the management server.

# 6 Installing the DB2SPI

In this section, you will find information describing in detail the steps you need to perform to install the SMART Plug-In for DB2 separately. Note that when installing from the HP OpenView Application CD-ROM this is mostly automated, but for separate installation (e.g. after download from an FTP site) all the listed steps are required.

This section also describes how to perform the basic, initial configuration of the DB2SPI. This section covers the following topics:

- Installing the DB2SPI Software on OVO for Windows
- Upgrading DB2SPI from an earlier Version
- Configuring the ATOP Communication Layer

## Installing the DB2SPI Software on OVO for Windows

DB2SPI B.03.02 must be installed on the management server via InstallShield. Please perform the following steps:

- 1 Install the DB2SPI by executing the file **DB2SPI\_B0302.msi**. It can be found on the installation CD
- 2 InstallShield will guide you through the installation.

## Verifying Installation of the DB2SPI Software

To verify that the installation of the DB2SPI completed successfully on the OVO for Windows management server, carry out the following steps:

- 1 Open the Windows® "Control Panel" and use the "Add/Remove Programs" tab to display the list of installed software. You should find the following entries:  
  
**DB2SPI**
- 2 Check that the ATOP server process is registered correctly a service. You can do this by opening the "Control Panel → Administrative Tools → Services". You should see the following entry in the list of installed services:  
  
**ATOP2 Server Service**
- 3 Check that the elements listed in are present in the OVO/Windows Console GUI:

**Table 4:DB2SPI Components in OVO for Windows**

OVO Component	OVO Component Name
Node Groups	DB2-AIX
	DB2-HPUX
	DB2-SOLARIS

OVO Component	OVO Component Name
	DB2-LINUX
	DB2-WINDOWS
Tool Groups	DB2
	DB2SPI Admin
User Roles	DB2 Operator
	DB2SPI Admin
Policy Groups	DB2SPI

## Upgrading DB2SPI from an earlier Version

Due to major reconstructions in the metric collection and additional features, the upgrade process must be done by de-installing the earlier version and installing DB2SPI B.03.02. Unfortunately all configuration and metric data will be lost in this process.

For de-installation please refer to the relevant chapter of this manual and then come back here for instructions for the installation procedure.

## Configuring the ATOP Communication Layer

The DB2SPI uses a communication layer of its own for the execution of input / output applications on the managed nodes. This layer is the Application Tunnel for Operations (ATOP).

It consists of two parts:

- 1 The ATOP server is installed on the OVO management server and the management consoles.
- 2 The ATOP client is installed automatically on the managed node when deploying the DB2SPI scripts (instrumentation).

In order to work correct, you have to make sure that the configuration is consistent between all three types – management server, managed nodes, management consoles.

This is achieved automatically for the ATOP client on the managed nodes when distributing the DB2SPI to them, and the management consoles also get a default configuration with the installation of the ATOP service.

### ATOP Server Setup

#### Terminal Server Usage

Although ATOP does not support Terminal Services in general, it may be used under the right circumstances.

In a separate Whitepaper we describe how to open a remote session on the OVOW server that will pass on all windows opened on the OVOW server including ATOP windows. The main issue is that remote sessions will pass on most windows but not ATOP windows. To get ATOP windows it is necessary to open a **console session** using the “/console” parameter with the call of the Remote Desktop client on the Connecting Windows client.

Please refer to that document, which can be found on the NiCE customer portal server.

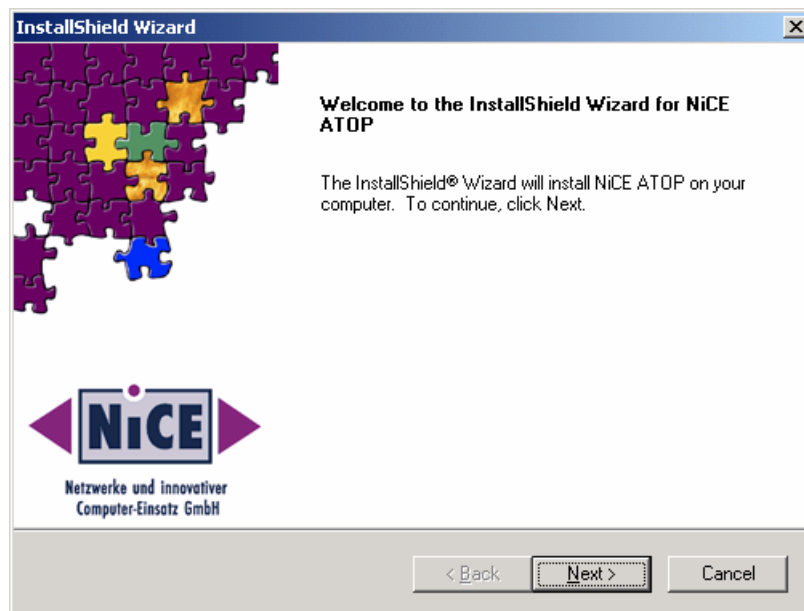
## ATOP on the OVO/Windows Management Server

ATOP server is automatically set up as a Windows® service on the management server when ATOP is being installed (see "Installing the DB2SPI Software on OVO for Windows" on page 20). This means, that the DB2SPI tools can be executed from the OVO/Windows console on the management server. A separate installation step must be performed on OVO/Windows console stations, where only the OVO/Windows console was installed (see "Enabling the OVO/Windows Console Integration" on page 24).

► Terminal Server based installation is currently not supported for ATOP

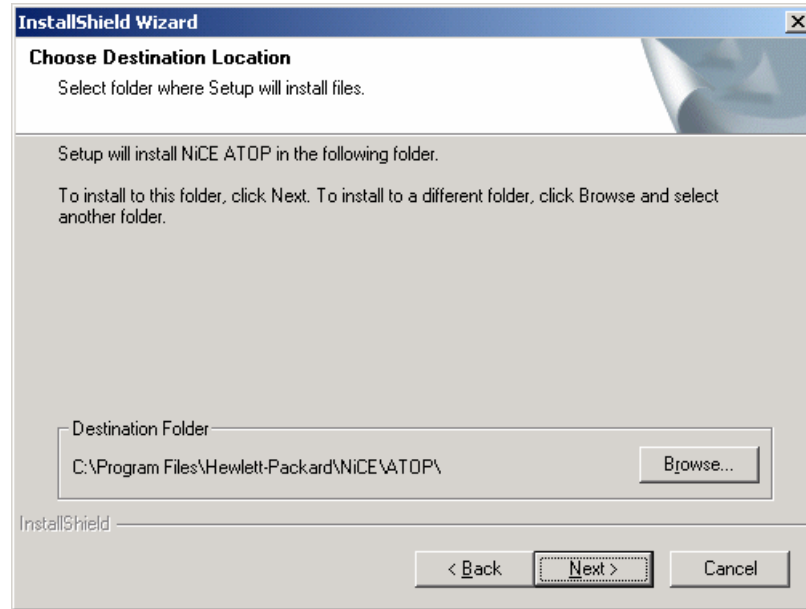
The installation process itself is done via InstallShield and you simply follow the instructions given during the setup. You have to accept the license agreement to continue when asked for. However, ATOP usage is covered by the license of the DB2SPI itself.

**Figure 2** InstallShield window to set up ATOP



We are installing the ATOP Java GUI in the same branch as the OVO Java GUI to indicate the strong relation between them. You cannot operate ATOP without the OVO Java GUI.

**Figure 3: Selection of destination folder**



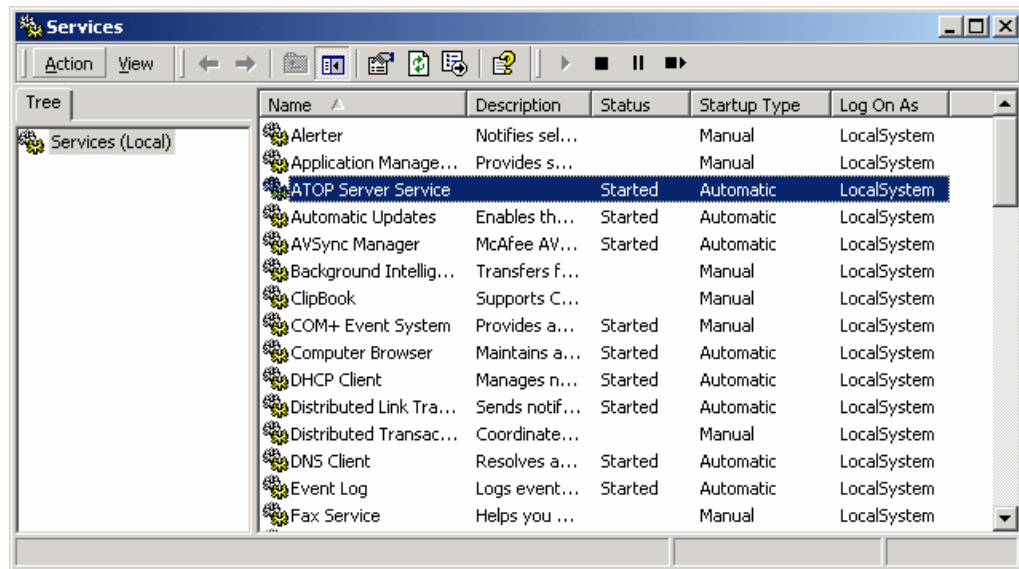
Upon completion of the installation, a final screen showing the success of the installation is displayed.

## Verification of Installation

In Microsoft Windows® environments, an ATOP service is added to the system, which is started automatically with the system startup. It acts as the communication access point for applications requesting input/output on the Java GUI station.

From the Start menu, access "Settings → Control Panel → Administrative Tools → Services". You should find an entry named "ATOP Server Service" as shown in the following picture:

Figure 4: ATOP server service on Windows



## Enabling the OVO/Windows Console Integration

The DB2SPI supports full application interaction in the OVO/Windows Console environment with the embedded ATOP technology. However, since it is not a component of the OVO/Windows Console itself, a Windows service and some programs need to be installed on the OVO/Windows Console station.

- ▶ ATOP must be installed on the OVO/Windows Console stations (Console only installations) in order to use DB2SPI supplied tools.
- ▶ Terminal Server based installation is currently not supported for ATOP.

The communication is set up on the OVO/Windows management consoles via InstallShield. Please perform the following steps:

- 1 Install the DB2SPI by executing the file **DB2SPI\_Console\_B0302.msi**. It can be found on the installation CD
- 2 InstallShield will guide you through the installation as well.



# 7 Getting Started

This chapter gives a brief outline for the experienced OVO user of the steps required to get the DB2SPI up and running quickly in most environments. To set up the DB2SPI and see the first messages in the OVO message browser, you need to carry out the following high-level steps, each of which is described in detail in the sections that follow:

- Setup Steps for OVO/Windows
- Installing DB2SPI Licenses
- OVO Administrative Tasks
- Configuring DB2 Instances
- Distributing the DB2SPI Templates (Policies)

## Setup Steps for OVO/Windows

- 1 Installing DB2SPI Licenses on the Management Server
- 2 Before deploying any DB2SPI components to the managed nodes, you need to install the DB2SPI licenses for your environment on the management server.
- 3 When installing the DB2SPI as an HP OEM product, a generic license is installed automatically.
- 4 Assigning DB2SPI Administrator Responsibility
- 5 In this step, you configure one or more OVO operators in such a way as to allow them to see DB2SPI-related messages, typically used for the self-management of the DB2SPI, and use DB2SPI administration applications.
- 6 Assigning Operator Responsibility
- 7 In this step, you configure the appropriate OVO operators in such a way as to allow them to see DB2-related messages generated by the DB2SPI.
- 8 Preparing the Management Server Utilities
- 9 In this step, you set up the central components of the DB2SPI located on the management server to process the automatic service tree updates.
- 10 Distributing the DB2SPI Instrumentation and Configuration Items
- 11 In this step, you distribute the DB2 management instrumentation and configuration provided with the DB2SPI to the DB2 servers, which are now OVO managed nodes.
- 12 Configuring DB2 Instances
- 13 In this step, you configure the DB2SPI to recognize the DB2 instances present on the DB2 servers you want to manage with OVO.
- 14 Adding Nodes to Node Groups
- 15 In this step, you add the DB2 servers you want to manage with OVO to the appropriate DB2 node groups.
- 16 Assigning DB2SPI Policies (Templates) to individual Nodes

In this step, you may assign the DB2SPI policies to individual DB2 servers you want to manage with OVO rather than adding those nodes to the predefined node groups.

## Installing DB2SPI Licenses

When delivered via HP's Application CD, two licenses are required – one in order to install it permanently on the OVO management server and one per managed node for the execution of the SPI code.

The former is obtained from HP as described in the `SPI_CD_Install.pdf` document; section "How to Obtain a SPI License/Password".

The latter are node-specific runtime licenses that must today be obtained from the manufacturer of the product, NiCE GmbH in Germany. The installation is described next.

## Runtime License Installation

Upon initial installation of the DB2SPI, no runtime licenses are installed as the license files are not part of the product. The DB2SPI binaries are delivered without any runtime license.

Runtime Licenses can be obtained from NiCE as described in "How to obtain Runtime Licenses" on page 141.

This section explains how these licenses can be activated initially with the DB2SPI after installation.

Even for the initial 60 day trial period you need to install a runtime license explicitly. However, this is a very simple step during the installation and described in detail here.

Make sure you have placed the DB2SPI License Update File in a common folder (directory) on the management server.

On OVO/Windows systems, this will typically be the `C:\TEMP`.

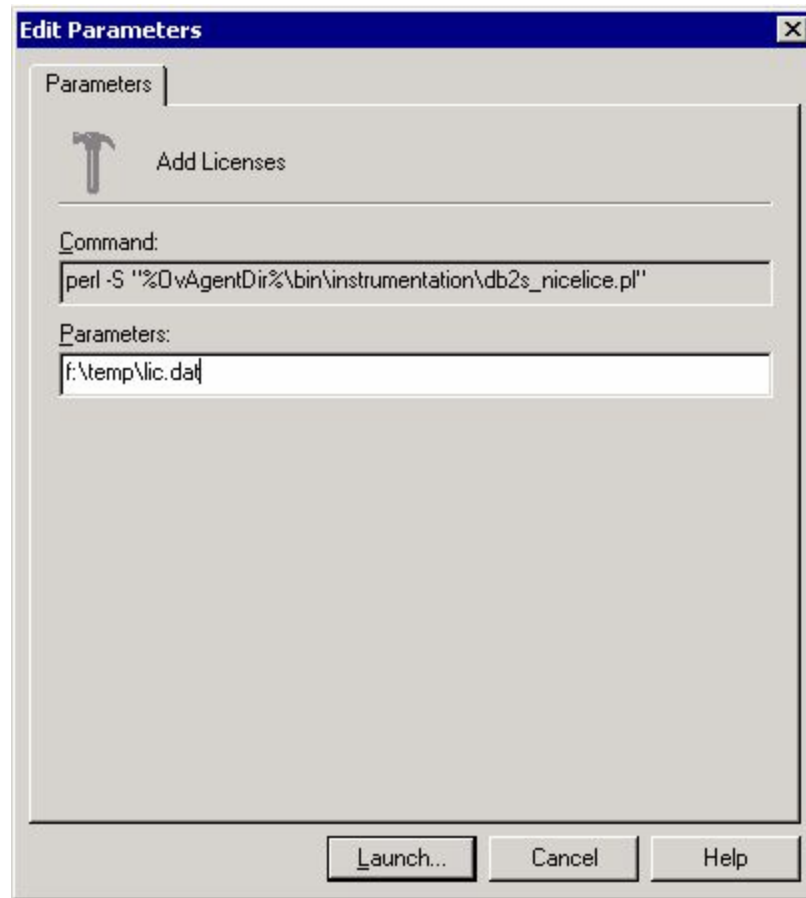
Note that the DB2SPI cannot be operated without a valid runtime license installed on each node. The process of obtaining, installing and maintaining licenses is simple and mostly automatic.

## Installing Licenses in OVO/Windows Environments

To put the runtime license in the proper directories for deployment:

- 1 In the OVO/Windows GUI, execute the "Add Licenses" tool from the "DB2SPI Admin" tools group.
- 2 In the window popping up, you need to specify the License Update file with full path information that you placed in a common folder on the management server.

**Figure 5: Add DB2SPI License into OVO/Windows**



- 3 Then press "OK" to start the process.

An application output window will appear showing the progress of the license installation, You may close that window when the installation has completed.

Figure 6: "License Add" Output

```
ATOP Window - Press ^C to terminate the application
In order to install licenses you have to accept
the license terms for the DB2SPI.
Do you want to read the license terms for the DB2SPI [yn]? y
*****
* DB2SPI License Terms *
*****

This software end user license agreement is a legal agreement between
you and NiCE GmbH. It provides a license to use the software and
contains warranty information and liability disclaimers.
By installing the software and using the software, you are confirming
your acceptance of the software and agreeing to become bound by the
terms of this agreement. If you do not agree to be bound by these
terms, then uninstall the software from your computer.

1. Ownership
1.1. The license gives you limited license to use the Software.
    NiCE GmbH and its suppliers retain all right, title and interest,
    including all copyright and intellectual property rights, in and to,
    the Software and all copies thereof. All rights not specifically
    granted in this license agreement, including Federal and
    International Copyrights, are reserved by NiCE GmbH and its
    suppliers.

Press RETURN or Q to quit ...q
Do you accept the license terms for the DB2SPI [yn]? y
Done with ibm/rs6000/aix/monitor
Done with sun/sparc/solaris/monitor
Done with hp/s700/hp-ux10/monitor
Done with hp/s700/hp-ux11/monitor
Done with hp/s800/hp-ux10/monitor
Done with hp/s800/hp-ux11/monitor
Done with hp/pa-risc/hp-ux11/monitor
Done with linux/intel/linux24/monitor
Done with linux/intel/linux22/monitor
Done with ms/intel/nt/monitor
Done with hp/pa-risc/hpux1100/monitor
Done with hp/ia64/hp-ux11_32/monitor
Done with hp/ipf32/hpux1122/monitor
Done with sun/sparc/solaris7/monitor
Done with ms/x86/winnt/monitor
Done with linux/x86/linux24/monitor

Finished update of DB2SPI licenses. You need to deploy them to the managed nodes now.

Press any key to close the window ...

lassa.nicelab.de 15.250.250.26 /opt/OV/db2spi/bin/db2s_start db2s_nicelice.pl /tmp/beta_0300_200!
```

The license installation requires that the NiCE License Conditions are accepted.

Before any license is installed, we therefore

- Ask if the license conditions shall be shown (possible answers: "y" or "n")
- Ask if the license conditions are accepted (possible answers: "y" or "n")

The display of the license conditions is paged and can be aborted at every page break inserted automatically.

The license(s) can only be installed if the conditions are accepted. If you say "n" (no) when asked for the acceptance of the conditions, no license will be added to the instrumentation for later deployment.

You may close this window when the installation has completed.

## OVO Administrative Tasks

### Assigning DB2SPI Administrator Responsibility

The installation of the DB2SPI adds two new, DB2-specific user profiles to the OVO user profile bank, namely: the DB2SPI Admin Profile and the DB2 Operator Profile. You can use the DB2SPI Admin Profile to create a new OVO user whose role it will be to manage the DB2SPI itself.


Alternatively, you can use the DB2SPI Admin Profile to expand an already existing operator's responsibilities to include the management of the DB2SPI. This OVO user will then be able to see all messages from all nodes in any DB2 node group with the message group DB2SPI.

Note, that the management of the DB2 databases is performed via the DB2 operator profile described in "Assigning DB2 Operator Responsibility" on page 29.

#### Creating a new DB2SPI Administrator in OVO/Windows

To create a new DB2SPI administrator using the DB2SPI Administrator user role:

- 1 In the OVO/Windows Console, open the "User Roles Editor".
- 2 Select the "DB2SPI Administrator Role" and click on "Properties".
- 3 In the "Users" tab you can now assign this role to certain users. Click on the "Add" button and select the user you want to assign this user role to. Click on "Add", then on "OK".

 Note: You can only assign a user role to users which are in the HP-OVE-OPERATORS user group (see also OVO/Windows documentation)

### Assigning DB2 Operator Responsibility

You can now use the DB2-specific user profile to create a new OVO user whose role it will be to manage the DB2 servers. Alternatively, you can use one of the DB2-specific profiles to expand an already existing operator's responsibilities to include the management of the DB2 servers. This enables the operator to see all messages from all nodes in any DB2 node group with the message group DB2.

#### Creating a new DB2 Operator

To create a new DB2 operator using the DB2SPI Operator user role:

- 1 In the OVO/Windows Console, open the "User Roles Editor".
- 2 Select the "DB2SPI Operator" Role and click on "Properties".
- 3 In the "Users" tab you can now assign this role to certain users. Click on the "Add" button and select the user you want to assign this user role to. Click on "Add", then on "OK".



You can only assign a user role to users which are in the HP-OVE-OPERATORS user group (see also OVO/Windows documentation).

## Adding Nodes to Node Groups

The DB2SPI comes pre-configured with a set of platform-specific node groups for the DB2 servers. These node groups are automatically assigned to the appropriate DB2 template groups during the installation and initial configuration of the DB2SPI. In this step, you only need to add the DB2 servers to the appropriate operating-system-specific nodes group, namely:

- DB2-AIX
- DB2-HPUX
- DB2-SOLARIS
- DB2-LINUX
- DB2-WINDOWS

### Adding Nodes to DB2 Node Groups

For OVO/Windows this step has to be performed after “Configuring DB2 Instances”. See “Policy Deployment with OVO/Windows”.

This is because when adding a node to a node group the policies are not only assigned, but automatically deployed.

## Assigning DB2SPI Policies to individual Nodes

Usually, you will have all your DB2 servers in the appropriate default node groups as described in “Adding Nodes to Node Groups” on page 30. However, you may also want to assign the template groups (or even individual templates) to a specific DB2 server. If there is no need to add individual nodes, you may proceed with the next chapter.

### Individual Assignment

For OVO/Windows this step has to be performed after “Configuring DB2 Instances”.

See “Policy Deployment with OVO/Windows” on page 40.

## Preparing the Management Server Utilities

A few tools are required on the OVO for Unix management server for processing messages upon their arrival or to execute applications centrally.

Since these auto-actions and applications are launched via the OVO agents, the management server must be a managed node itself. So, in order to activate this functionality, the list of actions and commands must be updated on the management server after the DB2SPI has been installed.

### Preparing an OVO/Windows Management Server

To do so, just right-click on the management server in the Console Tree and select "All Tasks → Deploy Instrumentation". You need to deploy

- Action
- Command

- DB2SPI (this includes ATOP)
- SHS Data Collector

## Distributing the DB2SPI Configuration Items

When working with DB2 installed in a cluster environment, you have to perform the following distribution for all nodes belonging to the cluster, regardless if DB2 is currently executing on them or not.

### Setup of Managed Nodes

In order to activate the functionality provided with the DB2SPI, you need to deploy the instrumentation to the managed nodes which host the DB2 servers.

To do so, right-click on the managed node (DB2 server) in the Console Tree and select "All Tasks → Deploy Instrumentation". You need to deploy

- Action
- Command
- Monitor
- DB2SPI (this includes ATOP)
- SHS Data Collector
- SPI Data Collector



You should not distribute the DB2SPI templates at this point in time to a DB2 server. This is because the DB2SPI is able to recognize and manage multiple DB2 instances and you need to configure DB2SPI components to recognize the multiple instances before you activate monitoring on the DB2 servers by distributing the DB2SPI templates.

If you accidentally distribute the DB2SPI templates, undo it. For this purpose, de-assign the node from the DB2SPI node group, re-distribute templates and then start over.

Alternatively, you may also launch the tool "DB2SPI Disable" to stop all OVO agent related activities

## Configuring DB2 Instances

In this section, you use the DB2SPI administrator's application "Config Setup" to tell the DB2SPI, which subset of the DB2 database instances are to be monitored with OVO. The following aspects will be described:

- Preparatory Steps to Manage DB2 Servers in Clusters
- Instance Configuration Tool
- Distinctions between UNIX and Windows Nodes
- Configuration Workflow
- Integration into Switch-Over Process for DB2 Clusters

Due to the determination of the DB2 version during this configuration process, the database must be up and running.



- Before starting the configuration, make sure that DB2 is up and running.
- For all instances to be managed the "START DATABASE MANAGER" must have been given

## Preparatory Steps to Manage DB2 Servers in Clusters

The DB2 server can be operated either standalone or in a cluster. For standalone configuration you may safely ignore this section.

The DB2SPI can support a DB2 cluster installation with little effort in preparing the managed node appropriately.

### UNIX Managed Clusters

On UNIX clusters, the following preparations must be done:

- Create a directory `/var/opt/OV/db2spi` (HP-UX, Solaris, Linux) resp. `/var/lpp/OV/db2spi` (AIX) on the shared disk. This directory will later contain all the shared runtime data (log files, metric stores etc.)
- Create a directory `/etc/opt/OV/db2spi` on the shared disk. This directory will later contain all the configuration data for the DB2SPI operating.

If this preparation has been done, the configuration described next must be done on one node only. However, this node must currently host the DB2 server software package. Configuration data as well as runtime data are shared between the nodes of the cluster.

### Windows Managed Clusters

On Windows clusters, data disk sharing in the OV directory trees is currently not supported.

Therefore, the configuration described next must be done on each node of the cluster while the DB2 server resource group is currently active on it.

## OVO Agent Requirement on Windows Nodes

A critical issue may be related to Windows security policies and the configuration of the OVO agent. As we have noticed, the 'system' account and therefore the OVO agent is unable to logon as the respective DB2 administrative user. As a result, DB2SPI's "Config Setup" tool cannot determine the information required from DB2 UDB. You need to check the following user rights assignments on the Windows managed node. This can be done by the MMC snap-in `secpol.msc` -- open up a 'Run' Dialog via Start-Menu and enter 'secpol.msc' here. On the left hand of the dialog you'll find the respective element under 'Local Policies-->User Rights Assignment'. Please verify that the 'System' account under which the agent is running is listed in the 'security setting' field.

The OVO agent ('system') account should be allowed to:

- Act as part of the Operating System
- Bypass traverse checking
- Create a token object
- Replace a process level token

Additionally, the DB2 administrative user must have the right 'log on as a service' assigned.



## Instance Configuration Tool

To tell the DB2SPI which DB2-database instances to monitor:

- Select the DB2SPI Admin "Config Setup" Tool in the Console Tree ("Tools → SPI for DB2 → DB2SPI → DB2SPI Admin")
- Double-click the "Config Setup" tool in the list of tools that are in the DB2SPI Admin tool group
- Select the node (DB2 Server), where you want to configure a DB2 Instance and start the execution of the tool.

## Distinctions between UNIX and Windows Nodes

The DB2SPI can recognize and manage different DB2 instances running on a single DB2 server. In general, the setup is very similar on both platforms. However, due to the way how users are set up for DB2 in the UNIX and Windows world, some minor differences need to be considered.

If you want to be able to access a DB2 instance later, you will need the following information from the DB2 server:

A DB2 administrator responsible for the respective DB2 server must provide the information about the various DB2 accounts listed.

- Administration User (on UNIX based DB2 servers)
- Administration Server and password (for Windows DB2 nodes only)
- On Windows based DB2 servers, the user is asked for the name of the DB2 installation user (or any other user who is accepted by DB2 and allowed to perform the needed operations). In addition, the password for this user is asked (shown in plain text on the window). However, it is then stored in encrypted form in the DB2SPI instance configuration file for later access to the databases.
- Instance User names (Unix only)

On Unix, the application `Config Setup` requires to specify the instance user accounts related to each instance and checks the validity of the entry.

The DB2SPI switches to the instance user environment in order to perform all operations upon DB2; some of them require full control of the instance that can only be guaranteed by the instance owner. He may be set up with any kind of command shell.

At a later time, you may execute the tool `Instance List` from the DB2SPI `Tools` group to check which instance information has been configured.

Although the DB2SPI provides an auto-discovery of the instances available on the DB2 server, there is no automatic monitoring enabled for them. The user has to decide about the instances that need to be monitored.

## Configuration Workflow

The configuration of the managed instances and databases is an important step on each DB2 server. Normally, this is executed only once only after proper planning what is to be managed and what not.

We therefore describe all steps in great detail.


- ▶ At the end of this section ("Configuration Setup " on page 36) you find a log that we recorded during a setup session and that may help you to see the flow at one glance.

As the very first step you have to decide about the language of your installation. A list is shown with the languages supported and you may select one of them.

### Automatic Checks and Preparations

When executing the `Config Setup` tool, it first checks if there are any DB2SPI policies active. If so, they are all disabled, because we cannot establish or replace the configuration while they are running.

We also check if a DB2SPI license file is available. If no license file should be found on the managed node, the setup application terminates prematurely. This is done to avoid useless entry of the data listed next, if the user should have forgotten to run "License Add". However, at this point in time we do not check the validity of the licenses stored there, only the existence of the license file.

 This is also the time when the DB2SPI license is checked. The setup script terminates without discovery of log files, setup of performance collection, replication etc. if there is no valid license found.

### Configure Database Edition

After this check you get you must specify the type of DB2 UDB you have installed; this helps the DB2SPI to monitor the processes that are specific to a particular DB2 version. Enter

```
E           if you have an Enterprise Edition not using DPF
ESEprim    if you have an Enterprise Server Edition (DB2 8.x) an this is the
           catalog partition and DPF is used.
ESEsec     if you have an Enterprise Server Edition (DB2 8.x) secondary
           partition and DPF is used.
```

These distinctions are necessary to determine the list of processes that needs to be monitored.

Please note also, that for secondary nodes in EEE / ESE environments not all performance metrics can be collected. Hence performance monitoring for ESE instances should only be done on the primary nodes.

### Configure Instances

After the configuration of the database edition a numbered list of available instances on the DB2 server.

In a dialogue, select those instances by number that you want to be managed.

The selected instances are shown once again and a confirmation is requested if the selection is correct. If not, the list is dropped and a re-selection is possible.

If you are satisfied with the list, enter "y" when asked for correctness.

For UNIX managed nodes, each instance requires the entry of an instance user as defined by DB2 when creating the instance.

For both platforms, you may select databases that shall be omitted from monitoring. When asked if any database should be omitted, just enter "y" or "n".

In case you decided to exclude one or more of them by entering "y", each database available in the respective instance is shown and you may decide if this database is to be excluded or not.

Answer "y" (yes) if you want exclusion (no messages, no performance data from this database)

Answer "n" (no) if you want it to be managed.

### DB2 Replication Monitoring

The tool then asks if DB2 Replication should also be monitored.

If answered "n", the respective DB2SPI component is disabled. Please note, that it cannot be switched on at a later time without doing the complete configuration again.

If answered "y", a discovery is performed for all "Capture" schemata and "Apply" qualifiers defined on the node of our server. Configuration information is stored for the log file monitoring of DB2 Replication at a later time.

### Discovery of Database Version and Log Files

After these user actions, the DB2SPI continues to discover various additional configuration data automatically and directly from DB2:

- DB2 version
- location and name of diagnostic log files
- location and name of administrative log files
- SQL capture and apply paths if SQL replication is setup and monitoring desired

Note, that the first database of the first instance on the managed node must be available to perform the determination of the database version, as we try to connect to it for this purpose. If a message appears stating that the version could not be determined, please make sure that this requirement is met and redo the configuration.

After successful completion of DB2 instance setup, the application `Config Setup` lists some additional activities that it has performed and then attempts to send a message to the OVO message browser informing the OVO user that the DB2 instance setup has been successful.

Note that the following error may be displayed if an `opcmsg` template is not yet present on the managed node hosting the DB2 server.

```
The ITO message command is not configured on this system. Contact your ITO Administrator to configure it: (OpC30-913).
```

This is just a warning message: the `opcmsg` template will be installed during the installation of the DB2SPI templates.

### Some Notes on Database Discovery

With the "`Config Setup`", we have defined the instances that will be monitored completely, i.e., all databases found in these instances are monitored automatically (unless excluded explicitly, as given above).

The DB2SPI discovers new databases automatically and applies the monitoring upon them. This makes it very comfortable to add or remove databases without additional configuration effort of the DB2SPI.

If you want to disable some databases from being monitored you may run the application "`Database Filter`" from the DB2SPI Admin tools application group at any time to define exclusion lists of databases.

The instance configuration and the exclusion lists also determine the elements shown up or omitted in the DB2 branch of the ServiceNavigator display described in "Service Management with OVO" on page 103.

### Data Collection Setup during Instance Configuration

On most platforms, performance metrics can be collected with the MeasureWare agent (MWA; also known as "OV Performance Agent", OVPA) or the embedded performance agent (CODA).



The DB2SPI checks the existence of `ddfcomp` on the managed node. If it should not exist during setup, no metric data will be stored for reporting or graphing.

Make sure to have the DSI2DDF tools installed on the management server and deployed to the managed node before running "Config Setup".

During the configuration of the instances to be monitored the following steps are taken automatically for the setup of performance data collection:

- Determine the availability of the DDF-Tools (i.e. `ddfcomp`) on the managed node.
- If available, set up specific data source descriptions for all configured instances to collect data for both PerfView/OVPM and OV Reporter analysis.
- Shutdown and restart MWA/OVPA (if configured) to make it aware of the new configuration.

If `ddfcomp` cannot be detected, no data collection will take place. Only OVO based metric threshold monitoring will be available. A proper message about the omission of the metric collection setup is provided in this case.

The DB2SPI may collect a vast amount of data from tablespace monitoring in a so-called "drilldown" database. This is especially true for configurations that consist of a large number of DB2 tablespaces (more than 100).

In order to limit this file, the user is asked to select from a 1 / 3 / 6 / 12 month timeframe for the data collection in this drilldown database. For 88 tablespaces, this would result in a disk space requirement of 256 / 512 / 1024 / 2048 Mb.

### Configuration Setup Log

A typical protocol for the performance collection setup during "Config Setup" is shown in the log file following next. .

In this log, all user entries are printed in bold type.

---

Hostname: dengue

```
DB2SPI Instance Setup
=====
```

```
Please wait ...
```

```
This operation may take some time, because we must
synchronize this action with the OVO agent
processing DB2_admlog_unix ...
```

```
processing DB2_diag_unix ...
```

```
processing "DB2_syslog(HP-UX)" ...
```

```
processing DB2_opcmsg ...
```

```
processing DB2_metric_30m_unix ...
```

processing DB2\_metric\_10m\_unix ...

processing DB2\_procmon\_unix ...

processing DB2\_mwalogger\_unix ...

processing DB2SPI\_discover\_svctree\_unix ...

processing DB2SPI\_fs\_adm\_unix ...

processing DB2SPI\_fs\_db2spilog\_unix ...

processing DB2SPI\_fs\_db2spitrc\_unix ...

processing DB2SPI\_fs\_diag\_unix ...

processing DB2SPI\_ownlog1\_unix ...

processing DB2SPI\_svctree\_unix\_auto ...

processing DB2SPI\_svctree\_unix\_upd ...

Please enter the name of the DB2 administrative user

Administration Server: dasusr1

\* Standalone databases:

Is this an Enterprise Edition? Enter E

Is this a Workgroup Edition? Enter W

Is this a Personal Edition? Enter P

\* DB2 7.x Extended Enterprise Edition:

Is this an EEE primary node? Enter EEEprim

Is this an EEE secondary node? Enter EEEsec

\* DB2 8.1 Enterprise Server Edition:

Is this an ESE primary node? Enter ESEprim

Is this an ESE secondary node? Enter ESEsec

>E

DB2 version 8.1 running

Following instances found on dengue

1. db2inst1
2. db2inst2
3. db2inst3
4. db2inst4
5. db2inst5
6. db2inst6
7. db2inst7
8. db2inst8
9. db2inst9
10. db2ins10

Please enter the numbers for the instances you want to monitor  
(separated by space):

1 4 7

The following instances will be monitored:

1. db2inst1
2. db2inst4
3. db2inst7

Is this correct [yn]?>y

Configuration of instance db2inst1

Instance user: db2inst1

Do you want to exclude some databases from being monitored [yn]?>n

Configuration of instance db2inst4

Instance user: db2inst4

Do you want to exclude some databases from being monitored [yn]?>n

```
Configuration of instance db2inst7
Instance user: db2inst7

Do you want to exclude some databases from being monitored [yn]?>n

Do you want to monitor SQL replication [yn]? >n

Collecting names for diagnostic and admin log files ...
Processing instance db2inst1 now ...
Processing instance db2inst4 now ...
Processing instance db2inst7 now ...

Adding performance measurement ...
Processing instance db2inst1 now ...
Processing instance db2inst4 now ...
Processing instance db2inst7 now ...

The application: "db2s_setupinst.pl -init" has terminated.
Please press RETURN to close the window.
```

---

## Integration into Switch-Over Process for DB2 Clusters



This description applies to the DB2 server being managed by "classical" means of OVO, i.e., without applying the "Cluster Awareness" available with HTTPS agents and virtual nodes, as described in the OVO/Unix 8.x documentation.

At this place, we explain the integration of DB2SPI switch-over into the DB2 switch-over process.

When making use of the "virtual node" concept of OVO/Unix 8.x, switch-over is automatically provided by the OVO platform and no specific actions need to be taken by the user.

Running DB2 application packages (a.k.a. resource groups) under cluster control offers a great improvement of availability for DB2.

The functionality of the DB2SPI monitoring a DB2 server must also be switched with the DB2 server; otherwise lots of error messages would be created on nodes where DB2 is currently not running, but the DB2SPI (and the OVO agents) are.

The specific switch-over scripts for the respective cluster administration software therefore need to be extended by adding the following function calls:

- To enable the DB2SPI when a package activation takes place:

```
db2s_db2spi.pl ON
```

- To disable the DB2SPI when a package de-activation takes place:

```
db2s_db2spi.pl OFF
```

You need to make sure that the cluster administration software is aware of the paths of the OVO agent to use this functionality.

## Distributing the DB2SPI Templates (Policies)

After configuring the DB2SPI to recognize the DB2 instances running on the DB2 server you want to monitor with OVO and assigning the DB2SPI templates, you need to distribute the DB2SPI templates to the DB2 servers, as follows.

If the DB2 server is installed in a cluster environment, the policies must be deployed to all physical nodes belonging to the cluster. However, they are activated only when the DB2SPI (and DB2) is active on the respective system.


### Policy Deployment with OVO/Windows

You can deploy policies by doing one of the following:

Add the DB2 server node to the appropriate DB2SPI node group. In this case the policies get automatically deployed to this managed node. This is described in the next section, "Adding Nodes to DB2 Node Groups"

Manually deploy the appropriate DB2SPI policy group or specific policies (depending on the managed node platform). This is described in the section, "Individual Assignment in OVO/Windows"


Deploying the DB2SPI policies to the DB2 server automatically activates monitoring on the DB2 server.

 Note: If you stopped the OVO agents in a previous step, restart them now.

### Adding Nodes to DB2 Node Groups

To add a DB2 server running on HP-UX 11.11 to the correct node group:

- 1 In the OVO/Windows Console, open the "Nodes Editor".
- 2 In the Node tree, drag and drop the node on the DB2-HPUX Node Group.

 Make sure that you had configured the node for the DB2SPI, before you add the node to a DB2SPI node group. Otherwise, you will immediately see some error messages in the message browser for this node (see sections "Distributing the DB2SPI Configuration Items" and "Configuring DB2 Instances" for more information).

- 3 The appropriate DB2SPI policy groups are automatically deployed to the node, after it was added to the DB2SPI node group.



## Individual Assignment

Use the OVO/Windows Console to assign the appropriate DB2SPI policies to the managed nodes (the DB2 servers), as follows:

- 1 In the "Policy deployment" section of the Console Tree, right-click the DB2 Policy group or specific policy you want to deploy and select "All Tasks → "Deploy on".
- 2 Select the node(s) you want to deploy the policies to and click on "OK".

# 8 Using the DB2SPI

This section describes what tools are available to both the DB2SPI administrator and the DB2SPI operator to assist them in the performance of their every-day tasks. The section covers the following areas:

- Components in the OVO Administration Scope
- DB2SPI Administrator Tasks
- DB2 Operator Tasks

This section also describes the day-to-day tasks that a DB2SPI administrator and a DB2SPI operator can expect to carry out:

## Components in the OVO Administration Scope

### DB2SPI Node Groups

During the installation of the DB2SPI software, the DB2SPI adds the node groups listed in **Fehler! Verweisquelle konnte nicht gefunden werden.** to the OVO GUI.

**Table 5: Node Groups**

Node Group	Description
DB2-AIX	Contains all DB2 servers running on the supported AIX platforms
DB2-HPUX	Contains all DB2 servers running on the supported HP-UX platforms
DB2-Solaris	Contains all DB2 servers running on the supported Solaris platforms
DB2-LINUX	Contains all DB2 servers running on the supported LINUX platforms
DB2-WINDOWS	Contains all DB2 servers running on the supported Windows platforms

Note, that the DB2SPI automatically assigns the appropriate template groups to the DB2SPI operating system specific node groups. Consequently, it is not necessary to perform any additional steps to configure DB2 servers apart from adding the DB2 managed nodes to the appropriate, operating-system-specific node groups.

In OVO/Windows, the DB2 Node Groups are just a branch in the "Nodes" part of the console tree as shown in

Figure 7: DB2SPI Node Groups in OVO/Windows

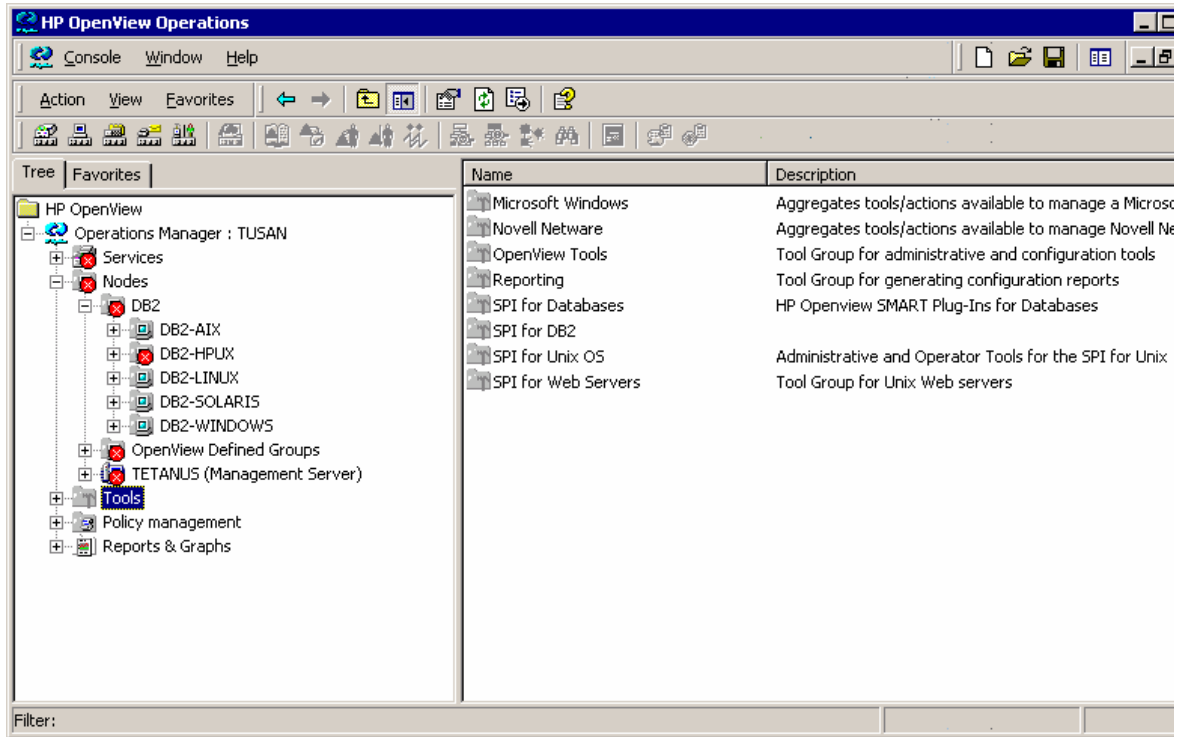
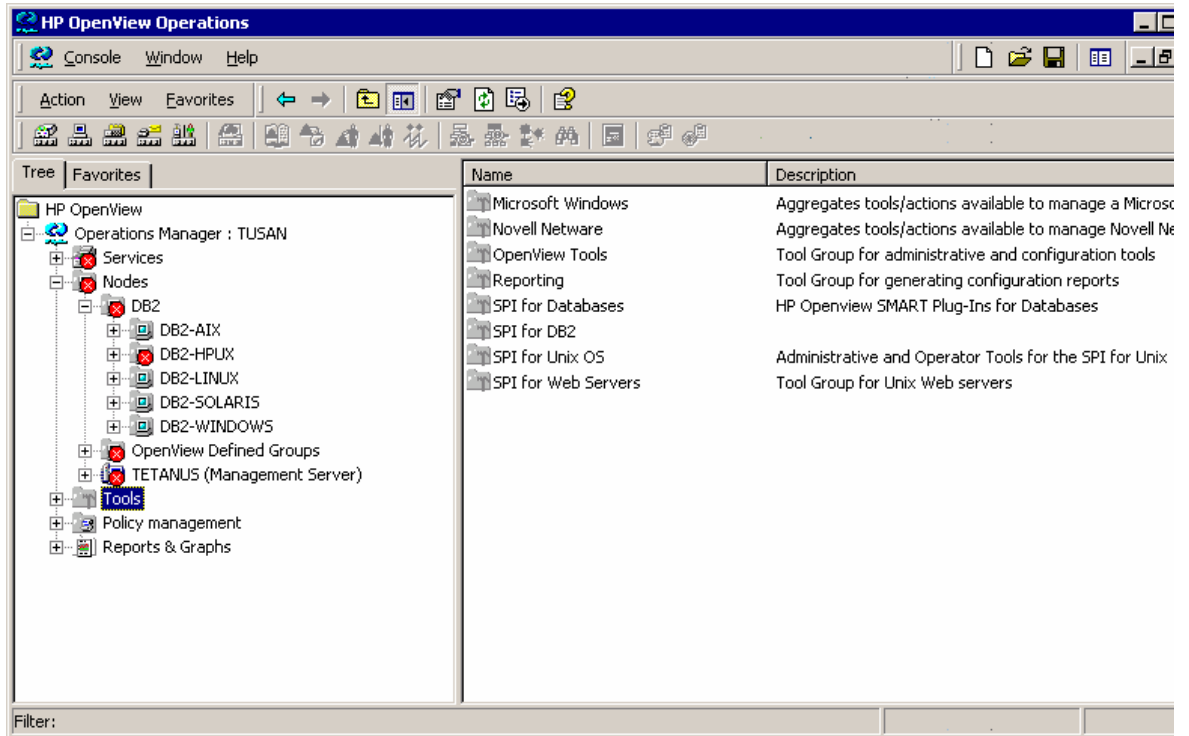


Figure 7: DB2SPI Node Groups in OVO/Windows




## Maintaining DB2SPI Node Groups

The OVO Administrator must make sure that the DB2 servers have been added to the appropriate, platform-specific DB2SPI node groups created during the installation of the DB2SPI.

The DB2SPI installation process automatically assigns the appropriate DB2SPI policies (message-source templates) to the DB2SPI node groups and assigns the DB2SPI appropriate DB2SPI node groups to the default DB2SPI user profiles.

However, this default node-group configuration is not required by the DB2SPI. If you prefer to set up special assignments for your own environment, or need more limited management capabilities, or perhaps simply for test reasons, you can choose to do without the default DB2SPI node groups.

 If you do not use the DB2SPI node groups, you will have to configure the appropriate message-group and template-group assignments manually.

## DB2SPI Tools

During the installation of the DB2SPI software, the DB2SPI adds the tools as applications and application groups shown in the next few tables to the OVO/Unix GUI.

On top level, just two application groups are added that allow a distinction between administrative (DB2SPI Tools) and operational (DB2 Tools) applications.

Opening one of these groups shows up another grouping, holding two "container" symbols that contain platform specific applications.

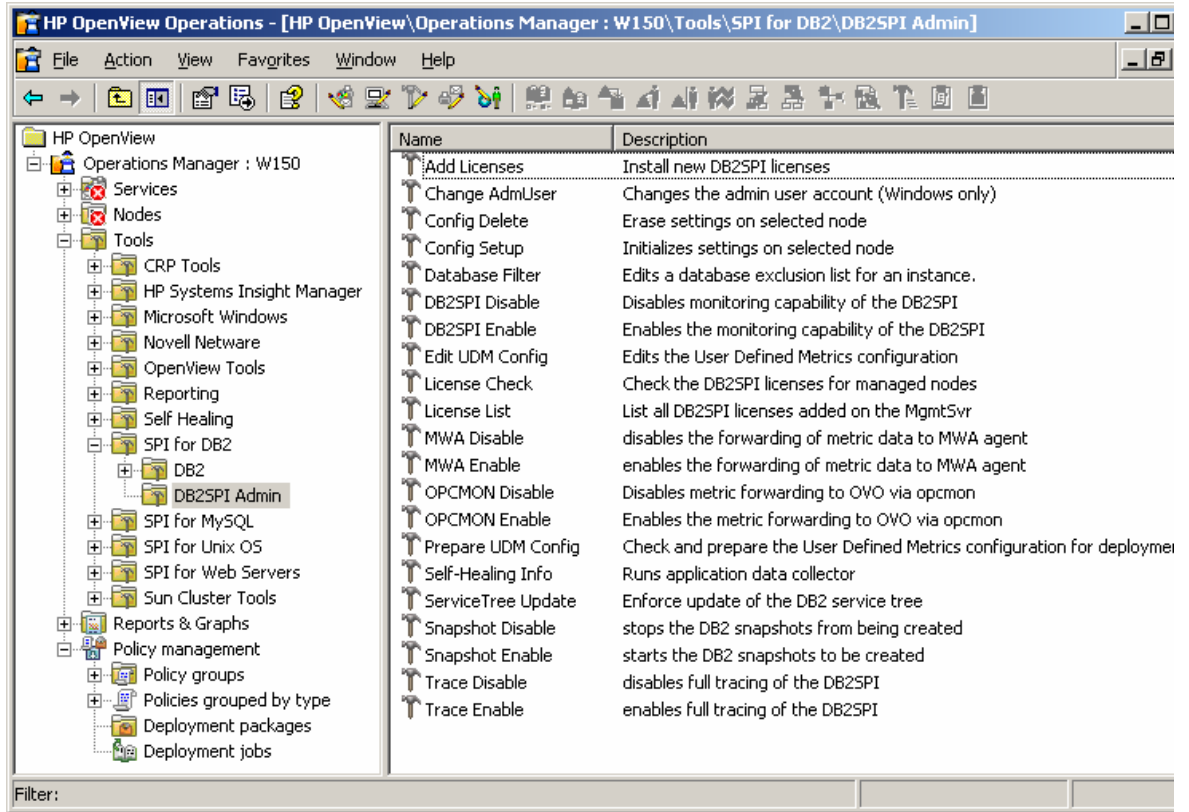
For some, few applications there are differences between Unix- and Windows-based applications, and we distinguish between them in a suffix of the label, (Unix) or (Windows). Please be careful when executing such tools to have the appropriate one for the respective platform.

Figure 8 shows the hierarchy of the application groups in the OVO/Unix application bank. Note, that we have eliminated all other applications to focus on the DB2SPI components here.

### DB2SPI Admin Tools

The DB2SPI Admin Tools application group looks as follows in OVO/Windows:

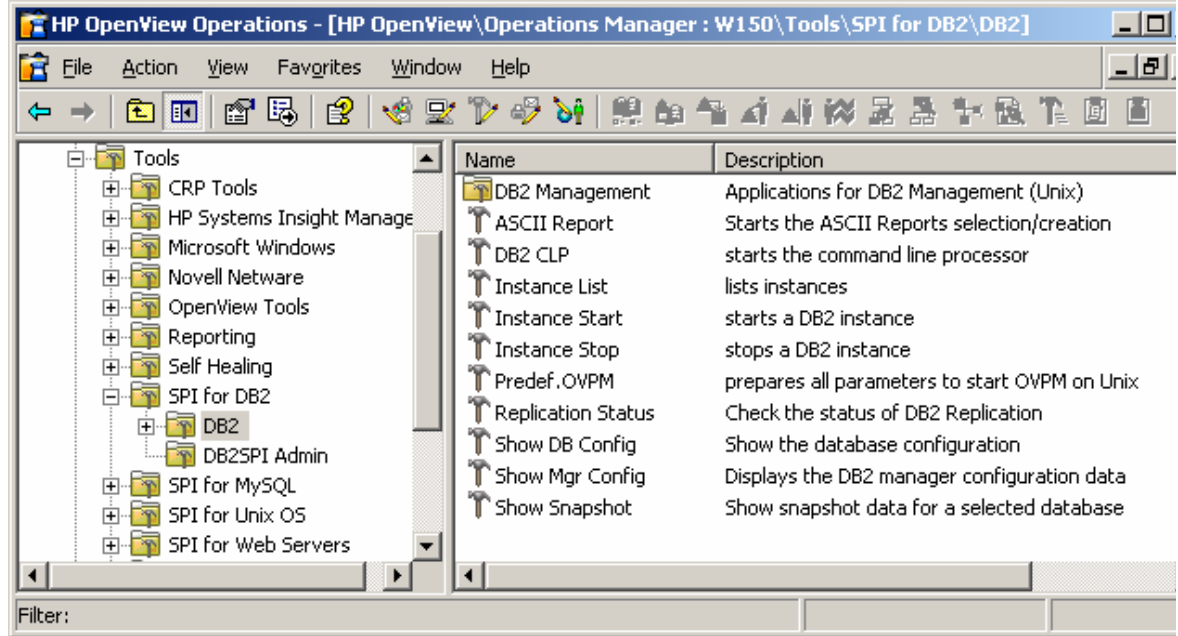
**Figure 9: DB2SPI Admin Tools Group**



## DB2 Tools

The DB2 Tools application group shows the tools that are accessible to the DB2 operator and appear as follows:

**Figure 10: DB2 Tools application group**



The embedded "DB2 Management" group provides a large set of interactive, administrative tools described in "Advanced Management Tools" on page 80.

In Table 6 we list all applications that are available for managed nodes.

**Table 7: DB2SPI Application Groups for managed nodes**

Application Group	Application	Description
DB2 Tools	ASCII Report	Select an area and create drill-down report for metrics of this area Executes the db2 utility on the managed node to enter commands interactively Displays the DB2 manager configuration data
	DB2 CLP	Executes the db2 utility on the managed node to enter commands interactively Displays the DB2 manager configuration data
	Instance List	Lists all managed DB2 instances and databases present on the DB2 server and their monitoring status
	Instance Start	Starts a DB2 instance
	Instance Stop	Stops DB2 instance a
	Predef. OVPM	Create predefined OVPM graphs (OVO/Unix environment only)
	Replic Status Predef.	Check and report the status of DB2 replication

<b>Application Group</b>	<b>Application</b>	<b>Description</b>
	Show DB Config	Display configuration of a selectable DB2 instance / database)
	Show Mgr Config	Display configuration of the DB2 manager
	Show Snapshot	Show metric data for a selectable instance / database
	DB2 Management	Interactive tools that allow administrative tasks on instances and databases
DB2SPI Admin	Change AdmUser	Changes the Admin User account (Windows only)
	Config Setup	Define the instances that need to be managed
	Config Delete	Removes the instance definition file
	Database Filter	Defines database exclusion lists for instances
	DB2SPI Disable	Stop all monitoring of DB2 on the selected node
	DB2SPI Enable	Start all monitoring of DB2 on the selected node
	License Check	Check the DB2SPI license for the managed node
	MWA Disable	Stop forwarding metric data to OVPA/CODA agent
	MWA Enable	Start forwarding metric data to OVPA/CODA agent
	OPCMON Disable	Stop forwarding metric data to OVO agent
	OPCMON Enable	Start forwarding metric data to OVO agent
	Self-Healing Info	Run the application data collector
	ServiceTree Update	Enforce immediate DB2 service discovery
	Snapshot Disable	Stop DB2 snapshot creation
	Snapshot Enable	Start DB2 snapshot creation
	Trace Disable	Turn off extensive tracing of DB2SPI processes (use only for troubleshooting)
	Trace Enable	Turn on extensive tracing of DB2SPI processes (use only for troubleshooting)

**Table 8: DB2SPI Applications executable on OVO management server**

<b>Application Group</b>	<b>Application</b>	<b>Description</b>
DB2 Tools	ServiceTree Assign	Assign the DB2 service tree to yourself (for OVO/Unix only)

Application Group	Application	Description
DB2SPI Tools	License Add	Add DB2SPI licenses to the OVO configuration (no deployment yet)
	License List	List all DB2SPI licenses added on the management server
	Edit UDM Config	Edit the User Defined Metric configuration file
	Prepare UDM Config	Prepare the UDM configuration file for deployment (no actual deployment)

Note, that all these applications are executed in separate windows on the user's display station by making use of either OVO-intrinsic methods or the DB2SPI-intrinsic windowing system (ATOP).

## DB2SPI User Profiles (User Roles)

During the installation of the DB2SPI software, the DB2SPI adds the users and user profiles listed in Table 9 to the OVO GUI.

**Table 10: DB2SPI User Profiles**

User-Profile Name	Description
DB2 Operator Profile	OVO user profile for the DB2SPI user
DB2SPI Admin Profile	OVO user profile for the DB2SPI administrator

The responsibility matrix for the DB2SPI user profiles automatically assigns the message group DB2 and all the DB2 node groups to the DB2 Operator Profile user profile. Similarly, the message group DB2SPI and all the DB2 node groups are assigned by default to the DB2SPI Admin Profile user profile.

The DB2 Operator profile is responsible for :

- all messages with Message Group attribute "DB2" from any node contained in the node groups "DB2-AIX", "DB2-HPUX", "DB2-SOLARIS", "DB2-LINUX" or "DB2-WINDOWS"
- and, in addition, can execute any application in the Application Group "DB2"

The DB2SPI Admin profile is responsible for:

- the entire DB2 Operator profile
- all messages with Message Group attribute "DB2SPI" from any node contained in the node groups "DB2-AIX", "DB2-HPUX", "DB2-SOLARIS", "DB2-LINUX" or "DB2-WINDOWS"
- and, in addition, can execute any application in the Application Group "DB2SPI" (and, implicitly, those of the group DB2 since the DB2 operator profile is embedded)

## Maintaining DB2SPI Users in OVO

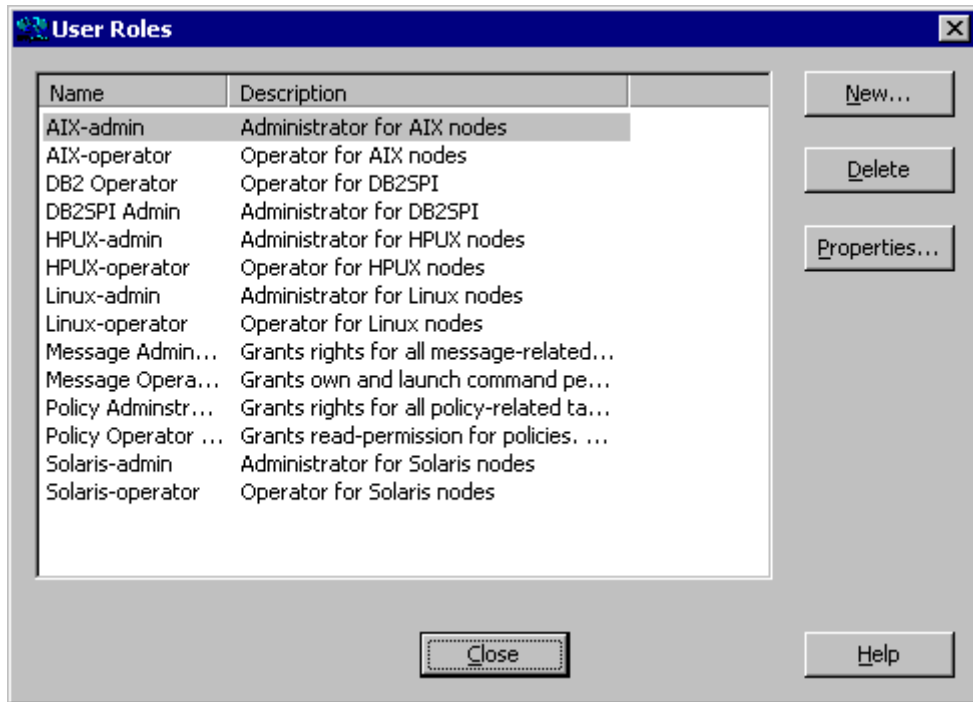
The OVO Administrator is responsible for assigning the DB2SPI user profiles to the appropriate users or using the DB2SPI user profiles to create new OVO users.



## User Roles in OVO/Windows

After the successful installation of the DB2SPI, the User Role Editor shows the DB2 Users Roles as in the following example (Figure 11: The DB2SPI User Profiles).

**Figure 12: The DB2SPI User Profiles**



## DB2SPI Message-Source Templates (Policies)

During the installation of the DB2SPI software, the DB2SPI adds the templates and template groups shown in Table 11 to the OVO Console.

**Table 12: DB2SPI Message-Source Template Groups**

Top Template Group	Template Group	Description
DB2SPI AIX	DB2SPI Base	Base management components for DB2 servers (Unix and Windows)
	DB2SPI Base (Unix)	Common components for all Unix(-like) systems
DB2SPI HP-UX	DB2SPI Base	Base management components for DB2 servers (Unix and Windows)
	DB2SPI Base (Unix)	Common components for all Unix(-like) systems

Top Template Group	Template Group	Description
DB2SPI Linux	DB2SPI Base	Base management components for DB2 servers (Unix and Windows)
	DB2SPI Base (Unix)	Common components for all Unix(-like) systems
DB2SPI Solaris	DB2SPI Base	Base management components for DB2 servers (Unix and Windows)
	DB2SPI Base (Unix)	Common components for all Unix(-like) systems
DB2SPI Windows	DB2SPI Base	Base management components for DB2 servers (Unix and Windows)

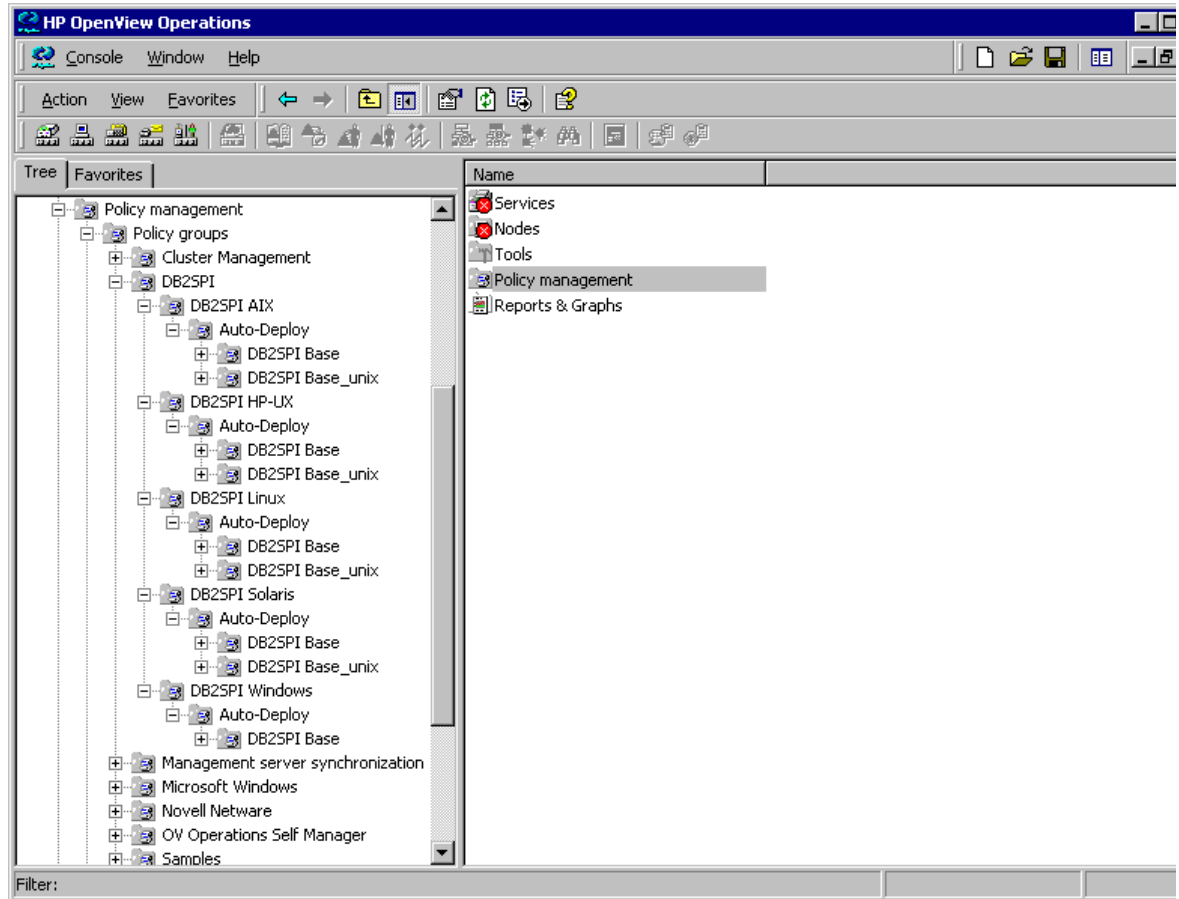
The platform-specific DB2SPI template groups (policy groups in OVO/Windows) are automatically assigned to the platform-specific DB2SPI node groups when installing the DB2SPI. Individual nodes need to be assigned to those node groups, or the platform-specific DB2SPI template groups must be assigned specifically to such individual nodes that are not contained in a DB2SPI node group.

Note that the management server itself does not need to be a DB2SPI managed node, but it must receive all scripts (actions and commands) for the DB2SPI.

#### Policy Groups in OVO/Windows

Figure 13: DB2SPI policy groups shows the policy groups that are available after the successful installation of the DB2SPI software.

Figure 14: DB2SPI policy groups



## Other OVO Administrator Tasks

### Suppressing Unwanted Messages from "su" Monitoring

The DB2SPI sometimes has to switch the user environment in order to be able to execute particular applications properly. Since the root-user on the DB2 server is involved in this action, entries are generated in the `syslog` log file, indicating that an "su" event has taken place.

The standard `Logfile:syslog` template on HP-UX managed nodes or the `Logfile:su` template on AIX managed nodes detect these `su` events and notify the user by sending a message (with an "unknown" or "normal" severity, respectively) to the message browser.

You can prevent these messages appearing in the message browser by adding a condition to the `Logfile:syslog` template on HP or the `Logfile:su` template on AIX. The new condition would suppress these (regular) messages, similar to the condition that OVO uses on the management server itself to drop "su" events in the ORACLE environment.

For more information about suppressing messages generated by the DB2SPI, see "Troubleshooting" on page 108.

## DB2SPI Administrator Tasks

This section describes the high-level, day-to-day tasks the DB2SPI Administrator is expected to perform. This section covers the following areas each of which is described in more detail in the sections that follow:

- General Remarks in Advance
- DB2SPI License Tools
- Maintaining DB2 Instances, Databases and the Service Tree
- Affecting the Performance Data Flow
- Other Tasks and Tools

To assist the DB2SPI user in the performance of every-day tasks, the installation process of the DB2SPI creates two application (tool) groups specifically for the DB2SPI:

DB2	contains applications for operating the DB2 database
DB2SPI Admin	contains applications for the administration of the DB2SPI

### General Remarks in Advance

#### GUI Prerequisites and common Steps

In OVO/Windows environments, all applications can be run from any OVO/Windows Console.

The OVO/Windows Console on the management server can be used without any other steps to take. On any other console station, a communication component (ATOP) has to be installed, before the DB2SPI tools can be executed from these Consoles.

When you run any of the DB2SPI applications, the DB2SPI first determines whether or not multiple instances of the DB2 database are present on the DB2 server where you want the application to run. If only one DB2 instance is present, the application immediately carries out the task requested. If there is more than one DB2 instance present on the managed node you selected, the DB2SPI first prompts you to select a DB2 instance from the list of configured instances.

#### DB2SPI Admin Tools

The application group DB2SPI Admin contains applications that enable the DB2SPI administrator to manage the DB2 instances and general DB2SPI behavior with OVO.

The list shown next represents the DB2SPI Admin application group, which by default contains the following applications (tools in OVO/Windows):

- Change AdmUser
- Config Delete
- Config Setup
- Database Filter
- DB2SPI Disable
- DB2SPI Enable
- Edit UDM Config
- License Add
- License Check
- License List

- MWA Disable
- MWA Enable
- OPCMON Disable
- OPCMON Enable
- Prepare UDM Config
- Self-Healing Info DB2 Server
- Self Healing Info OVO Server
- ServiceTree Update
- Snapshot Disable
- Snapshot Enable
- Trace Disable
- Trace Enable

These applications appear in the DB2SPI Admin Tools application-group window as shown in "DB2SPI Admin Tools "on page 44.

## DB2SPI License Tools

Before any DB2 monitoring can be performed, you need to have DB2SPI runtime licenses installed. There are three tools available for the licensing context:

License Add:

Add DB2SPI runtime licenses on the management server

License List:

Show all runtime licenses currently installed on the management server

License Check:

Verify that the managed node where executed has a valid runtime license

### Adding DB2SPI Licenses

All DB2 servers monitored with the DB2SPI need to have an appropriate runtime license. Since A.02.00 / B.02.00 this is a node-locked license which is checked by the DB2SPI whenever access to DB2 is requested via the DB2SPI.

There is only one license file per customer, holding all runtime licenses that have been obtained. This file is distributed to the managed nodes together with the "instrumentation" with standard OVO means.

In order to add new runtime licenses to this common file, a tool is available in the DB2SPI Admin group, "Add Licenses".

In order to install new runtime licenses, the following steps must be performed:

#### Start the License Add Tool from the GUI

- 1 Make sure you have placed the DB2SPI License Update File in a common folder (directory) on the management server.
- 2 On OVO/Windows C : \TEMP.
- 3 In the OVO GUI, execute the "Add Licenses" application from the "DB2SPI Tools" application group with the "Start Customized" option.



- 4 In the window popping up, you need to specify the name of the recently installed DB2SPI License Update File with full path information.
- 5 Then press "OK" to start the process.

An application output window will appear showing the progress of the license installation.

### License Terms

It is mandatory to accept the license terms of the DB2SPI in order to install runtime licenses. Therefore we provide these terms in conjunction with the license installation and they can be viewed if desired.

When the question appears:

**Do you want to read the license terms for the DB2SPI [yn]?**

answer "y" or "n".

If you selected to read the license terms, they will be shown in this window in a paged manner, with the option to abort reading at any time. The text is identical with the license terms signed with the purchase of the product.

### License Acceptance

After the terms have been shown in their entirety (or this step has been skipped with a "n" given earlier, or aborted during the read process, the question appears:

**Do you accept the license terms for the DB2SPI [yn]?**

If you say "n" (no), installation of the license(s) is terminated and the product will not be licensed and cannot be used with DB2 server.

If you say "y" (yes) you indicate the acceptance of the terms and license installation will continue.

Al full (though abbreviated) transcript of the installation looks like:

**In order to install licenses you have to accept  
the license terms for the DB2SPI.**

**Do you want to read the license terms for the DB2SPI [yn]? y**

```
*****
*   DB2SPI License Terms                               *
*****
```

**This software end user license agreement is a legal agreement between you and NiCE GmbH. It provides a license to use the software and contains warranty information and liability disclaimers.**

**By installing the software and using the software, you are confirming your acceptance of the software and agreeing to become bound by the terms of this agreement. If you do not agree to be bound by these terms, then uninstall the software from your computer.**

#### 1. Ownership

**1.1. The license gives you limited license to use the Software.**

**NiCE GmbH and its suppliers retain all right, title and interest,**

including all copyright and intellectual property rights, in and to, the Software and all copies thereof. All rights not specifically granted in this license agreement, including Federal and International Copyrights, are reserved by NiCE GmbH and its suppliers.

```
Press RETURN or Q to quit ...q
Do you accept the license terms for the DB2SPI [yn]? y
Done with ibm/rs6000/aix/monitor
Done with sun/sparc/solaris/monitor
Done with hp/s700/hp-ux10/monitor
Done with hp/s700/hp-ux11/monitor
Done with hp/s800/hp-ux10/monitor
Done with hp/s800/hp-ux11/monitor
Done with hp/pa-risc/hp-ux11/monitor
Done with linux/intel/linux24/monitor
Done with linux/intel/linux22/monitor
Done with ms/intel/nt/monitor
Done with hp/pa-risc/hpux1100/monitor
Done with hp/ia64/hp-ux11_32/monitor
Done with hp/ipf32/hpux1122/monitor
Done with sun/sparc/solaris7/monitor
Done with ms/x86/winnt/monitor
Done with linux/x86/linux24/monitor
```

Finished update of DB2SPI licenses. You need to deploy them to the managed nodes now.

Press any key to close the window ...

### List all installed DB2SPI Runtime Licenses

To verify the list of runtime licenses installed on the given OVO management server the tool "License List" can be executed. When being executed it lists all runtime licenses with the related nodes and expiry dates in an ATOP window.

An example is given here:

```
DB2SPI License Report on OVO server starwars.nicelab.de:
=====
```



This report lists all licenses found in the license file on the management server. No validation checks are performed for this report.

Version	Expiry Date	Locked to
== A.02.08	2005-12-31	barrayar
== A.03.00	2005-07-31	starwars
<= A.02.05	2999-12-31	* (not locked)
<= A.02.00	2999-12-31	* (not locked)

The keys preceding the version mean: "identical" ("==") or "up to" ("<=")

An expiry date of 2999-12-31 means an unlimited time frame.

### License Check

Executing the License Check tool can help finding out if there is a valid runtime license for this node. It is advisable to execute it if the DB2SPI cannot be configured at all with messages like "no license found", or if similar messages show up during normal operation.

As you know, the runtime licenses are node locked and / or time-restricted, so installed runtime licenses may become invalid when the "hostname" changes or the evaluation time frame expires.



The typical output of the License Check is shown here:

---

#### DB2SPI License Report on managed node barrayar.nicelab.de:

=====  
 This report lists all licenses found in the license file on the managed node. Only licenses which were generated for this node are listed.

Version	Expiry Date	Locked to	License is
== A.02.08	2004-12-31	barrayar	Valid
<= A.02.05	3000-12-31	* (not locked)	Invalid
<= A.02.00	3000-12-31	* (not locked)	Invalid

---

## Maintaining DB2 Instances, Databases and the Service Tree

This section contains information that you require when using the DB2SPI to maintain the DB2 instances you are managing with OVO.

### Configuring DB2 Instances (Unix and Windows)

A number of different instances of the DB2 database can run on a DB2 server at any one time. All or any combination of these instances might need to be managed and





maintained by OVO. In order to define which instances OVO should manage, you need to run the application "Config Setup" on the DB2 server. For more information about configuring instances of DB2, see "Configuring DB2 Instances" on page 31.

► Note: If the DB2 "Config Setup" is not executed correctly, errors or warning are displayed and you might be unable to execute any other DB2SPI applications on the DB2 servers.

In addition, the DB2SPI will not be able to monitor the different DB2-related log files and processes on the DB2 server or even collect performance data.

Also, strange message may appear in the log files and / or message browser.

To track any issue during this important phase, we collect lots of information in the log file and a separate trace file.

The Config Setup application prompts you for the names of the different instance users when executed on Unix DB2 server. You should have the names available when running this program. These names need to be provided by the DB2 administrator for the respective DB2 server system.

The DB2SPI can manage any number of instances on a DB2 server. Multiple databases can be defined within an individual DB2 instance. By default, the DB2SPI manages all databases within the instances automatically.

Individual databases can be excluded from monitoring during the instance setup already, but also at a later time using the "Database Filter" application.

Also note that the DB2 service tree display in the Service Navigator only shows instances that are configured to be managed with this "Config Setup" application.

Changing the list of managed instances in a DB2 environment that has already been managed with the DB2SPI can be achieved by the following sequence:

- Clear previous configuration by executing "Config Delete"
- Re-run "Config Setup"
- Run "DB2SPI Enable"

!! Please be aware that this sequence drops all configuration information, metric data already collected and filter settings.

### Database Filter

This function can be used to disable databases selectively from being monitored.

After selecting the instance where to exclude databases from, the application window shows all available databases and each one has to be confirmed or denied, as can be seen in the following log:



Hostname: dengue

```
Exclude Databases from being monitored
=====
```

```
Database "IN4_DB1" is monitored. Do you want to exclude it? [yn] >n
Keep exclusion of "IN4_DB2" from monitoring? [yn] >y
```

Database Filter application for db2inst4 has completed

Whenever changing the database filters, the DB2 service tree will be updated automatically within short timeframe.

Changing the Administrative Account (DB2 on Windows Nodes)

In Windows environments, we gain access to the managed instances and databases via the DB2 administrative account. This account might be changed by the DB2 administrators at any time to follow some security policies and the DB2SPI needs to be re-configured to adapt to changed account information.

Since we store this account information well encrypted, we need a separate tool to modify these account data.

The following shows a typical dialogue for the change of account information this way:



---

Hostname: W155

Change DB2 Administrator user name and password

=====

You need both the admin user account and the password.

Do you want to continue changing [yn]? y

Please enter the name of the DB2 admin user (e.g. db2admin): db2adm

Please enter the password of this user (displayed in plain text):  
db2adm

Press any key to close the window ...

Configuration Deletion

If you want to delete the DB2SPI from a DB2 server, or if you entered data incorrectly during the instance setup, you can execute the Config Delete application to remove all instance configuration settings. You can re-enter the new or corrected values by running "Config Setup" again.

When clearing the instance settings this way, the OVO message source templates (policies) are still deployed, but disabled automatically.

If you want to disable DB2 monitoring permanently, you should also remove the node from the respective DB2SPI node group or de-assign the template groups from it, if it is an individual node. In both cases, make sure to "Install & Update Software & Configuration" after that.



When dropping the instance definition, the DB2 service tree will be updated automatically and delete the respective branches for this node.

A typical dialogue is listed in the following log:

```
dengue
      DB2SPI Configuration Deletion
      =====

Removing DB2SPI configuration files ...

(CAUTION: this might include a restart of MWA)
Are you sure [yn]?y
Please wait ...
This operation may take some time, because we must
synchronize this action with the OVO agent
processing DB2_admlog_unix ...

processing DB2_diag_unix ...

processing "DB2_syslog(HP-UX)" ...

processing DB2_opcmsg ...

processing DB2_metric_30m_unix ...

processing DB2_metric_10m_unix ...

processing DB2_procmon_unix ...

processing DB2_mwalogger ...

processing DB2SPI_discover_svctree_unix ...

processing DB2SPI_fs_adm_unix ...

processing DB2SPI_fs_db2spilog_unix ...

processing DB2SPI_fs_db2spitrc_unix ...

processing DB2SPI_fs_diag_unix ...
```

processing DB2SPI\_ownlog1\_unix ...

processing DB2SPI\_svctree\_unix\_auto ...

processing DB2SPI\_svctree\_unix\_upd ...

Removing

Removing

Removing

Removing

Removing performance measurement ...

Shutting down the MeasureWare server daemons..

Shutting down the alarmgen process. This may take awhile depending upon how many monitoring systems have to be notified that MeasureWare Server is shutting down.

The alarmgen process has terminated

Shutting down the perflbd process

The perflbd process has terminated

The agdbserver process terminated

The rep\_server processes have terminated

The MeasureWare Server has been shut down successfully

The MeasureWare server daemons are being started.

The MeasureWare Location Broker daemon

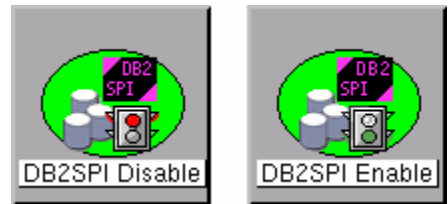
/opt/perf/bin/perflbd has been started.

The application: "db2s\_setupinst.pl -erase" has terminated.

Please press RETURN to close the window.

## Enable and Disable the entire DB2SPI

There is an application pair, which is used to switch operation of the DB2SPI on the given node, "DB2SPI Enable" and "DB2SPI Disable". These tools affect the operation of the policies belonging to the DB2SPI and hence enable / disable all background monitoring activity of the SPI. All DB2SPI tools are kept unaffected and so are automatic and operator actions.



Note, that the disabling may take a while to complete as we have to wait for proper synchronization points in the operation of the OVO agents processing the policies.

Enabling / disabling attempts to determine all policies the have "DB2\_" or "DB2SPI\_" as part of their names and switches them accordingly (except "DB2\_nnnn" type, which are passive threshold monitor policies).

When using different policy names the user has to make sure that these fragments are still part of the policy names in order to preserve functioning of these tools. Note that these are also applied during "Config Setup" and "Config Delete".

## Updating the Service Tree

The DB2 services available in the service tree are determined from the list of instances and their database exclusion lists, and the discovery process also takes into account the DB2 configuration itself. An update of the service tree is triggered internally whenever a "Config Setup" or " Database Filter" is executed, and the DB2SPI periodically checks the DB2 instances if new databases should have been created or others have been deleted or filtered.



However, the periodic check might be inappropriate sometimes, and the user might want to enforce an update immediately. This can be achieved by using the "ServiceTree Update" application. When applied to a managed DB2 server node, it immediately performs the discovery and cross-checks with the instance and database exclusion lists.

More details about the service tree data processing can be found in section "Service Management with OVO" on page 103.

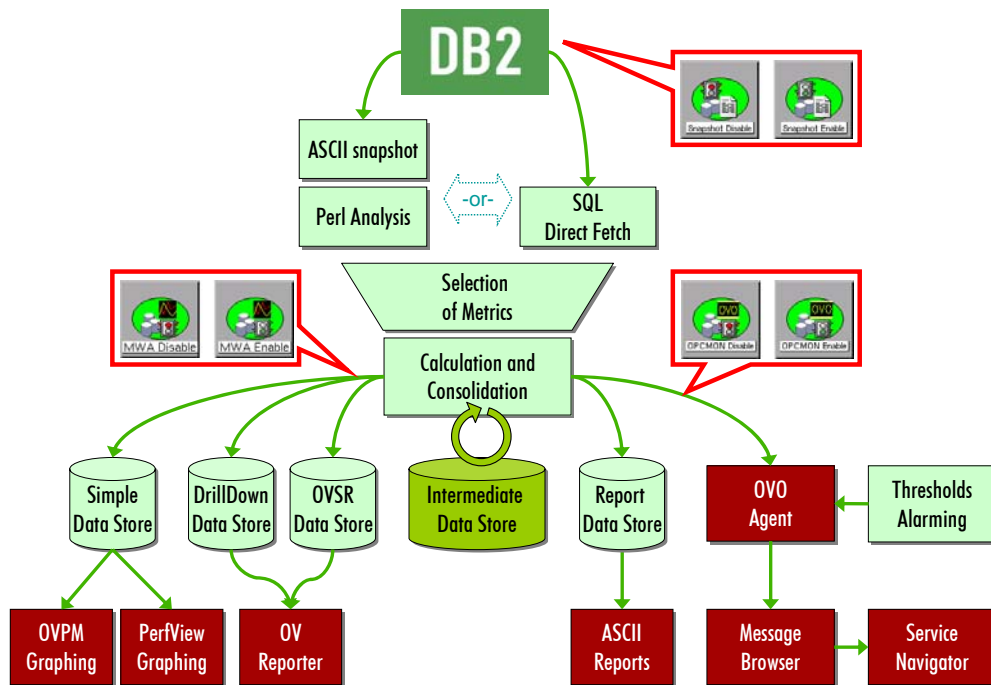
## Affecting the Performance Data Flow

This section contains information that you require when maintaining the processing of metric data collected. Please see "Performance Data Collection (Standard Metrics)" on page 96 for details how performance data are collected and processed by the DB2SPI.

The data flow shown in Figure 15: : Metric Data Collection and affecting Tools on page 62 can be affected at three points, symbolized there by three pairs of application labels and implemented as applications in the "DB2SPI Admin" application group.

In this section we describe the purpose and steps of these applications.

Figure 16: : Metric Data Collection and affecting Tools



### Performance Data Access Methods

There are two ways to process performance data, either via Perl analysis of ASCII snapshot files created by DB2 or via direct SQL access.

Perl analysis is possible for all versions of DB2, for standard metrics as well as for user defined metrics (UDM). However, this is a rather "expensive" approach, especially if many applications or tablespaces need to be monitored.

SQL direct fetch is a very fast access method without the need to create and interpret snapshot value files. This is available for DB2 8.1 and later only. Even if SQL direct fetch is enabled, UDMs are still processed via snapshot files and Perl analysis.

The method can be switched at any time by editing the global configuration file `db2s_spi.cfg` on the managed as described there.

**Warning:**  
Changing the access method to ESQ for older versions of DB2 than 8.1.0 is not supported and can lead to lots of errors logged to the DB2SPI log file and the OVO message browser.

Please note that for both methods the DB2 internal performance monitors must be enabled (see next section, Enable / Disable DB2 Snapshots) in order to collect and retrieve these data.

### Enable / Disable DB2 Snapshots

DB2 must be configured to provide performance snapshot data. By default, there are no such data provided, so there would be no performance data for threshold monitoring, graphing and reporting.

With the application `Snapshot Enable` the DB2 database is reconfigured and restarted to provide such information. Note, that this requires a short shutdown of the database, which may be a critical step in some production systems.

The reason for doing so is that we modify the "default switches" for the DB2 internal monitors, and they need to cycle the database to take effect.

In

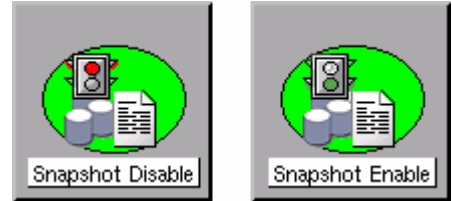


Figure 17: Dialogue during "Snapshot Enable" process

```
-----
Starting snapshot creation on dengue
=====

Please select an instance on dengue
(to abort press 0)
1.      db2inst1
2.      db2inst4
3.      db2inst7

>1
This command will stop and restart the database. Are you sure
[yn]?y

Please wait. This takes some time ...

DB20000I  The DB2STOP command completed successfully.
DB20000I  The UPDATE DATABASE MANAGER CONFIGURATION command
completed successfully.
DB20000I  The DB2START command completed successfully.

The application: "db2s_snapshot_on.pl" has terminated.
Please press RETURN to close the window.
```

you see the dialogue of `Snapshot Enable` execution:

**Figure 17: Dialogue during "Snapshot Enable" process**

```
Starting snapshot creation on dengue
=====

Please select an instance on dengue
(to abort press 0)

1.      db2inst1
2.      db2inst4
3.      db2inst7

>1

This command will stop and restart the database. Are you sure
[yn]?y

Please wait. This takes some time ...

DB20000I  The DB2STOP command completed successfully.
DB20000I  The UPDATE DATABASE MANAGER CONFIGURATION command
completed successfully.
DB20000I  The DB2START command completed successfully.

The application: "db2s_snapshot_on.pl" has terminated.
Please press RETURN to close the window.
```

Disabling DB2 snapshot creation works similar by executing the Snapshot Disable application in the DB2SPI Admin application group,

A proper message is written to the DB2SPI log file and to the OVO message browser to inform about the change of the switch.

Alternatively, enter the following command in a command shell on the DB2 server:

```
db2 update dbm cfg using DFT_MON_BUFPOOL on DFT_MON_LOCK on
DFT_MON_SORT on DFT_MON_STMT on DFT_MON_TABLE on DFT_MON_UOW on
```

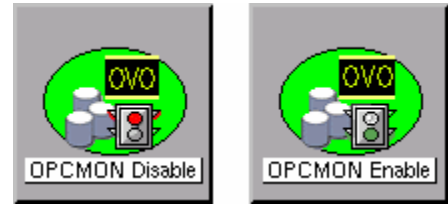
Note that DB2 may sometimes show misleading messages on the terminal window when performing this switch, consequently making the DB2SPI believe that it failed.

However, we found that sometimes these are just warnings that have no impact. You should verify correct operation afterwards with the "Show Snapshot" tool if you are in doubt.



## Enable / Disable OPCMON Forwarding

The forwarding of metric data to OVO and hence threshold monitoring and OVO message creation can be enabled or disabled with the OPCMON Enable and OPCMON Disable applications.



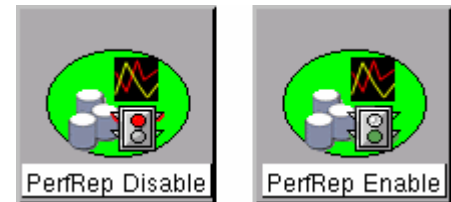
► Note that, when disabled, threshold monitoring does not take place and you will not receive any messages in the OVO message browser if DB2 resources are outside their normal range.

At the same time, metrics may be forwarded to OVPA/CODA for reporting / graphing.

A proper message is written to the DB2SPI log file and to the OVO message browser to inform about the change of the switch.

## Enable / Disable Metric Forwarding to OVPA/CODA

DB2 systems that do not have OVPA/CODA installed should disable "performance data forwarding". A pair of switches is available to achieve this change in DB2SPI internal processing, named MWA Enable and MWA Disable.



A proper message is written to the DB2SPI log file and to the OVO message browser to inform about the change of the switch.

At the same time, metrics may be forwarded to OVO for threshold monitoring and alerting.

Note, that this applies to both OVPA and CODA data storage types, whatever is apparent on the managed node.

## Other Tasks and Tools

### Metric Thresholds with Template Name Spaces

By default, the DB2SPI uses fix names for the metric threshold monitor templates in OVO/Unix and OVO/Windows. These names are hard coded in the `db2s_metrics.cfg` configuration and hence apply to all managed systems in a similar way.

The name space extension allows prefixing the names of these templates with a string freely definable, thus making it possible to maintain different sets of threshold monitors while still using the same `db2s_metrics.cfg`.

### Call Syntax

Whenever calling `db2s_db2mon.pl`, you may pass a `-t <prefix>` parameter before the list of metrics in the command line like:

```
db2s_db2mon.pl -t MYDEV_ -i <metric_list>
```

This will forward all values determined for the metrics listed to respective threshold monitors which are named `MYDEV_<original_name>`.

### Usage in the DB2SPI

This can be used in the DB2SPI easily by copying the schedule templates `DB2_10m_metrics_*` and `DB2_30m_metrics_*` to new names and adapting the `db2s_db2mon.pl` call in them accordingly.

- ⚠ Make sure that you will deploy only one set of metric schedule templates to the nodes, according to their "threshold set" desired.

Note that all instances and databases on a given system will use the same templates, there is no instance or database specific distinction possible.

### Tracing Enable / Disable

The DBSPI Admin application group contains two functions to enable and disable tracing the DB2SPI itself. Tracing can be helpful in troubleshooting difficulties in the operation of the DB2SPI. These applications act as simple switches to enable / disable tracing from an overall perspective. See "Tracing" on page 123 about details how to configure specific processes and sections of the DB2SPI to be monitored.

- ⚠ Enabling tracing without explicit specification of a process or process group to be checked is not recommended, as this produces a huge amount of data.

### Providing Information for the HP Self-Healing Collector

If a problem is detected and real-time data needs to be collected to determine the cause. The DB2SPI provides an interface to the HP Self-Healing Service, which helps solving product problems by automated forwarding to the respective HP support channels. To collect the required data the DB2SPI data collector is run in one of the following two ways:



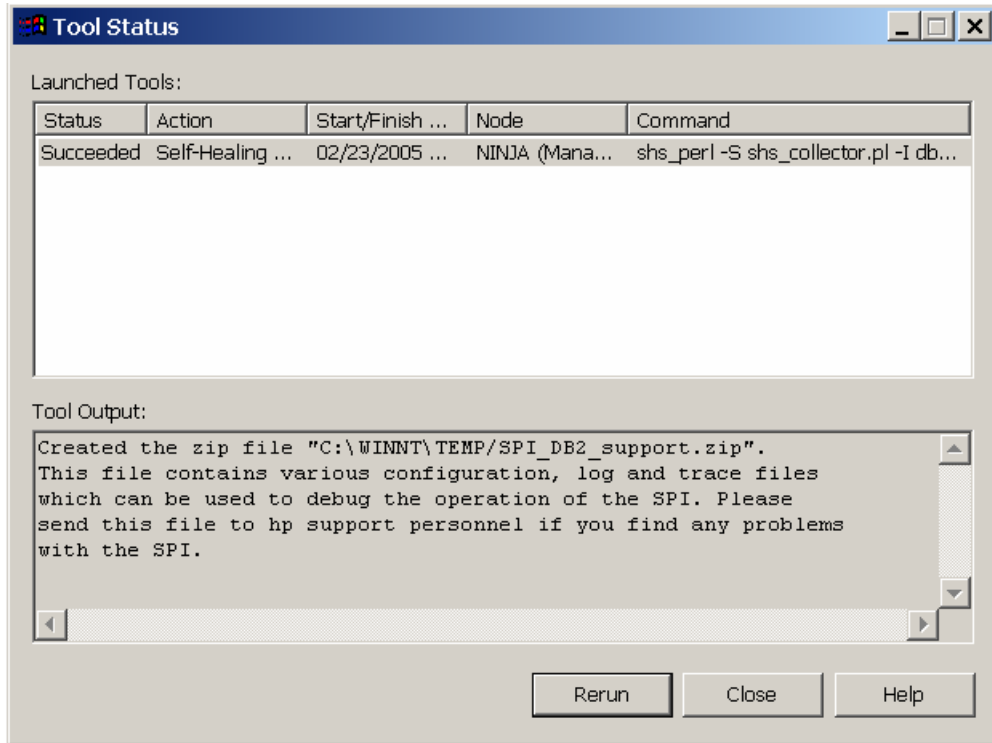
#### **From the Self-Healing GUI**

If the Self-Healing Service client is installed on the managed node, the customer manually enters the fault information in the manual submission screen of the Self-Healing Services web user interface. Please refer to the document *HP OpenView Self-Healing Services Integration Overview* document for details.

#### **As an OVO Application**

If the Self-Healing Service client is not supported (or is not installed) on a managed node, it is run by launching the new DB2SPI tool "Self-Healing Info" on the managed node. A sample tool execution window looks as follows:

**Figure 18: OVO/Windows Self-Healing Tool Output**



The complete path to the directory, where the collected data was stored is given in the tool output window (see example above). The data is contained in a .zip or .tar file, depending on the operating system on the managed node (Windows/Unix).

The uncompressed data / files can also be found in the subdirectory SPI\_DB2 .

## DB2 Operator Tasks

This section describes the tasks that the DB2 operator can expect to perform on a regular basis. The section covers the following topics:

- Using DB2SPI Messages
- Tool Execution – some general Remarks
- DB2 Information Tools
- Simple Access to DB2
- Advanced Management Tools
- Graphical Data Presentation Utilities

### Using DB2SPI Messages

DB2SPI users use the `Message Browser` window to view and manage DB2SPI-related messages. Messages sent by the DB2SPI are assigned to one of two DB2SPI message groups:

**DB2:** for database-related messages.

Users who have been assigned either the DB2 Operator or the DB2SPI Admin user profile can see messages in the DB2 message group.

**DB2SPI:** for SPI related messages.

Messages in the DB2SPI message group can only be seen by users who have been assigned the DB2SPI Admin user profile.

Acting upon these messages is the standard task for OVO operators. DB2SPI attempts to support this DB2 administration task by providing explanatory instruction texts and metric drill down annotations, created automatically by the event interceptor.

### Instructions for DB2 and DB2SPI Events

Most events shown up in the message browser provide some additional information how to interpret the event and how to deal with it. Some of these instruction texts are defined with the template, but most of them are provided in a separate instruction text data file.

Please note that retrieval of such texts may take some time on slower systems.

Pressing the "Instructions" button in the operator GUI shows up specific instructions for the respective event, where available.

An example from "Sort Heap Monitoring" might look as follows:

```
The number of sorts that have requested heaps after the sort heap
threshold has been reached.
```

```
Under normal conditions, the database manager will allocate sort heap
using the value specified by the sortheap configuration parameter.
```

```
If the amount of memory allocated to sort heaps exceeds the sort heap
threshold (sheapthres configuration parameter), the database manager
will allocate sort heap using a value less than that specified by the
sortheap configuration parameter.
```

```
Each active sort on the system allocates memory, which may result in
sorting taking up too much of the system memory available.
```

```
Sorts that start after the sort heap threshold has been reached may
not receive an optimum amount of memory to execute, but, as a result,
the entire system may benefit. By modifying the sort heap threshold
and sort heap size configuration parameters, the performance of sort
operations and/or the overall system can be improved.
```

```
If this element's value is high, you can:
```

- (1) Increase the sort heap threshold (sheapthres) or,
  - (2) Adjust applications to use fewer or smaller sorts via SQL query changes.
- 

### Automatic Actions for Metric Events

Many metric events have automatic actions assigned that collect additional information about the cause. To provide this drill-down capability, the ASCII reports tool is executed automatically with the appropriate parameters.

The execution and success of such an action can be seen in the "A" column of the message browser.

The result of the additional data collection is available as an annotation.

Please note that the node must be "controlled" in the OVO/Unix node bank to allow execution of the automatic action. "Monitored only" nodes are not able to start any action.

An example for the ASCII report is given with the description of the tool in "ASCII Report" on page 70.

## Tool Execution – some general Remarks

### Prerequisite: ATOP

In OVO/Unix all applications (tools) can be run from the OVO operator Motif GUI or from the OVO operator Java GUI. The same is true in similar sense for OVO/Windows.

Some applications (tools) perform bidirectional I/O (input/output). These are executable only via the generic communication layer, ATOP.

The Motif GUI ATOP interface to the DB2SPI applications is available without any other steps to take. For the Java GUI interface and the OVO/Windows management stations it must be enabled on the Java GUI station (management station) of the operator similar to the OVO Java GUI itself.

### Common Steps for DB2 Operator Applications

When you run any of the DB2 Operator tools in the DB2 application group, the DB2SPI first determines whether or not multiple instances of the DB2 database are present on the DB2 server where you want the application to run. If only one DB2 instance is present, the application immediately carries out the task requested. If there is more than one DB2 instance present on the managed node you selected, the DB2SPI first prompts you to select a DB2 instance from the list of configured instances.

Enter the number next to the DB2 instance you want to interrogate, for example; **1** for the first DB2 instance listed. Alternatively, enter **0** if you want to exit at this point.

In any case, press <**RETURN**> after your entry.

### The DB2SPI Operator Applications

Before executing any of the DB2SPI operator applications make sure to understand the prerequisites and common steps.

The DB2SPI provides the following applications for the DB2 operator:

- ASCII Report
- DB2 Command Line Processor
- Instance List
- Instance Start
- Instance Stop
- Predef.OVPM
- Replication Status
- Show Manager Config
- Show DB Config
- Show Snapshot
- DB2 Management Tools:

- Application Management
- Backup / Restore
- Data Management
- Database Management
- Database Migration
- Instance Management
- Miscellaneous
- Node Management
- Table Management
- Tablespace Management

► Most of the DB2SPI-operator applications will only work correctly if the DB2SPI administrator (or an OVO user with the DB2SPI administrator user profile) has already defined the DB2 instances, which the DB2SPI is to manage. For more information about setting up DB2 instances in the DB2SPI, see on page 31.

## DB2 Information Tools

### ASCII Report

This tool allows the creation of detailed reports for a number of functional DB2 areas. We perform a drill-down analysis from the instance level down as far as possible for each area (database, tablespace, application) and process these data in tabular form.

- 1 When started, it first shows a list of report areas where the user may choose from. The user may enter the number of the area he/she is interested in and press <RETURN> to get it executed.
- 2 Next, the individual reports from that area are shown to allow selection. The user may enter the number of the report he/she wants to get in and press <RETURN> to get it executed.
- 3 Finally, the user has to select the instance and database for which the report shall be created.



The DB2SPI will request the respective data from the latest performance metric snapshot that has been created and displays them in the application window.

At the end, the script asks if the output of the report shall be saved to disk. If confirmed, a text file with the respective output is saved to disk and can be viewed at any time.

A typical dialogue and output looks as follows:

```

Please select a report area
(to abort press 0)
      1.      Locks and deadlocks
  
```

2. Connections
3. Agents and applications
4. Statement activity
5. Disk I/O
6. Buffer pool
7. Transaction logs
8. Miscellaneous
9. Fast Communications Manager
10. Sorts

>5

Please select a report

(to abort press 0)

1. Average direct read times for applications
2. Average direct write times for applications
3. Average sectors read per direct read
4. Average sectors written per direct write

>3

Please select an instance on dengue

(to abort press 0)

1. db2inst1
2. db2inst4
3. db2inst7

>2

Please select a database for db2inst4

(to abort press 0)

1. IN4\_DB1
2. IN4\_DB2

>2

\*\*\*\*\*  
\*\*\*\*\*

Instance: db2inst4

Database: IN4\_DB2

\*\*\*\*\*  
\*\*\*\*\*

Report 0362 (Average sectors read per direct read)

Date: 20031012.154635

\*\*\*\*\*  
\*\*\*\*\*

AUTH_ID	CLIENTLOGIN_ID	APPL_NAME	APPL_ID	APPL_HDL	DIR_RD_REQ	DIR_RD	AVG_DIR_RD
DB2INST1	db2inst1	db2bp	*LOCAL.db2inst1.059412132726		195	1	2
DB2INST1	db2inst1	db2bp	*LOCAL.db2inst1.05BEC2133008		200	1	2
DB2INST4	db2inst4	db2bp	*LOCAL.db2inst4.063D22133554		84	1	2
DB2INST1	db2inst1	db2bp	*LOCAL.db2inst1.05FCF2133304		205	1	2
DB2INST4	db2inst4	db2bp	*LOCAL.db2inst4.0666B2133839		89	1	2

AUTH\_ID: The Authorisation ID for the application  
 CLIENTLOGIN\_ID: The Login ID for the client application  
 APPL\_NAME: The name of the application  
 APPL\_ID: The ID of the application  
 APPL\_HDL: The application handle of the application  
 DIR\_RD\_REQ: Direct read requests by the application  
 DIR\_RD: Direct reads by the application  
 AVG\_DIR\_RD: Average direct reads per request

The application: "db2s\_asciirep.pl" has terminated.



Please press RETURN to close the window.

## Instance List

The Instance List application opens a terminal window that lists all instances of the DB2 database that are configured on the selected managed node. Note that list of DB2 instances displayed by the db2ilist application does not necessarily reflect the list of DB2 instances managed by the DB2SPI. This is because the DB2SPI Administrator might have decided to omit some DB2 instances during the Config Setup application. Press <RETURN> to close the window.



Managed and unmanaged instances can be distinguished by the prefix:

- Managed instances are listed with a preceding "+"
- Unmanaged instances are listed with a preceding "-"

For each instance, all databases are listed, too, properly indented under each instance to allow easy reading. Managed and excluded databases can be distinguished by the prefix:

- Managed databases are listed with a preceding "+"
- Excluded databases are listed with a preceding "-"

The following example shows a typical output:

```
Looking for instances on dengue...
=====
```

Please wait. This may take some time ...

```
+ db2inst1
  + IN1_DB1
  + IN1_DB2
  + SAMPLE
+ db2inst4
  + IN4_DB1
  + IN4_DB2
+ db2inst7
  + IN7_DB1
  + IN7_DB2
- db2inst2
- db2inst3
- db2inst5
- db2inst6
- db2inst8
- db2inst9
```

- db2ins10

Search finished.

The application: "db2s\_ilst.pl" has terminated.

Please press RETURN to close the window.

---

### Replication Status

The Replication Status tool displays the current status of the DB2 replication, if enabled. Please note that we only provide information about DB2 Capture and Apply processes which run on the instances specified during setup.

The typical output of a Replication Status execution looks as follows:



#### DB2 Replication Monitoring - Status Information

```
-----  
-----  
  
Settings (DB2SPI Config):  
DB2SPI_REPLICATION          1  
  
-----  
  
Sun Microsystems Inc.   SunOS 5.10       Generic January 2005  
2005-11-21-10.00.14.105152 ASN0520I "AsnAcmd" : "DEPTQUAL" :  
"Initial" : The STATUS command response: "HoldLThread" thread is in  
the "is waiting" state.  
2005-11-21-10.00.14.105886 ASN0520I "AsnAcmd" : "DEPTQUAL" :  
"Initial" : The STATUS command response: "AdminThread" thread is in  
the "is resting" state.  
2005-11-21-10.00.14.106088 ASN0520I "AsnAcmd" : "DEPTQUAL" :  
"Initial" : The STATUS command response: "WorkerThread" thread is in  
the "is resting" state.  
  
Sun Microsystems Inc.   SunOS 5.10       Generic January 2005  
2005-11-21-10.00.17.265212 ASN0520I "AsnCcmd" : "ASN" : "Initial" :  
The STATUS command response: "HoldLThread" thread is in the "is  
waiting" state.  
2005-11-21-10.00.17.265958 ASN0520I "AsnCcmd" : "ASN" : "Initial" :  
The STATUS command response: "AdminThread" thread is in the "is  
resting" state.  
2005-11-21-10.00.17.266155 ASN0520I "AsnCcmd" : "ASN" : "Initial" :  
The STATUS command response: "PruneThread" thread is in the "is  
resting" state.
```

2005-11-21-10.00.17.266316 ASN0520I "AsnCcmd" : "ASN" : "Initial" :  
The STATUS command response: "WorkerThread" thread is in the "is  
resting" state.

The application: "db2s\_ilst.pl" has terminated.

Please press RETURN to close the window.

### Show Database Configuration

The Show DB Config application opens a terminal window and displays the manager configuration for the DB2 instance that is being selected.

Screen output is separated into pages. After each page the user may decide to continue viewing the output or jumping to the end.

In order to continue browsing through the snapshot, simply press <RETURN>.

If you want to cancel, hit <Q> and <RETURN>.



### Show Manager Configuration

The Show Mgr Config application opens a terminal window and displays the manager configuration for the DB2 instance that is being selected.

Screen output is separated into pages. After each page the user may decide to continue viewing the output or jumping to the end.

In order to continue browsing through the snapshot, simply press <RETURN>.

If you want to cancel, hit <Q> and <RETURN>.



This is a sample session showing the ATOP window with the "Show Manager Configuration" output:

Figure 19: Show Manager Configuration session output

```
ATOP Window - Press ^C to terminate the application
Please select an instance on BLUEBOX2
(to abort press 0)
  1.      DB2MPP
  2.      DB2INST4
>1

      Database Manager Configuration

      Node type = Partitioned Database Server with local and remote clients

Database manager configuration release level          = 0x0900

Maximum total of files open              (MAXTOTFILOP) = 16000
CPU speed (millisec/instruction)         (CPUSPEED)   = 3.936202e-007
Communications bandwidth (MB/sec)        (COMM_BANDWIDTH) = 1.0000000e+000

Max number of concurrently active databases  (NUMDB) = 3
Data Links support                          (DATALINKS) = NO
Federated Database System Support          (FEDERATED) = NO
Transaction processor monitor name         (TP_MON_NAME) =

Default charge-back account                (DFT_ACCOUNT_STR) =

Java Development Kit 1.1 installation path (JDK11_PATH) =

Diagnostic error capture level              (DIAGLEVEL) = 3
Hit RETURN to continue or Q to save/quit ...
Notify Level                               (NOTIFYLEVEL) = 2
Diagnostic data directory path             (DIAGPATH) =

Default database monitor switches
  Buffer pool                               (DFT_MON_BUFPOOL) = ON
  Lock                                     (DFT_MON_LOCK) = ON
  Sort                                     (DFT_MON_SORT) = ON

BLUEBOX2.nicelab.de  15.250.250.243  perl "C:\Program Files\HP OpenView\Installed Packages\{790C06B4-8
```

Upon the end, the user is asked to save the output in a file. This question is given regardless if the output has been quit before or not.

### Show Snapshot

The Show Snapshot application opens a terminal window and displays the complete snapshot data of a selectable database, as is used as the basis for performance metric analysis.

When started, it first asks for the DB2 instance as explained earlier.

After that, we browse through the databases belonging to this instance and for each we ask whether a snapshot should be created or not.

Respond with "y" or "n", followed by <RETURN> to select the database of interest.

If a database has been selected, DB2 is requested by the script and provides the data in the terminal window.



Since this output may be lengthy, so we provide a paged output with 20 lines displayed before requesting user input to continue or stop. Note that the output window (both Motif and Java) also provides a scrollbar to move through the output, but that may be too limited in many cases (the snapshot consists of several hundred lines!).

In order to continue browsing through the snapshot, simply press <RETURN>.

If you want to cancel, hit <Q> and <RETURN>.

Regardless if cancelled or finished at the end of the snapshot, the DB2SPI asks if that snapshot should be saved as a text file:

The file name proposed contains the names of instance and database to allow an easy identification in the file system.

Press <RETURN> to close the window when done.

This is a sample session running the "Show Snapshot" application:

```
Please select an instance on dengue
```

```
(to abort press 0)
```

1. db2inst1
2. db2inst4
3. db2inst7

```
>2
```

```
Snapshot desired for database IN4_DB1 [yn]?>n
```

```
Snapshot desired for database IN4_DB2 [yn]?>y
```

#### Database Connection Information

```
Database server          = DB2/HPUX 8.1.0
SQL authorization ID     = DB2INST4
Local database alias     = IN4_DB2
```

#### Database Manager Configuration

```
Node type = Enterprise Server Edition with local and remote
clients
```

```
Database manager configuration release level          = 0x0a00
```

```
CPU speed (millisec/instruction)                    (CPUSPEED) = 3.424496e-
06
```

```
Communications bandwidth (MB/sec)                    (COMM_BANDWIDTH) =
1.000000e+00
```

```

Max number of concurrently active databases      (NUMDB) = 8
Data Links support                             (DATA LINKS) = NO
Federated Database System Support              (FEDERATED) = NO
Transaction processor monitor name             (TP_MON_NAME) =
Hit RETURN to continue or Q to quit ...<RETURN>

Default charge-back account                    (DFT_ACCOUNT_STR) =

Java Development Kit installation path         (JDK_PATH) =
/opt/java1.3

Diagnostic error capture level                 (DIAGLEVEL) = 3
Notify Level                                  (NOTIFYLEVEL) = 3
Diagnostic data directory path                 (DIAGPATH) =
/home/db2inst4/sqllib/db2dump

Default database monitor switches

Buffer pool                                   (DFT_MON_BUFPOOL) = ON
Lock                                          (DFT_MON_LOCK) = ON
Sort                                          (DFT_MON_SORT) = ON
Statement                                    (DFT_MON_STMT) = ON
Table                                        (DFT_MON_TABLE) = ON
Timestamp                                   (DFT_MON_TIMESTAMP) = ON
Unit of work                                 (DFT_MON_UOW) = ON
Monitor health of instance and databases     (HEALTH_MON) = OFF

SYSADM group name                            (SYSADM_GROUP) = DB2GRP1
SYSCTRL group name                           (SYSCTRL_GROUP) =
Hit RETURN to continue or Q to quit ...q
Do you want to save snapshot as /tmp/db2inst4_IN4_DB2.txt? [yn]>y

The application: "db2s_showsnap.pl" has terminated.
Please press RETURN to close the window.

```

## Simple Access to DB2

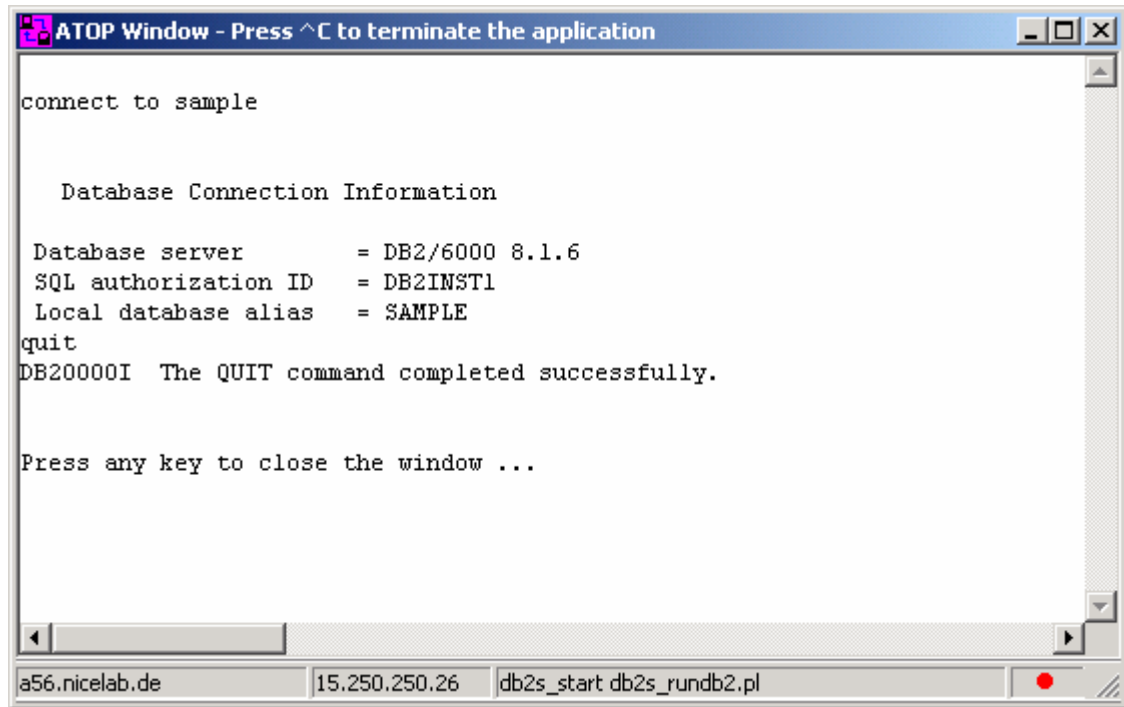
### DB2 CLP

The DB2 program opens a command shell that provides interactive access to the DB2 command line processor. Enter **quit** to leave the program and close the window.

The following picture shows a sample of running DB2 in an OVO/Windows environment:



**Figure 20: DB2 CLP session an ATOP window**



### Instance Start

The `Instance Start` application attempts to start the selected DB2 instance and displays progress in a terminal window. If the database is already running, the DB2SPI returns an error message. Press **<RETURN>** to close the window.

Note that due to the asynchronous nature of the DB2 startup, the DB2SPI can only recognize problems during the triggering of the startup procedure. Any problems in this phase are logged in the DB2 log files and, as a consequence, detected by the DB2SPI log-file monitor.



### Instance Stop

The `Instance Stop` application attempts to stop the selected DB2 instance and displays progress in a terminal window. If the database is already down, the DB2SPI returns an error message. Press **<RETURN>** to close the window.

Note, that due to the asynchronous nature of the DB2 shutdown, we can only recognize problems during the triggering of the shutdown procedure. Any problems in this phase, however, are logged to the DB2 log file and detected by the DB2SPI log-file monitor.



## Advanced Management Tools

A separate application group contains a set of advanced management tools that allow almost all administrative tasks that could be performed on a DB2 server, ranging from backup via data management to instance, database, tablespace and table management.

In principle, all these commands could also be typed and executed in the DB2 command line processor. The DB2SPI tools, however, make it much easier to achieve results timely as we check the correctness of the statements and allow correction before they are executed.



Note that using these tools can affect the integrity of your database, and you should be well trained in DB2 administration when executing such tasks. You can achieve these results also by entering DB2 commands or by using the DB2 command line processor.

HP/NICE are not liable for adverse results caused by inappropriate use.

### Configurable Tools Basics

Each DB2 administration command is created internally in a step-by-step approach. We call these tools "flexible", as we can define almost any command with the same method of assembling fixed, variable and optional components of a command.

Depending on the command, one of the following user actions are requested:

Selection of one item from a selection list

Entry of a value

Omission of optional parameters

At most places, the user may go back to the previous step in case had had made an error. This is achieved by entering "\b" where offered.

Also, cancellation is possible where "\a" is allowed for entry.

Whenever special keys are available for a certain operation, they are prompted in the dialogue window.

If the command is assembled completely, it is shown on the screen and its execution must be confirmed (or denied) by the user.

Upon the end of the execution, the user may even decide if the output provided shall be saved to disk or not. This file may be helpful when DB2 errors are encountered that need a deeper investigation or when the result is required for other purposes.



## DB2 Management Tool Areas

There are ten different areas for the flexible management tools. Table 13: shows the different areas and the tools embedded inside them.

**Table 14: Flexible Tools**

<b>Management Area</b>	<b>Available Tools</b>
Application Management	List Applications List DCS Applications Force Applications Rebind Rebind All Packages
Backup / Restore	Check Backup Backup Database Restore Database Rollforward Database
Data Management	Export Import
Database Management	Catalog Database Catalog DCS Database Create Database Create Sample Database Activate Database Reset Database Configuration Restart Database Uncatalog Database Uncatalog DCS Database Alter Bufferpool
Database Migration	Check Migration Migrate Database
Instance Management	List Instances Reset Database Manager Configuration Reset Administrative Server Configuration
Miscellaneous	Get Monitor Switches Prune History Prune Logfile
Node Management	Lists Node Directory List Nodegroups List Nodes Verify Node Change Partition Server Configuration Add Node Redistribute Nodegroups

Management Area	Available Tools
Table Management	Reorganize Table Reorg Check Runstats
Tablespace Management	List Tablespaces List Tablespace Containers Quiesces Tablespaces Alter Tablespaces

### Sample Flexible Tool Dialogue

A typical dialogue of an application looks as follows:

```

Select one application
(to abort press 0)

      1.      List applications
      2.      List DCS Applications
      3.      Force Applications
      4.      Rebind
      5.      RebindAllPkgs

>1

Do you want to specify the database name?
('0' - abort, 'b' - back)

      1.      Yes
      2.      No

>1

Please select a database for DB2
('0' - abort, 'b' - back)

      1.      DB2_DB1
      2.      DB2_DB2
      3.      DB2_DB3
      4.      DB2_DB4
      5.      DB2_DB5

```

6. DB2\_DB6
7. DB2\_DB7
8. DB2\_DB8
9. DB2\_DB9
10. DB2\_DB10
11. SAMPLE

>11

Please select the nodes that you want to list the applications for.

('0' - abort, 'b' - back)

1. specific node
2. all nodes

>1

Please enter the node number for which you would like to list applications:

('a' - abort, 'b' - back)

>1

Please select the type of information you would like to view:

('0' - abort, 'b' - back)

1. Basic information
2. Detailed information

>1

COMMAND: LIST APPLICATIONS FOR DATABASE SAMPLE AT NODE 1

The command will be executed on instance 'DB2'

('0' - abort)

1. Run the command
2. Return to the previous step

>1

SQL1610N The Database System Monitor input parameter "data->iNodeNumber" is invalid.

The application: "perl -S db2s\_flexapp.pl -s applmgmt" has terminated.

Please press RETURN to close the window.

## Graphical Data Presentation Utilities

The DB2SPI supports various ways to present collected performance data in a graphical way:

Embedded graphing component in OVO/Windows

OVP (available on HP-UX, Solaris, Windows)

In the next sections we describe the various methods in detail.

OV Performance Manager (OVP) and the OVO/Windows embedded graphing tool can be used to view data, depending on the format they are stored (MWA format or CODA format) as explained below.

OVP is the recommended tool as it supports all data formats.

### Executing embedded Graphing

With OVO/Windows, we can only view performance data that have been collected in CODA data stores, which is default for Windows managed nodes, but non-standard for Unix managed nodes. This must be kept in mind when trying to view graphs in OVO/Windows.

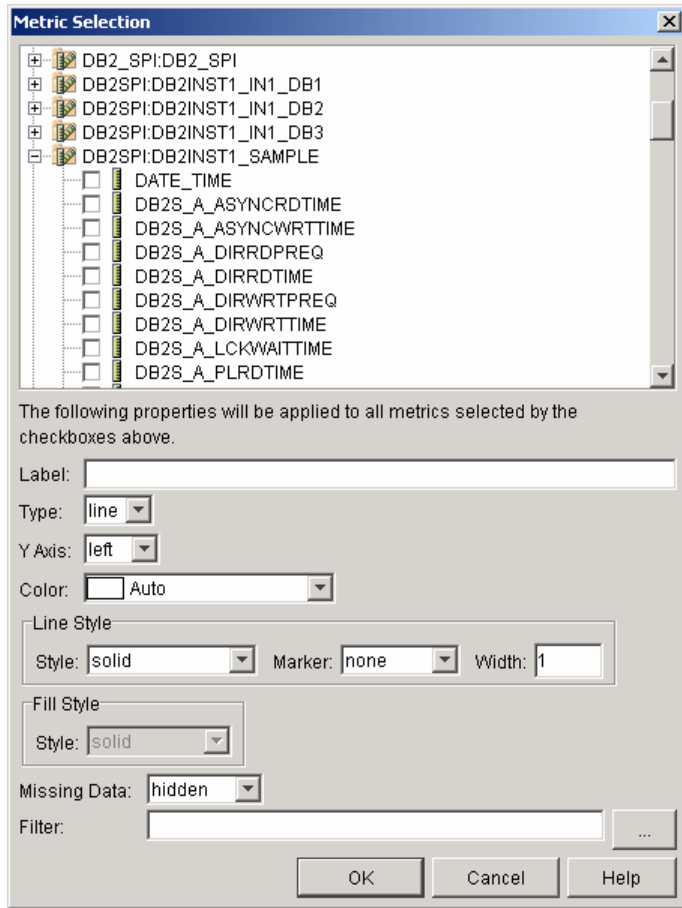
Creating these graphs is straightforward with the standard procedures available in OVO/Windows.

There is only one place where special attention might be necessary, definition of the metrics to be displayed.

The selection tree typically shows a lot of individual data sources, and the user must make sure that the proper source is selected. All DB2SPI data sources are named "DB2\_perf\_<instance>\_<database>" and metrics must be selected as subtrees of the desired instance / database.

A sample for this selection window is given in the OVP section below (see

Figure 24: Metric selection for OVP graphs

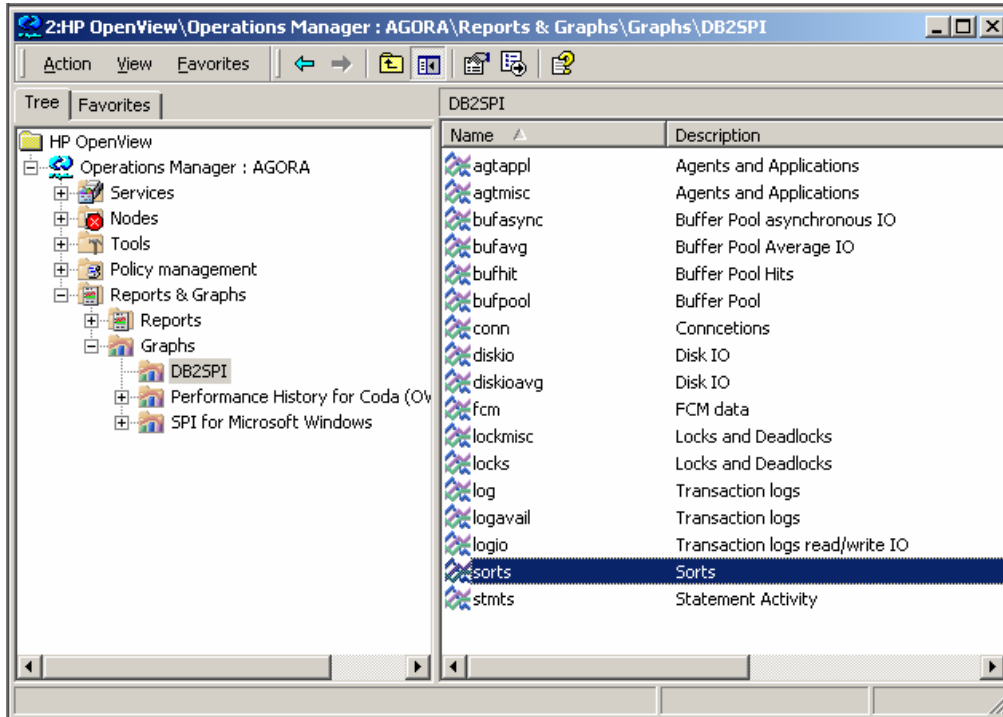


).

### Predefined Graphs for embedded Graphing

In the Reports and Graphs section of the task tree in OVO/Windows we find a list of predefined graphs as listed in the next figure.

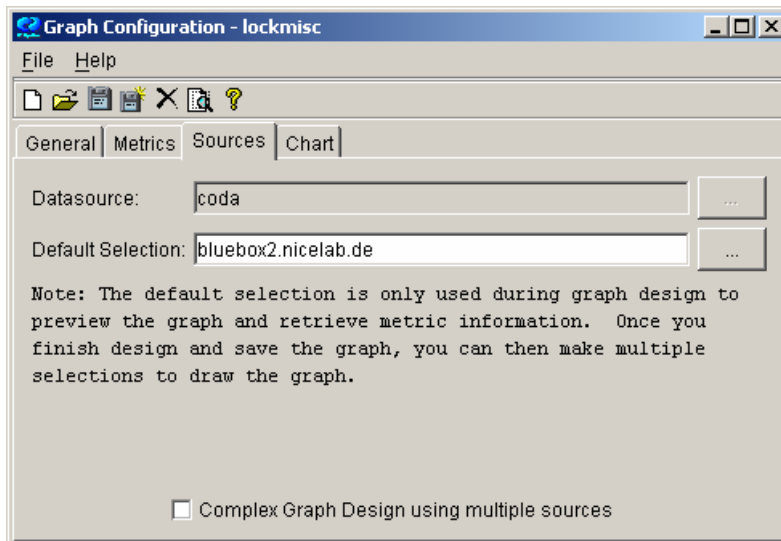
**Figure 21: Predefined DB2SPI Graphs**



In order to use these graphs, you have to select one of them and open its "Properties" sheet, e.g. via clicking the right mouse button.

In the "Properties" you have to define a system where your data are to be picked up via the "Source" tab, as shown next:

**Figure 22: Source determination for the predefined graphs**



Since the "Metrics" are predefined, all information to draw the graph is available.

### Running OVPM interactively

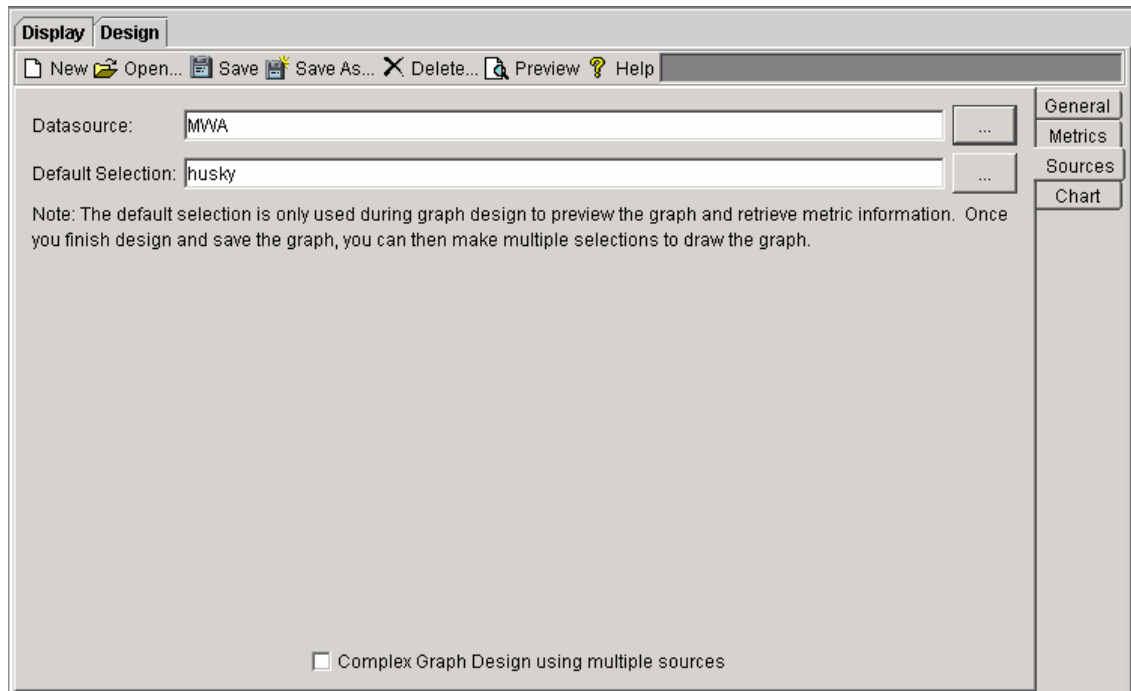
OVPM must be installed on any system in the network, but it must be able to access the DB2 servers and the performance data stored in OVPA / CODA format on these node(s).

Assuming that OVPM is installed with the standard IP port, the user may run an interactive session from any supported web browser by accessing the URL [http://<ovpm\\_server>:8080/OVPM](http://<ovpm_server>:8080/OVPM)

Within OVPM, the must take the following steps to create custom graphs:

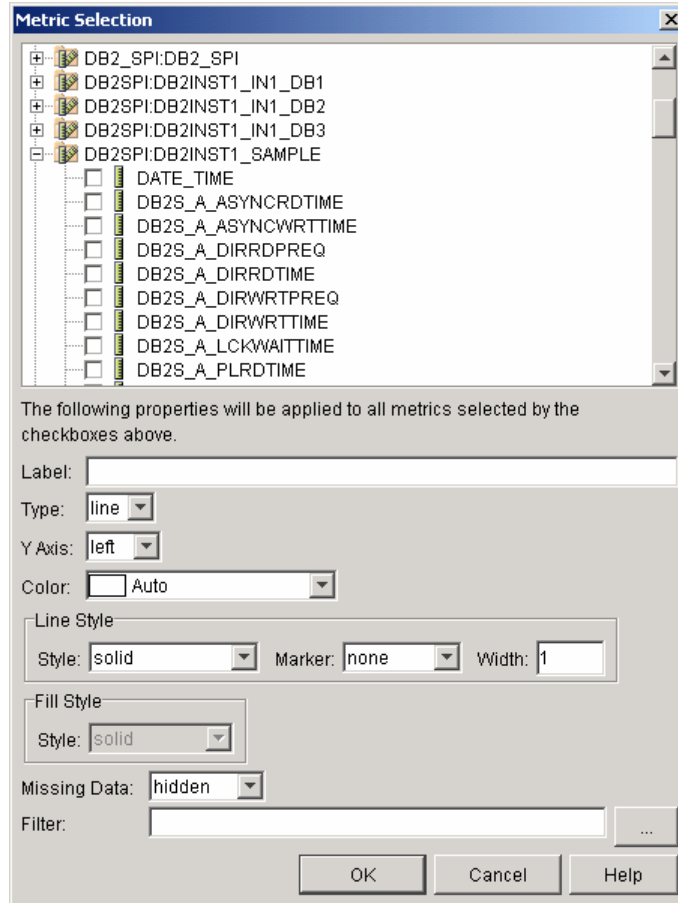
- 1 Enter the "Design" tab in the GUI (in the following we are using the Java interface)
- 2 Define a data source in the "Sources" sheet

**Figure 23:OVPM data source definition**



- 3 Select desired metrics via the "metrics" sheet. Pressing "Add" at the bottom of this sheet shows all DB2SPI data stores found on the selected system. Unfold the metrics tree of the desired DB2 instance and database.

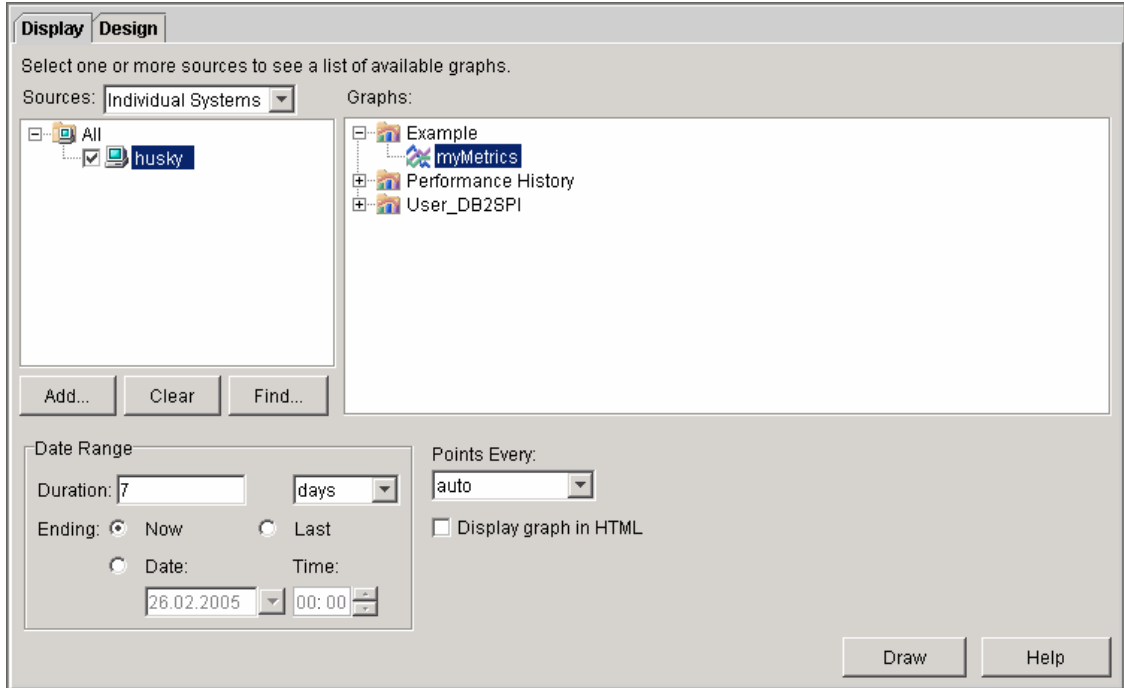
Figure 24: Metric selection for OVPM graphs



- 1 The metric selection can be previewed directly from the "Design" tab, or saved and displayed via the "Display" tab.

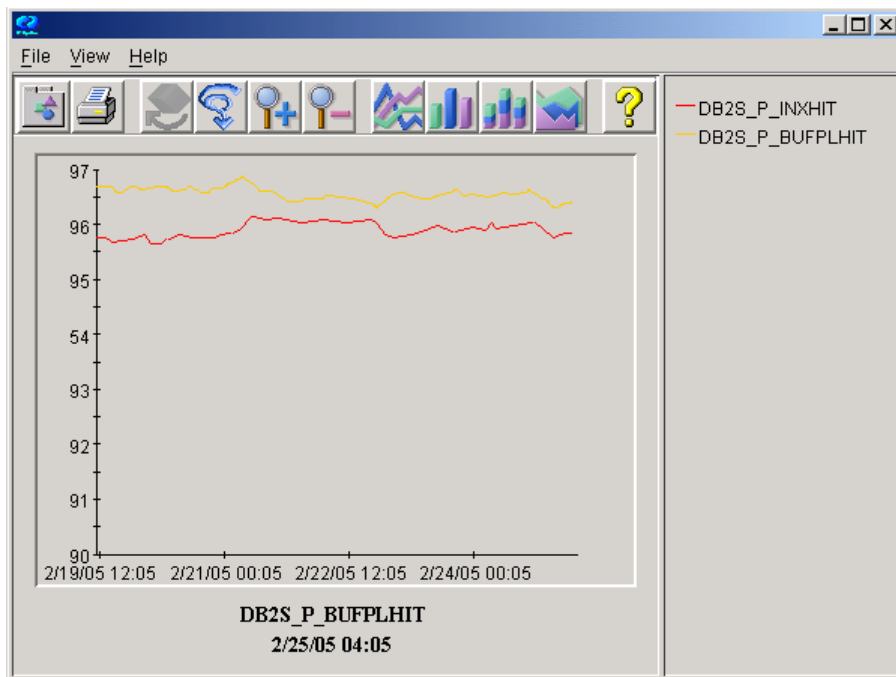


**Figure 25: Display tab with new graph selected**



A new window opens and displays the data chosen.

**Figure 26: OVPM Graph**



# 9 Concepts and Architecture

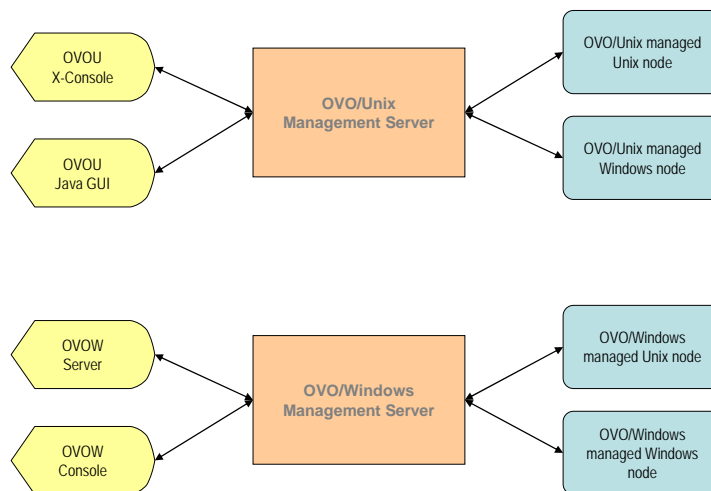
This section describes the general architecture and processing of the DB2SPI.

## ATOP Communication Layer

ATOP is a component of the DB2SPI that helps to execute interactive applications on both Unix and Windows managed nodes and interact with them from OVO/Unix Motif or Java GUI, or from the OVO/Windows management console in absolutely the same way.

Internally, a communication channel is created separate from the OVO communication as can be seen in Figure 27.

**Figure 28: ATOP Architecture underlying DB2SPI**



## ATOP Configuration Settings

ATOP uses a separate IP connection between the managed nodes and the management server and from the management server to Java GUI stations / management consoles. This communication must be consistent throughout the management domain.

The configuration values are stored in the configuration files `atop.cfg` on the managed nodes and `atopsvr.cfg` on the management server.

The file `atopsvr.cfg` is found in the directories

OVO/Unix:  
/opt/OV/atop/bin

OVO/Windows:  
\\Program Files\\HP OpenView\\bin\\DB2SPI

on the management server.

For deployment to the managed nodes, copies of `atop.cfg` are kept in all supported platform-specific directories for the managed nodes, hence


OVO/Unix:  
/var/opt/OV/share/databases/OpC/mgd\_node/customer/<...>/cmds

OVO/Windows:  
\\Program Files\\HP OpenView\\Instrumentation\\<platform>\\DB2SPI

on the management server.

On Microsoft Windows based OVO/Unix Java display stations or OVO/Windows management consoles, the file can be found in

\\Program Files\\HP OpenView\\bin\\DB2SPI

 **Note:** Whenever changes need to be made to the ATOP configuration file, especially regarding the port information, this must be re-distributed to the managed nodes and display stations.

### Default Settings and their Modification

The default configuration of ATOP consists of the following settings:

```
# -----  
# Configuration file for ATOP2 server 'atopsrv'.  
#  
# -----  
  
ATOP_CFG_LOGLEVEL      = 1  
ATOP_CFG_SERVERPORT    = 55551  
ATOP_CFG_CLIENTPORT    = 0  
ATOP_CFG_LANGUAGE      = us  
ATOP_CFG_QUEUELEN      = 10
```

---

There is one important field, the `ATOP_SERVERPORT`, which acts as the key for all successful communication between the managed nodes and the display stations. This port must be enabled in the IP network connecting the systems.

If this should not be suitable for your environment, please change the configuration with an editor on the management server and make sure to distribute it to all nodes in the management domain (managed nodes using ATOP, Java GUI display stations, OVO/Windows consoles) as described next.

## Distributing changed ATOP Configuration Data

ATOP configuration changes must be distributed within the managed environment to make sure communication can be committed, especially if port numbers should be changed.

Three areas therefore require the updated information.

- Management Server

The ATOP server executing there consumes the "master copy" of the ATOP configuration file and needs no special attention.

- In OVO/Unix, it is a registered OV service it needs to be restarted after the configuration file has been changed:

In a terminal session on the management server, enter

```
ovstop atop_server
```

```
ovstart atop_server
```

to achieve this. Make sure you have been successful by entering

```
ovstatus atop_server
```

- In OVO/Windows, re-start the "ATOP2 Server" service set up during installation.



Note: No ATOP application windows should be open at the time of re-starting the ATOP server; depending on the configuration changes that might lead to unpredictable results.

- Managed Nodes

These nodes get updated with the regular distribution mechanism of OVO, i.e., via "Install & Update Software & Configuration" from the OVO administrator GUI, and hence it consumes all data that are in the respective repository. So, in order to get the configuration data to the nodes we must make sure that they are consistent, especially with regards to the port number, in those platform specific repositories. Edit the `atop.cfg` files there and do the "Install & Update Software & Configuration" from the OVO administrator GUI afterwards to bet the data distributed to all managed nodes.

- Java Display Stations of OVO/Unix and OVO/Windows Consoles

For the Java Display Stations and OVO/Windows consoles there is no intrinsic update method today.

So, when changes are done on the management server, the configuration file `/opt/OV/db2spi/bin/atopsrv.cfg` must be transferred manually to `\Program Files\HP OpenView\bin\DB2SPI`

or these changes must be made locally in a consistent manner.

Do not forget to re-start the "ATOP2 Server" service on Windows systems after a change to the ATOP configuration file.

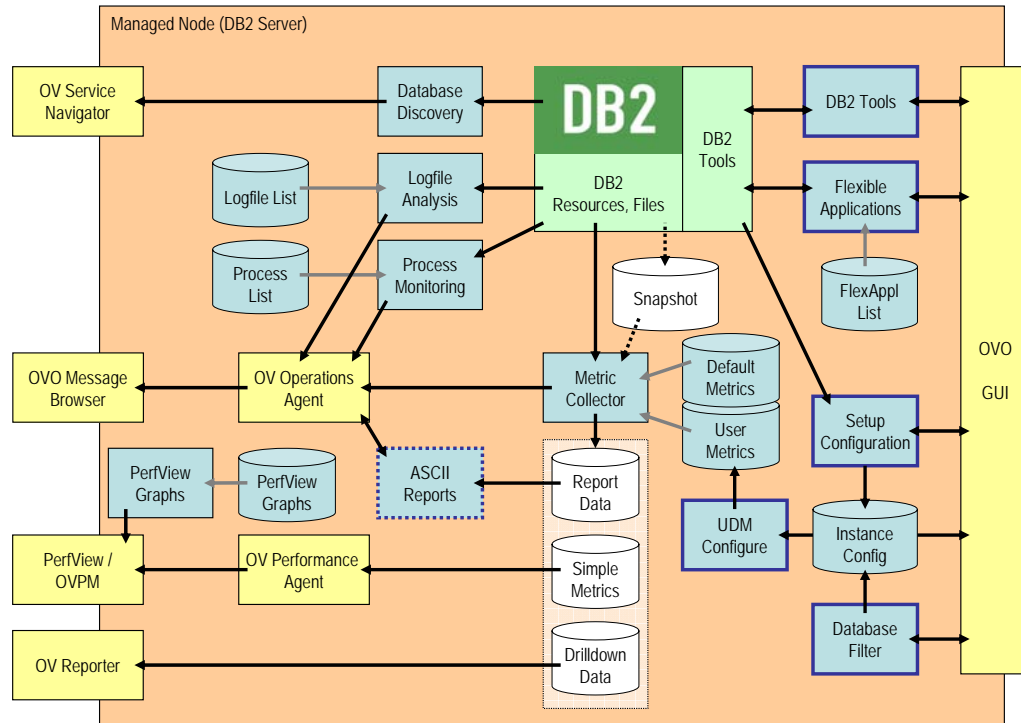
## A Note on Strange Characters

Sometimes strange characters may be shown in ATOP windows, especially when executing tools on Unix systems. This is not a defect, just some terminal test sequences (tset, ttytype etc.) that are launched when sessions are switched and the user profile requests such action.

## DB2SPI Internal Architecture

Taking a closer look at the DB2SPI modules and configuration data, we get the following picture:

**Figure 29: DB2SPI Internal Architecture**



In the following sections we will describe in detail how the different monitoring areas work and interact with each other.

## Support of non-Root Agents (Unix Managed Nodes)

A special functionality (not shown in the picture) is the internal "su" functionality used for the switch of DB2 environments. Whenever DB2 is to be accessed we do so per instance to have the proper environmental data (DB2 refers to some of these settings when calling, for example, the command line processor).

When non-root operation of the agent is enabled, we require a special "db2s\_sudo" program instead of the simple "su" to facilitate this environmental switch without a password. This program is secured against misuse by requiring a predefined list of users that we may switch to, /etc/db2spi.su. This file must be edited to contain the correct information. This is not automated and must be performed as 'root' for security reasons.

## Monitoring Log Files

### DB2 Log Files

Various log files are used by DB2 to note status changes, problems or other information. With the DB2SPI we are isolating the important areas from them and forward these as events to the OVO message browser.

## Diagnostic Log File

Prior to Version B.03.02 the log file `db2diag.log` was monitored for all instances. This monitoring has been obsoleted due to IBM's new policy of storing only support information in this log file. All administrative information will be written to the Administration log file.

## Administration Log File

With DB2 8.1 IBM introduced a new log file in Unix environments holding important events, the administration log file. As with the diagnostic log file, it exists once per instance.

The structure of the administration log file is pretty similar to the diagnostic log file, but applies stricter rules to contents and format of the entries.

In Windows environments the administration log is provided in the Windows event log.

In these administration log files or administration event logs, we are looking for more than 120 specific event entries.

## Replication Log Files

Replication log files are written rapidly by DB2, and we are monitoring them all for status hints if replication monitoring has been activated during the "Config Setup".

A dedicated logfile processing script is used for it, as there is no preprocessing necessary as with the diagnostic log files.

## Log File Size Monitoring

Alerts are created when diagnostic or administration log files exceed a predefined size. By default, these are 200 kb.

For replication log files, if enabled, the limit is set to 1.5 Mb before warnings will be given.

## DB2SPI's own Log File

There is a log file for internal logging of the DB2SPI, `db2spi.log`. Important messages are created from this log file by a separate log file template provided with the DB2SPI.

## Log File Size Monitoring

Alerts are created when the DB2SPI log file (or a possibly existing trace file, `db2s_trace.log`) exceeds a predefined size. By default, these are 100 kb.

## Monitoring DB2 Processes

### What is Process Monitoring?

#### Monitoring Processes in UNIX Environments

DB2 servers running on UNIX systems show up as a number of processes executing. Process monitoring therefore means to check these processes for availability and operational status.

The result of these checks will cause events shown up in the message browser if there are differences to the expected state for the respective environment. Also, the OVO service tree is updated when such status changes are detected.

On UNIX, the processes are split up among the various instance sessions and the system session. Even among different UNIX systems, process setup, number and distribution vary.

## Monitoring Processes or Services in Windows Environments

DB2 servers running on Microsoft Windows systems show up as a bunch of services executing and their associated processes. Process monitoring therefore means to check these services and / or the associated processes for availability and operational status.

In the DB2SPI we are checking the processes rather than the associated services.

The result of these checks may cause events shown up in the message browser if there are differences to the expected state for the respective environment. Also, the OVO service tree is updated when such status changes are detected.


## DB2 Version and Edition Dependency

To make it more complicated, the different DB2 editions (personal, workgroup, enterprise, extended enterprise or enterprise server) and supported versions (DB2 8.1 and 8.2) cause different sets of processes to execute.

## DB2SPI's Process Configuration File

The rules how many processes of what kind and in whatever session should be executing in a well-behaved DB2 system is stored in an XML configuration file supplied with the DB2SPI.

Upon deployment, this file is pretty bulky as it contains all platform, DB2 version and edition dependencies. When executing the `Config Setup` application, this file is reduced to the set of prescriptions valid for the actual DB2 server.

 Whenever a DB2 server is upgraded (e.g. from 7.x to 8.1), the `Config Setup` must be executed again, because the DB2SPI instance configuration file and the process configuration file must be made aware of the currently installed DB2.

An overview of the processes that are monitored with DB2SPI in the various instances can be found in the Appendix on page 130.

## Events from Process Monitoring

### Problems detected

DB2SPI Process Monitoring is executed every ten minutes by default and is able to detect the following malfunctions and reports them to the OVO management server:

The DB2SPI provides detailed messages what is wrong with the process setup.

We distinguish between

- missing processes
- excess processes

for the following session environments (Unix):

- System session
- Administration Server session
- Instance session

As there is only one session (system session) on Windows DB2 server, no direct relation to the instances can be determined. Process counting therefore is restricted to a comparison of the number of processes of the various kinds.



Due to this reason, missing processes cannot be determined with certainty if not all instances on a DB2 server are managed.

### Common Properties

All events from process monitoring belong to the OVO message group DB2.

Missing processes typically are signalled as `Critical` or `Major` events with the object name being the missing process.

Excess processes are `Warnings` only.

There are no events when the number of processes is correct. Hence, the event must be acknowledged manually in this case when the problem has been cleared.

### Service Interaction

Process monitoring events affect the service tree at the instance level.

## Performance Data Collection (Standard Metrics)

We learn how performance data are collected and processed by the DB2SPI and how the general information flow can be affected by the DB2SPI Administrator.

Performance data can be collected in either OVPA (MWA) or CODA (embedded performance collection) data stores. By default, OVPA (MWA) is used for Unix managed nodes and CODA for Windows managed nodes.

In "Format of the Data Store" on page 100 we describe how these defaults can be changed.

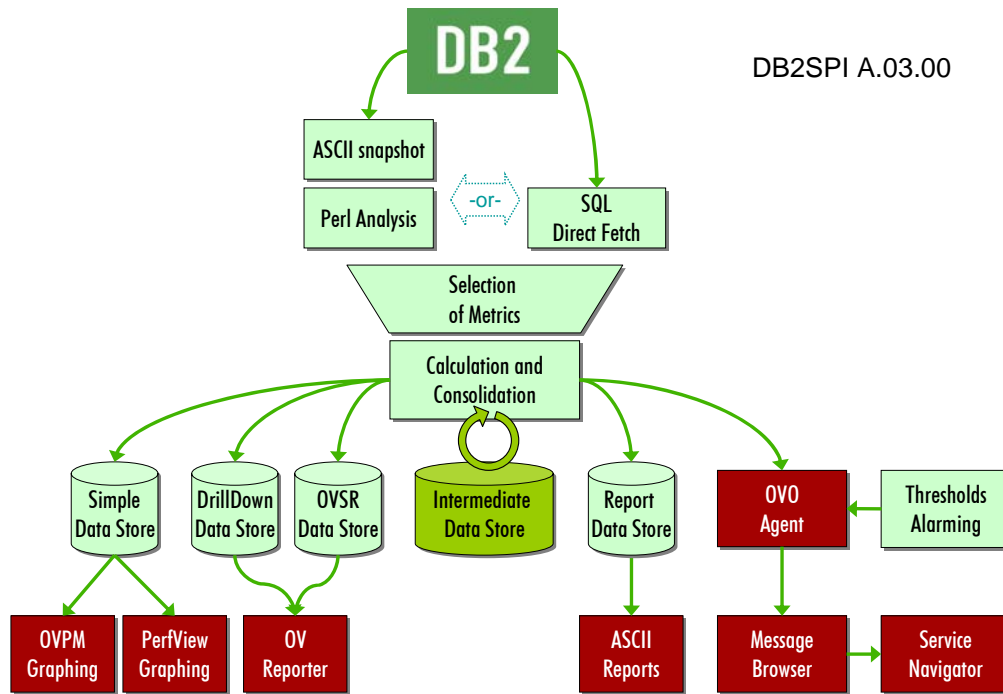
In the following, we will discuss metric storage regardless of the format, unless specifics must be considered.

### General Data Flow

The DB2SPI is able to collect a big amount of performance data that are supplied by DB2. The collection is done as shown in the following picture:



Figure 30: Data flow for DB2 metric data



The data flow can be described as follows:

### Collection of Source Data

DB2 can be configured by their internal "monitor switches" to collect performance information in some internal tables. We retrieve them in one of two ways, using external or internal requests.

With external requests we demand the creation of ASCII snapshots. These are files that contain all current performance values with some descriptive text, which we afterwards read and analyze to determine the respective performance values.

Depending on the configuration (like the number of tablespaces) or operation (currently connected applications, for example) this can be a lengthy and CPU consuming operation.

However, this method can be applied to all DB2 versions, and it can be adapted easily, since the analysis and calculation is done in Perl. This method must be employed when collecting data for User Defined Metrics (UDM).

With internal requests we obtain the data directly from the DB2 database by submitting proper function calls ("embedded SQL"). This provides direct access to the data source with maximum throughput, but is less flexible than the Perl approach.

Besides that, we can use this only for DB2 version 8.1 and higher.

### Data Processing

Despite the way how raw data are obtained, their processing is similar:

Raw data are taken for the calculation of valuable, derived information, like percentages, ratios etc.

Snapshot data are requested by the DB2SPI and are stored temporarily for proper analysis.

Metric values are retrieved from these snapshot files by proper filtering and calculation.

These metric values can be forwarded to OVO and/or OVPA/CODA

The OVO agent is used to perform threshold monitoring and provides alerts if a metric is outside the valid range

If available and enabled, the OVPA/CODA agent stores these metrics for later viewing with PerfView, OVPM or OVO/Windows Graphing and for reporting with OV Reporter

### Affecting the Metric Data Processing

There are three switches that affect processing of the performance data:

- 1 First of all, snapshot creation with the "DB2 monitor switches" can be disabled and enabled with the "Snapshot Enable" / "Snapshot Disable" tools. If disabled, the database is not requested not to provide any performance data. This minimizes the system load, but also inhibits any kind of monitoring performance, availability etc.

Switching "snapshot DB2 monitor switches" of DB2 on and off requires a restart of the database, and this functionality is provided within the tool, and this is a pretty invasive step. This is because we change the default settings rather than the current ones for the given database.

- 2 Second, OVO data forwarding can be prohibited or enacted by another switch application "OPCMON Enable / OPCMON Disable". This is useful (or necessary) if the OVO monitor agent shall not be used for threshold monitoring and alarming, but data shall be collected for PerfView OV Performance and / or OV Reporter.
- 3 Third, OVPA/CODA data forwarding can be prohibited or enacted by another switch application pair of tools ("MWA Enable / Disable"). This is useful (or necessary) if OVPA/CODA is not available or not installed at all on the DB2 server.

When executing only "MWA Disable", threshold monitoring still is active and alerting can be achieved via the OVO monitor agent.

Primary performance data are collected by DB2 itself when snapshot collection is enabled. Since this gathering requires resources, this will often be disabled on DB2 servers while they are not managed systems.

The installation of the DB2SPI does not change any settings of the DB2 intrinsic collection.

Before the DB2SPI can monitor any DB2 metrics, you have to ensure that the collection of DB2 intrinsic performance data is started on the DB2 server. You can do this with the "Snapshot Enable" tool in the "DB2SPI Admin" application group.



The collection of performance data works on an instance oriented basis.

This means that for every instance the collection of performance data must be switched on / off explicitly by choosing the appropriate instance in the upcoming menu.

### Metric Collection and Resource Consumption

The metric collection can be "expensive" in terms of requiring system resources.

Thus, it might desirable to adjust the metric collection to limit the impact upon the system if possible. The following points should act as a guideline where to look into and what to consider, but there is not "best solution", as it always depends on the needs and desires of each customer.

In order to reduce the workload from the managed node required for metric processing, you might:

- Read Reference Guide carefully and decide on the importance of each metric
- Call less metrics with db2s\_dbmon.pl script in the scheduling policies
- Add new scheduling templates to call some metrics less often
- Forward less metrics to opcmn (add NO\_OVO in db2s\_metrics.\*.cfg)

## Naming Scheme for Metrics

The naming scheme for the metrics and associated OVO monitor templates is consistent and as self-explaining as possible.

Example: DB2\_0172p\_OpnLocCursBlk\_ap

Each metric consists of a prefix (DB2\_), a three-digit number (e.g. 017), a one-digit level indicator (e.g. 2), a flag character (e.g. "p") and the meaning in abbreviated form.

The abbreviation of the meaning is required due to MeasureWare/OVPA restrictions – no more than 20 characters are allowed to identify metrics in MeasureWare/OVPA, and some of them are already reserved for the product key. All names also contain a postfix, which indicates the level purpose.

For the flag character the following list applies:

**Table 15**

Key	Meaning
a	average
c	count
g	gauge
i	information
p	percentage
r	ratio
w	watermark

## Amount of Data Collected

Since the A/B.02.00 release of the DB2SPI we are gathering 135 different values directly or derived from original DB2 performance monitor data. A comprehensive list can be found in the DB2SPI Reference Guide.

To store the data collected, the following disk space must be available (assuming one year of data):

- Reporter OVPA data: 59 Mb per node
- Graphing OVPA data: 4 Mb per instance/database
- Drilldown data 47 Mb per instance/database/tablespace

Note that these are maximum values of disk space to the storage.

*Example:*

*If you are managing 3 instances with a total of 10 databases and 23 tablespaces, you need*

$$59 \text{ Mb} + 10 * 4 \text{ Mb} + 23 * 47 \text{ Mb} = 1180 \text{ Mb disk space.}$$

This gross amount can only be affected by reducing the data collection rate, not by removing certain metrics from being collected.

## Configuring Data Collection

Data collection is configured in a three-step approach:

First, we must decide about the data format. This depends on the tools we want to apply for viewing and processing the data and applies to all data collection installed on the respective managed node (i.e., to all SPIs). The tools that might be used are OVPA or CODA.

Next, data are provided by DB2 snapshot monitors at predefined rates between ten and thirty minutes. This is done in the schedule templates which start the metric data collection.

Finally, the metric values created this way are forwarded to OVPA/CODA in a common time slice (every five minutes), regardless of the collection repetition.

Thus, the common granularity of the data is determined by:

- DB2 snapshot creation repetition and analysis
- DB2SPI data forwarding to OVPA/CODA

### Format of the Data Store

DB2SPI uses the DSIDDF tools to store data for OVPA/CODA.

▶ These tools are not installed automatically with the DB2SPI, but must be available when the DB2SPI configuration ("Config Setup") is performed.

Right now, there are no tools in the DB2SPI to determine specific configuration of the data storage type. The explanation given here should help the user to define specific setups by themselves if needed. Note that these settings affect all other SPIs as well.

These tools contain a predefined logic about default storage formats, depending on the platform they are just operating:

On Unix systems, OVPA format is the default data source

On Windows systems, CODA format is the default data source.

These defaults can be overridden by providing a special file, `nocoda.opt`, in a specific place in conjunction with the existence (installation) of certain tools.

#### Case 1: Determine CODA Availability

To determine if CODA is installed, the code looks for the CODA executable in platform dependent locations.

On AIX, the code looks for `/usr/lpp/OV/bin/coda`.

On all other UNIX platforms, the code looks for `/opt/OV/bin/coda`.

On Windows, the code uses the NT Registry key [HKEY\_LOCAL\_MACHINE\SOFTWARE\Hewlett-Packard\HP OpenView\AgentInstallDir]. The code adds the bin directory to the registry key value.

For example:

```
C:\Program Files\HP OpenView\Installed Packages\{790C06B4-844E-11D2-972B-080009EF8C2A}\bin\coda.exe
```

#### Case 2: `nocoda.opt` is given

To determine if the `datasource` is overridden, the code looks at the contents of the `nocoda.opt` file. The location of this file is platform dependent.

On AIX, the code looks for `/var/lpp/OV/conf/dsi2ddf/nocoda.opt`.

On all other Unix platforms, the code looks for `/var/opt/OV/conf/dsi2ddf/nocoda.opt`.

On Windows, the code uses the NT Registry key

[HKEY\_LOCAL\_MACHINE\SOFTWARE\Hewlett-Packard\HP

OpenView\AgentDataDir]. The code adds the `conf\dsi2ddf` directory to the registry key value.

For example:

```
C:\Program Files\HP OpenView\Installed Packages\{790C06B4-844E-11D2-972B-080009EF8C2A}\conf\dsi2ddf\nocoda.opt.
```

With `nocoda.opt` given, its contents could even be used to determine different types for different data sources, as listed below in the decision tree.

### Case 3: `nocoda.opt` is not there

If the `nocoda.opt` file is not on the system, the code determines if `ddfcomp` is running from the OVO/Windows location.

On AIX, the OVO/Windows location is `/var/lpp/OV/instrumentation/ddfcomp`.

On all other UNIX platforms, the OVO/Windows location is `/var/opt/OV/bin/instrumentation/ddfcomp`.

On Windows, the OVO/Windows location is any path that includes “instrumentation” or its short form “instru~”.



The DB2SPI requires the installation of `ddfcomp` on the managed node. If it should not exist during setup, no metric data will be stored for reporting or graphing.

The code uses platform dependent methods to determine if OVPA is installed.

On UNIX platforms, the code looks for `/var/opt/perf/perflbd.rc`. If the file exists, OVPA is installed.

On Windows, the code uses the NT Registry key

[HKEY\_LOCAL\_MACHINE\SOFTWARE\Hewlett-Packard\MeasureWare

Agent\CurrentVersion\CommonDataPath]. If the NT Registry key exists, then OVPA is installed.

### DSI2DDF Decision Tree

All together, the DSI2DDF Tools perform the following decision for CODA / OVPA storage:

is CODA installed?		
yes: is data source overridden? (see below)		no:
yes: use MWA/OVPA	no: use CODA	use MWA/OVPA

To determine if a data source is overridden, the following applies:

does nocoda.opt exist?						
yes does it contain data?				no does ddfcomp exist?		
yes			no	yes	no	
is it "ALL"?		is it the current data source?			does OVPA exist?	
use OVPA		yes use OVPA	no use CODA	use CODA	yes use OVPA	no use CODA

### Data Collection Scheduling

Data collection means starting a snapshot for the desired database and analyzing the response supplied by DB2.

The DB2SPI provides two default templates for appropriate data collection, implemented as schedule templates named `db2s_metric_10m` and `db2s_metric_30m`.

The desired metrics for each time resolution are specified in the command line of the script called by these schedule templates by their number. These numbers can constitute a list of comma-separated values or ranges like 23-35.

Example: `db2s_dbmon.pl -i 11, 21, 31-33, 421, 431`

Typically, we collect all data every 30 minutes and only a subset every 10 minutes.

► Note that this data collection poses a noticeable load to your system. If you are not interested in the evaluation of some of the metrics you should adapt the schedule templates accordingly.

In section the troubleshooting section we describe methods how the load can be reduced

### Analysis of the Snapshot Files

The most generic approach is the use of Perl code instead of embedded SQL (ESQL) for the data retrieval, as it can be applied to all database versions. However, the price for it is poor performance.

Snapshots are analyzed in a very generic form, and the different metrics are just configuration items read from a file, `db2s_metrics.cfg`. Each metric listed there defines the scope in the snapshot file where to look for respective data, the set of values that need to be considered and the calculation rule (as Perl code) for the final metric.

► Note: Analyzing a snapshot may be time consuming when processing more than 100 metrics. One standard metric (0933), tablespace free space calculation) requires even a second snapshot to be created for each tablespace when using the Perl approach rather than ESQL.

For this reason, we should not try to collect data more often than required and reasonable, and splitting it into a 10min- and a 30min-cycle time turned out to be useful setting.

In addition, DB2SPI gives a warning in the message browser in case processing for one database exceeds 30 seconds.

There is no such issue (or penalty) when working with ESQL (for DB2 version 8.x), as there is no interpreter in between.

## OVPA / CODA Data Forwarding

Data collected from the snapshots or from the DB2 internal tables are stored temporarily in value files of the DB2SPI itself before these are forwarded to the OV Performance Agent (OVPA) or the embedded collection agent (CODA). Normally, this should be the same resolution as the fastest snapshot collection rate. As default, we have five minutes.

Data that are collected at lower rates than five minutes are transferred with the latest value available from last collection cycle.

This is achieved by another OVO schedule template policy to track correct operation.

## Configuring Alert Thresholds

If snapshot taking and metric calculation is enabled, almost all metrics are sent to the OVO monitoring to check for threshold violations. Please see the DB2SPI Reference Guide for the complete list of metrics that we provide and their threshold values.

In order to change the thresholds, you must modify the respective OVO monitor template and re-distribute the template (policy) to the managed node(s).

We also support a multiplicity of thresholds with the help of "template name spaces", where copies of the policies can be applied with different threshold values, just by adding a prefix. This is described in "Metric Thresholds with Template Name Spaces" on page 65.

Note, that the OVO platform is NOT able to provide local thresholds that would allow different thresholds to be compared to on different nodes or even instances or databases. If there should be a need for specific thresholds, please send an eMail to [spi-support@nice.de](mailto:spi-support@nice.de) and request assistance in doing so.

## Service Management with OVO

Both OVO/Unix and OVO/Windows provide service management capabilities by tracking status changes of services due to messages collected from the managed nodes.

The representation of the services differs significantly.

Service management capabilities of OVO/Unix are offered via the OV Service Navigator. This is an extension to the OVO Java GUI and hence not visible in the Motif GUI. The Service Navigator provides a static, flat view to the service tree.

In OVO/Windows, service display is provided as an integral part. The graphical presentation is a dynamic picture where you can zoom into any area you like.

Both systems, however, act identical on incoming data and can apply the same hierarchic model.



Note that OVO/Windows does not provide a function to remove elements from the service tree, so we cannot do this automatically as in the Service Navigator, e.g., when databases are removed. This must be done manually.

## DB2 Service Hierarchy

In this context DB2 services are defined as the databases monitored by the DB2SPI, and these databases are organized in a four-tier hierarchical manner.

**Table 16: Service Tree Levels**

Level	Meaning	Description
Top Level	DB2	This is the top level hook to access any DB2 service. The icon shown in the service tree is the DB2SPI base icon with the DB2 logo attached.
Level 2	System	This level is linked to the DB2 top level service. Each DB2 server in the managed environment is represented as an icon with the name attached. The icon shown in the service tree is the DB2SPI base icon with a symbolic computer rack in the background.
Level 3	Instance	This level is linked to the DB2 system level service. It consists of all instances on all managed DB2 servers. The icon shown in the service tree is the DB2SPI base icon with a frame containing some database sets in a grey background.
Level 4	Database	This level is linked to the instance level. For each instance, all managed databases are linked to it. The names of these services are just the database names. The icon is the DB2SPI base icon with some symbolic tables on white ground.

Note, that operators can see the DB2 service tree only if they are entitled to. This can be achieved by executing the application `Assign ServiceTree` from the operator's application desktop, and this needs to be done only once.

## DB2 Service Functionality of the DB2SPI

The DB2SPI provides the following functionality to achieve DB2 service management: service discovery, automatic update after configuration changes, enforced update via user application.

### Service Discovery

The DB2SPI automatically determines the service tree on a managed node by analyzing the general configuration file `db2s_instances.cfg` for instances and excluded databases. In addition, DB2 itself is referenced to collect up-to-date information about available databases. This is done automatically every ten minutes on the managed node, but change reports are sent to the management server only if changes have occurred (typically these are new or missing databases etc.).

Initial discovery takes place when the `Config Setup` application has been executed and the DB2SPI templates have been distributed to the managed node and are being started.

### Enforced Service Tree Update

An application, `ServiceTree Update`, is available in the application desktop of the DB2SPI Administrator to allow the user an enforced synchronization between the configuration of the DB2 server and the service tree visualization.

### Status Propagation from Messages to Services

Most events detected by the DB2SPI may affect the service tree, i.e., colorize the icons shown there. Two different levels may be affected by events:

**Instance Level:** Events causing the entire instances to be affected directly map into the instance level of the DB2 service tree.

**Database Level:** Events which are specific for one database map to its respective symbol in the DB2 service tree.



The OVO message severity for the event directly determines the status of the service.

Also, within the DB2 service tree we follow a "most-critical" propagation model; i.e., the most severe status found in the subordinate level determines the color of a service symbol.

Note that any event other than from DB2 or the DB2SPI does not affect the status (and color) of the node level in the DB2 service tree. Its color is solely determined by the underlying DB2 instances and statuses of them.

## OV Reporter Integration

OV Reporter is a powerful tool to create reports about metrics collected on a daily, weekly and monthly basis.

Data acting as the source for reports are found in the OVPA data stores, written when DB2 metrics are calculated.

The location of the reports is [http://<computername>/HPOV\\_Reports/db2spi/](http://<computername>/HPOV_Reports/db2spi/)

Some sample reports can be found in the Appendix B on page 132

# 10 De-installing the DB2SPI

The instructions in this section describe how to remove the DB2SPI software quickly and cleanly from the OVO management server and the managed node. This section covers the following topics:

- Clean-up the Managed Nodes
- Removing the DB2SPI Package
- Removing DB2SPI Components from the OVO GUI

## Clean-up the Managed Nodes

Before cleaning up the central instance you should have removed the DB2SPI components from the managed nodes:

- De-assign the Policies (OVO/Windows)  
This may be done by de-assigning the nodes from the DB2SPI node groups and re-distributing the templates after that.
- Delete the DB2SPI Configuration  
Execute "Config Delete" on all managed nodes to clean-up DB2SPI related files and directories.

### De-Assignment of Policies (OVO/Windows)

To remove the policies from the managed nodes, following these steps:

- 1 Open the Node Configuration Editor on the management server
- 2 Drag all nodes from the DB2 node groups to the root node group "Nodes"
- 3 Close the Node Configuration Editor
- 4 Mark each node and select the function "All Tasks → Redeploy policies and Instrumentation"

Another possible way to remove the policies from the managed nodes is as follows:

- 1 On the management console, right-click the DB2 policy group to be removed (e.g. "DB2SPI Windows").
- 2 Select the function "All Tasks → Uninstall from ..." and choose the node group or node desired (e.g. "DB2 Windows")
- 3 Repeat these steps for all policy groups and DB2 node groups.  
This removes all policies from the nodes that belong to those node groups.
- 4 Remove the managed nodes from the DB2 node groups

Either way you need to execute "Config Delete" for each managed node afterwards.

### A quick Alternative

If you intend to re-install the DB2SPI (same version or an update), you may simply execute the "Config Delete" application without de-assigning the templates / policies. In this case, all DB2SPI templates / policies get disabled automatically without being deleted from the managed node.

After (re-)configuration of the DB2SPI and (re-)deployment of the (possibly refreshed) templates / policies the tool "DB2SPI Enable" may be started to put them back into action.

## Removing the DB2SPI Package from the OVO/Windows Management Server

To remove the DB2SPI and ATOP components from the OVO/Windows management server and complete the general clean-up process:

- 1 On the OVO/Windows management server, enter the Control Panel and select the function "Add/Remove Programs"
- 2 Select the components for removal:
  - DB2SPI

This will remove all installed binaries.

Unfortunately there is no way to eliminate the DB2 elements from the service tree, so this must be done manually, as well as other configuration components.

## Removing DB2SPI Components from the OVO GUI

Unfortunately there is no way to remove configuration elements of the DB2SPI from the OVO/Windows database automatically.

You have to remove the DB2SPI integration with the OVO GUI manually. You will have to remove the following DB2SPI components from the OVO GUI:

- DB2 managed nodes and DB2SPI node groups (Node Configuration Editor)
- DB2SPI tools and tool groups (Tool Configuration Editor)
- DB2SPI policies, policy groups and policies grouped by types
- DB2SPI user profiles (User Roles Configuration Editor)
- DB2 service tree elements (Service Configuration Editor and Service Type Configuration Editor)

# 1 1 Troubleshooting

This section describes how to troubleshoot the DB2SPI. The information provided is designed to help you find, analyze, and fix problems with the DB2SPI quickly and efficiently. In this section, you will find information about:

- Troubleshooting Checklist
- Area: DB2SPI Installation and Components
- Files and Directories
- Area: DB2SPI Usage
- Tracing
- Self-Management of the DB2SPI
- Processes, Services and Scripts

Problems can occur in different areas, and you should first look at the standard scenarios explained in this section before deciding whether or not you need to investigate in more detail.

## Troubleshooting Checklist

This checklist shall assist you in isolating and identifying the problem. Most often it will help to solve the problem yourself, and if not, gives hints what to collect and prepare when calling support for the product.

### **What describes your problem best?**

Problem with installation / de-installation

→ see "Area: DB2SPI Installation and Components"

Problem with the initial configuration

OVO shows an error when running "Config Setup"

→ see "DB2SPI Configuration Issues"

The ATOP window does not open

→ see "Problems with the ATOP Communication Layer"

Problem with the DB2SPI licensing

→ see "License Issues"

No license found (error 33)

License file corrupt (error 34)

Problems in general OVO areas

Problem with unidentified "su" events in the message browser

→ see "Unknown Messages for Switch-User Events"

Deployment problem of instrumentation

→ see "Re-Deployment of "Monitors" cannot be done sometimes"

Problem regarding logfile monitoring

→ see "No Messages from DB2 Log Files"

Problem regarding process monitoring

Missing processes are complained

→ see "DB2SPI Process Monitoring Issues"

Problem regarding metric collection

No messages from metric monitoring at all  
→ see "No Messages from Metric Monitoring"

Messages show up about "incomplete snapshot"  
→ see ""Incomplete Snapshot" Messages appear in the Browser"

A missing "ddflog" is complained  
→ see "Error Reported when Forwarding Data to DDFLOG"

A "missing keyword" is complained  
→ see ""Missing Keyword" Messages appear in the Browser"

OVPA is not installed  
→ see "Message about Missing MeasureWare"

Problem regarding service tree updates  
→ see "Service Tree update does not happen"

Problem regarding the execution of tools  
→ see Symptom 2: "Config Setup" aborts with a "Error 34 (license corrupt)".

### Some data sources

As a first step, make sure that the base installation of OVO is operating correctly. For more information about basic troubleshooting in OVO, see the *HP OpenView Operations Administrator's Reference* (vols 1 & 2)

The DB2SPI provides the following tools, which may be used to find and analyze problems:

**Table 17: Logging and Tracing**

Browser	Messages indicating start / stop problems encountered
Logging	All important steps / events regarding the operation of the DB2SPI itself (configuration, errors encountered etc.) are logged in the a log file on the managed node.
Tracing	Useful information can be collected about each individual step performed during the operation of the DB2SPI. However, tracing must be switched on explicitly.

## Area: DB2SPI Installation and Components

### Installation on OVO/Windows

To verify that the installation of the DB2SPI completed successfully on the OVO management server, carry out the steps described in the following list:

- 1 Open the Windows administrative tool "Add / Remove Programs":  
Look for the following entry: "DB2SPI"
- 2 Check that the elements listed in Table 18 have been added to the OVO GUI.

**Table 18: DB2SPI GUI Components**


**Table 19**

Component Type	Component Name	
Node Groups	DB2-AIX	
	DB2-HPUX	
	DB2-SOLARIS	
	DB2-LINUX	
	DB2-WINDOWS	
Node Groups	DB2-AIX	
	DB2-HPUX	
	DB2-SOLARIS	
	DB2-LINUX	
	DB2-WINDOWS	
Application Groups	DB2 Tools	
	DB2SPI AdminTools	
User Profiles	DB2 Operator Profile	
	DB2SPI Admin Profile	
Template Groups	DB2SPI AIX	DB2SPI Base
		DB2SPI Base (Unix)
	DB2SPI HP-UX	DB2SPI Base
		DB2SPI Base (Unix)
	DB2SPI Linux	DB2SPI Base
		DB2SPI Base (Unix)
	DB2SPI Solaris	DB2SPI Base
		DB2SPI Base (Unix)
	DB2SPI Windows	DB2SPI Base

## Files and Directories

### Installed File Locations on the OVO Management Server

The installation of the DB2SPI software copies the required files to the OVO management server. In addition to the standard locations already available on an OVO management server, the following directories are created.

 Note, that the management server must be a managed node itself.

On HP-UX and Solaris (OVO/Unix):

**Table 20**

/var/opt/OV/atop/log	log and trace files for the communication layer
/opt/OV/atop/bin/	configuration files for the communication layer
/var/opt/OV/db2spi/log	log and trace files
/etc/opt/OV/db2spi/conf	configuration files
/opt/OV/db2spi/bin	script files
/opt/OV/doc/C/db2spi	documentation files

On Windows (OVO/Windows):

**Table 21**

\ProgramFiles\HP-OpenView\Installed Packages\<##>\atop	log and trace files for the communication layer
\ProgramFiles\HP-OpenView\Installed Packages\<##>\db2spi\tmp	temporary storage
\ProgramFiles\HP-OpenView\Installed Packages\<##>\db2spi\log	log and trace files
\ProgramFiles\HP-OpenView\Installed Packages\<##>\db2spi\messages	message files for internationalization (currently unused)
\ProgramFiles\HP-OpenView\Installed Packages\<##>\bin\Instrumentation	templates for configuration files and monitor scripts

### Installed File Locations on the DB2 Servers

Installing and activating the DB2SPI components on the DB2 server (the OVO managed node) establishes the following directories on the OVO managed node.

Note that besides them some files are also kept in the standard "instrumentation" resp. "cmds" and "monitor" directories.

On HP-UX:

**Table 22**

/var/opt/OV/atop/log	log and trace files for the communication layer
/var/opt/OV/OpC/cmds	configuration files for the communication layer
/var/opt/OV/db2spi/tmp	temporary storage
/var/opt/OV/db2spi/log	log and trace files
/var/opt/OV/db2spi/messages	message files for internationalization (currently unused)
/var/opt/OV/db2spi/metrics	metric definition files
/etc/opt/OV/db2spi/conf	configuration files
/var/opt/OV/bin/OpC/monitor	templates for configuration files and monitor scripts (if managed by OVO Server on Unix) (DCE nodes)
/var/opt/OV/bin/instrumentation	templates for configuration files and monitor scripts (if managed by OVO Server on Unix) (HTTPS nodes)
/var/opt/OV/bin/instrumentation	templates for configuration files and monitor scripts (if managed by OVO Server on Windows)

On Solaris:

**Table 23**

/var/opt/OV/atop/log	log and trace files for the communication layer
/var/opt/OV/OpC/cmds	configuration files for the communication layer
/var/opt/OV/db2spi/tmp	temporary storage
/var/opt/OV/db2spi/log	log and trace files
/var/opt/OV/db2spi/messages	message files for internationalization (currently unused)
/var/opt/OV/db2spi/metrics	metric definition files
/etc/opt/OV/db2spi/conf	configuration files
/var/opt/OV/bin/OpC/monitor	templates for configuration files and monitor scripts (if managed by OVO Server on Unix) (DCE nodes)
/var/opt/OV/bin/instrumentation	templates for configuration files and monitor scripts (if managed by OVO Server on Unix) (HTTPS nodes)
/var/opt/OV/bin/instrumentation	templates for configuration files and monitor scripts (if managed by OVO Server on Windows)



**Table 24 Directories on AIX**

/var/lpp/OV/atop/log	log and trace files for the communication layer
/var/lpp/OV/instrumentation	configuration files for the communication layer
/var/lpp/OV/db2spi/tmp	temporary storage
/var/lpp/OV/db2spi/log	log and trace files
/var/lpp/OV/db2spi/messages	message files for internationalization (currently unused)
/var/lpp/OV/db2spi/metrics	metric definition files
/etc/opt/OV/db2spi/conf	configuration files
/var/lpp/OV/bin/OpC/monitor	templates for configuration files and monitor scripts (if managed by OVO Server on Unix)
/var/lpp/OV/bin/instrumentation	templates for configuration files and monitor scripts (if managed by OVO Server on Windows)

**Table 25 Directories in Linux**

/var/opt/OV/atop/log	log and trace files for the communication layer
/var/opt/OV/OpC/cmds	configuration files for the communication layer
/var/opt/OV/db2spi/tmp	temporary storage
/var/opt/OV/db2spi/log	log and trace files
/var/opt/OV/db2spi/messages	message files for internationalization (currently unused)
/var/opt/OV/db2spi/metrics	metric definition files
/etc/opt/OV/db2spi/conf	configuration files
/var/opt/OV/bin/OpC/monitor	templates for configuration files and monitor scripts (if managed by OVO Server on Unix)
/var/opt/OV/bin/instrumentation	templates for configuration files and monitor scripts (if managed by OVO Server on Windows)

**Table 26 Directories in Windows (DCE Managed Nodes) Managed by OVOU**

<code>\usr\OV\atop\log</code>	log and trace files for the communication layer
<code>\usr\OV\atop\conf</code>	configuration files for the communication layer
<code>\usr\OV\db2spi\tmp</code>	temporary storage
<code>\usr\OV\db2spi\log</code>	log and trace files
<code>\usr\OV\db2spi\messages</code>	message files for internationalization (currently unused)
<code>\usr\OV\db2spi\metrics</code>	metric definition files (not supported yet)
<code>\usr\OV\db2spi\conf</code>	node specific configuration files
<code>\usr\OV\bin\OpC\monitor</code>	configuration files and monitor scripts (DCE nodes)


**Table 27: https on Windows (managed by OVO Server on UNIX)**

<code>...\data\atop\log</code>	log and trace files for the communication layer
<code>...\data\bin\instrumentation</code>	configuration files for the communication layer
<code>...\data\db2spi\tmp</code>	temporary storage
<code>...\data\db2spi\log</code>	log and trace files
<code>...\data\db2spi\messages</code>	message files for internationalization (currently unused)
<code>...\data\db2spi\metrics</code>	metric definition files (not supported yet)
<code>...\data\db2spi\conf</code>	node specific configuration files
<code>...\data\bin\instrumentation</code>	configuration files and monitor scripts

**Table 28 On Windows (managed by OVO Server on Windows)**

<code>\ProgramFiles\HP-OpenView\InstalledPackages\&lt;##&gt;\atop\log</code>	log and trace files for the communication layer
<code>\ProgramFiles\HP-OpenView\InstalledPackages\&lt;##&gt;\atop\conf</code>	configuration files for the communication layer
<code>\ProgramFiles\HP-OpenView\InstalledPackages\&lt;##&gt;\db2spi\tmp</code>	temporary storage
<code>\ProgramFiles\HP-OpenView\InstalledPackages\&lt;##&gt;\db2spi\log</code>	log and trace files
<code>\ProgramFiles\HP-OpenView\InstalledPackages\&lt;##&gt;\db2spi\conf</code>	configuration files
<code>\ProgramFiles\HP-OpenView\InstalledPackages\&lt;##&gt;\db2spi\messages</code>	message files for internationalization (currently unused)
<code>\ProgramFiles\HP-OpenView\InstalledPackages\&lt;##&gt;\bin\Instrumentation</code>	templates for configuration files and monitor scripts

## Configuration Files

 Note: All directory information given next is given for HP-UX managed nodes to preserve readability. For other platforms, these directories must be replaced logically by the names given in "Installed File Locations on the DB2 Servers".

### ATOP Communication Layer

On the management server there is the central configuration file

OVO/Unix:

`/opt/OV/atop/bin/atopsrv.cfg`

OVO/Windows:

`\Program Files\HP OpenView\bin\DB2SPI\atopsrv.cfg`

This should act as the primary source for all modifications.


For distribution to the managed nodes, equivalent files `atop.cfg` are kept in all supported platform-specific directories for the managed nodes, hence

/var/opt/OV/share/databases/OpC/mgd\_node/customer/<...>/cmds

on the management server. After distributing the actions / commands / monitors a copy is kept in the cmds directory on the managed node.

On Microsoft Windows based OVO Java display stations, the file can be found in

\Program Files\Hewlett-Packard\Nice\ATOP

 Note: Whenever changes need to be made to the ATOP configuration file, especially regarding the port information, this must be re-distributed to the managed nodes and to the Java GUI stations or OVO/Windows management consoles.


### General DB2SPI Configuration Files

There is one general DB2SPI configuration file which is installed and used on the management server as well as on the managed nodes.

Distributing the DB2SPI instrumentation to the managed node copies this configuration file to the monitor directory resp. instrumentation directory.

The file contains the default settings of the DB2SPI configuration:

db2s\_spi.cfg      Default configuration file for DB2SPI operation

 Note, that this file is overwritten every time you enforce a new distribution of the DB2SPI monitors from the management server.

After executing Config Setup, the following files are created in the configuration file directory .../db2spi/conf on the managed node:

db2s\_spi.cfg      Active image of the default configuration file db2s\_spi.cfg; this copy may be modified to change the default behavior of the DB2SPI on the managed node, like enabling / disabling performance monitoring or switching trace options.

db2s\_instances.cfg      This file contains information about the DB2 version and edition present on the managed node and the instances that have been configured during Config Setup. This file is encrypted.

db2s\_replicpaths.cfg      When SQL replication logfile monitoring is set up this file is created in the configuration file directory. It contains the paths of the SQL replication logfiles. The capture log file paths are extracted from the CAPTURE\_PATHS column in the <your\_schema>.IBMSNAP\_CAPPARMS table. The apply logfile paths for each apply qualifier are obtained from the APPLY\_PATHS column in the ASN.IBMSNAP\_APPPARMS. If these values are not set, please ask you DBA to specify the paths with the help of the Replication Center in the corresponding tables.

## DB2SPI Runtime License File

In the monitor (or instrumentation) directory we also keep the DB2SPI runtime license file, `db2s_license.dat`. This file contains all runtime licenses in encrypted form the user has obtained. It is read by the DB2SPI and should not be modified at any time to preserve DB2SPI operation.

If this file should be deleted or get corrupted, simply re-deploy "monitors" (OVO/Unix) or "instrumentation" (OVO/Windows) for a reset.



Note: With the "License Check" tool you can verify the validity of the runtime licenses on each managed node.

## Self-Healing Services Configuration Files

### Installation Description File

The installation description file `db2s_install.xml` contains all data about the (deployed) version of the DB2SPI on the managed node.

This file is used by the HP OpenView Self-Healing Client to find out the products installed on a managed node.

It is located in the monitor resp. instrumentation directory on the managed node.

### SHS Collector Information File

The SHS collector information file `db2s_shscollin.xml` is an XML file which specifies the data to be collected. The data is grouped into "contexts". The context is a label that is used to specify what data is to be collected.

It is located in the monitor resp. instrumentation directory on the managed node.

### Registration Files

There are two registration files, one for Windows nodes and one for UNIX nodes. In the registration file, the "source-name" attribute is the "source name" component of the SPI's application identifier (see section "Implementation details") and the "name" attribute is the "source description" component of the application identifier.

These files are named `db2s_shsreg_unix.xml` and `db2s_shsreg_win.xml` and can be found in the monitor resp. instrumentation directory on the managed node.

## Other Configuration Files

Many functions of the DB2SPI are written in a very generic way, and their effective action is determined via configuration files. All these files are also kept in the monitor (or instrumentation) directory of the managed nodes. Their common identifiers are:

- 1 a prefix "db2s\_"
- 2 a postfix ".cfg"

These files must not be modified by the user to assure proper operation of the DB2SPI.

If any file should be deleted or get corrupted, simply re-deploy "monitors" (OVO/Unix) or "instrumentation" (OVO/Windows) for a reset.

## Log Files

### ATOP Log Files

The ATOP log file lists extraordinary states and problems that are encountered when the ATOP communication layer executes. ATOP log files can be found on all systems the run components of the ATOP subsystem, i.e., the management server, the managed nodes and the Java GUI display stations.

- 1 On the management server (running the ATOP server as an OV service):

```
/var/opt/OV/atop/log/atop_serversrv.log
```

- 2 On the managed node (running the ATOP client to connect to applications):

```
/var/opt/OV/atop/log/atop_server.log
```

- 3 On Windows based Java GUI display stations (running the ATOP server as a service):

```
\Program Files\Hewlett-Packard\NiCE\ATOP\Logs\atop_server.log
```

### DB2SPI Log File

All important internal states and messages are written to a log file on the managed node, `.../db2spi/log/db2spi.log`. All configuration events as well as important events during operation are logged to this file.

Many of the entries are monitored by the DB2SPI itself, using a proper template (policy), but this does not filter all events from it nor does it provide accurate timing and sequencing in the OVO message browser.

For details and the complete history you should therefore check this log file directly.

Details about errors and problems logged in this log files can be found later in this manual

## Metric Storage on Unix Managed Nodes

Metric data are stored in series of files in the metrics directory as listed above.

Please make sure that these files are not modified or deleted in order to guarantee proper operation of the DB2SPI.

## DB2SPI Service Tree Configuration

There is one configuration file that keeps the former state of the monitored DB2 services, `.../db2spi/conf/db2s_svctree_conf.keep`. This file is used to determine the need of updating the service tree on the management server, which is otherwise skipped if no changes have occurred in the managed objects.

This file is referenced and possibly updated whenever the DB2SPI service discovery runs, instance configuration or database filtering is executed or when the user requests an update of the service tree.

## Area: DB2SPI Usage

This section describes the troubleshooting scenarios that you are likely to encounter when using the DB2SPI. Each problem is described in terms of possible symptoms and a likely cause, which is designed to help you pinpoint the problem and solve it as quickly and efficiently as possible.

## Common Areas and Symptoms

### Installation on OVO/Unix

To verify that the installation of the DB2SPI completed successfully on the OVO management server, carry out the steps described in the following list:

On the command line, enter: **swlist** and look for the following entry:

```
DB2SPI      A.03.00      DB2 SMART Plug-In for HP OVO
```

Check the following log files for more specific information relating to installation problems:

- /var/adm/sw/swagent.log
- /var/adm/sw/swinstall.log

Check that the OVO configuration elements are all available in the OVO Administrator GUI. If not, you can check the file `opccfgupld.log` or `opccfgupld.old` for possible problems during upload. Note, that these files are overwritten by subsequent configuration uploads.

### DB2SPI Configuration Issues

Please also see the sections "License Issues" and "Problems with the ATOP Communication Layer" for possible scenarios

Symptom 1: In the window of the `Config Setup` application an error message (OpC30-913) is shown for `opcmsg`, adjacent with the text:

```
"This is a warning only since there is no opcmsg
template yet.
```

```
Completion of DB2SPI installation will provide
one."
```

Possible Cause: There is no `opcmsg` template on the managed node that could intercept the message generated by the `Config Instance` application. This problem is not critical: when installing the DB2SPI later, the appropriate `opcmsg` template will be installed automatically.

Action: None required.

### License Issues

Symptom 1: "Config Setup" aborts with a "Error 33 (no valid license)".

Applications cannot be started.

Messages in the message browser contain the string "Error 33 (no valid license)".

Possible Cause: The DB2SPI license might have expired (common at the end of the evaluation period) or not installed at all.

Action: The DB2SPI Administrator may check the globally available valid licenses with the "License List" tool. He should rerun the "License Add" tool to provide a valid license and distribute the "monitors" ("DB2SPI instrumentation" on OVO/Windows) to the managed nodes again.

Symptom 2: "Config Setup" aborts with a "Error 34 (license corrupt)".

Applications cannot be started.

Messages in the message browser contain the string "Error 34 (license corrupt)".

Possible Cause: Either the file `db2s_license.dat` got damaged on the managed node (case a), or, with the "License Add" tool, an invalid license string has been added (case b), for

example an "HP SPI Installation License Key" rather than a "NiCE DB2SPI Runtime License Key".

Action: Case a: Re-deploy the instrumentation from the management server.  
Case b: Delete all occurrences of the db2s\_license.dat file on the management server (from all platform directories!) and re-run "License Add". Be sure to add only the license key file(s) supplied by NiCE. See "Appendix C: DB2SPI Licensing" on page 141 for details.

### DB2SPI Application Execution Issues

Symptom 1: You cannot start DB2SPI application for a given instance even though the DB2 instance is displayed in the instance-selection menu

Possible Cause: If you misspell the name of the DB2SPI Administrator during "Config Setup" or enter the name of an instance user that does not exist, the configuration file generated by the Config Setup application is unusable for one or all instances and, as a consequence, no operation is executed.

Action: A DB2SPI Administrator should drop this faulty configuration with "Config Delete" and then rerun the "Config Setup" application and enter the correct values for the DB2 Administration Server and instance users.

### DB2SPI Process Monitoring Issues

Symptom 2: Applications cannot be started.  
Messages in the message browser show "Error 33 (no valid license)".

Possible Cause: The DB2SPI license might have expired (common at the end of the evaluation period)

Action: The DB2 Administrator should rerun the Add Licenses to provide a valid license and distribute the "monitors" ("DB2SPI instrumentation" on OVO/Windows) to the managed nodes again.

Symptom 3: Many messages appear from process monitoring that are obviously wrong.

Possible Cause: DB2SPI relies on the DB2 edition specification given by the user. Maybe this was not given correctly or the database has been upgraded / reconfigured later on.

Action: Reconfigure the DB2SPI with "Config Setup".

Symptom 4: In the window of the Config Setup application an error message (OpC30-913) is shown for opcmsg, adjacent with the text:  
"This is a warning only since there is no opcmsg template yet.  
Completion of DB2SPI installation will provide one."

Possible Cause: There is no opcmsg template on the managed node that could intercept the message generated by the Config Instance application. This problem is not critical: when installing the DB2SPI later, the appropriate opcmsg template will be installed automatically.

Action: None required.

### No Messages from DB2 Log Files

Symptom: New entries in the DB2 notification log do not generate messages and, as a consequence, no messages appear in the Message Browser window.



- Possible Cause: The DB2 database instance specific log file may have been moved after the DB2SPI has been configured
- Action: Either provide a link at the old place or adapt the log file configuration file in the DB2SPI configuration directory manually.

### Unknown Messages for Switch-User Events

- Symptom: Many messages with "unknown" severity appear in the Message Browser window
- Possible Cause: If you have configured the standard `syslog` template for HP-UX, or `su_log` (AIX) on the managed node, each time a DB2SPI process monitoring is to be executed an "su" is performed and logged to the `syslog` log file. The "su" event is trapped but does not have a severity assigned in the standard template.
- Action: Improve the `syslog` template to suppress these messages as explained here:
- For HP-UX, add one or more suppress conditions to the `syslog` (HP-UX) template with text patterns like:
- ```
su : + <*> root-<InstanceUserName>
```
- For AIX, add a suppress condition to the `su_log` (AIX) template with a text pattern like:
- ```
SU <*> + <*> root-<InstanceUserName>
```
- Note that you need a match for each name an instance user has been set up with on the DB2 servers and their instances to be managed. We recommend you use generic names such as `db2inst<n>` in order to simplify management.

### Message about Missing MeasureWare

- Symptom 1: The following message appears from time to time in the Message Browser window:
- ```
"MWA not installed on <Hostname>. Disabling metric recording"
```
- Possible Cause: The MeasureWare agent (OVPA) is not running on the managed node, but you have configured (standard) performance monitoring with the DB2SPI, which cannot find the OVPA agent.
- Action: Either install OVPA on the managed node or disable forwarding of performance data by running the appropriate "PerfRep Disable" application from the DB2SPI Admin application group.

### Re-Deployment of "Monitors" cannot be done sometimes

- Symptom 1: The OVO Administrator receives an error during "forced" policy deployment like
- ```
Errors occurred during distribution of the monitors.  
Solve the problem and distribute the monitors again  
(OpC30-1030)  
  
Can't delete file  
/var/opt/OV/bin/OpC/monitor.old/db2s_dallilib.sl OpC30-  
1003)
```
- Possible Cause: The internal DB2SPI library is currently in use (probably by `db2s_dbmon.pl`), which prevents the replacement by OVO.
- Action: Either re-try after a while or temporarily disable the DB2SPI by running the application "DB2SPI Disable" on the OVO managed node in question; don't forget to re-enable it later on..

### No Messages from Metric Monitoring

- Symptom 1: Performance messages do not appear in the Message Browser window
- Possible Cause: If you successfully distributed the DB2SPI templates, the performance monitoring scripts are operating, but may be suffering from a lack of data. DB2 provides performance data only if the collection of performance data is enabled.
- Action: Run the application "Snapshot Enable" on the OVO managed node in question to make sure that the database server has enabled data collection.

### "Incomplete Snapshot" Messages appear in the Browser

- Symptom 1: Messages like Incomplete snapshot for <database> appear in the message browser window
- Possible Cause: This indicates that the DB2 instance is not configured to collect all performance metrics that we request.
- Action: Run the application "Snapshot Enable" for the instance in question to make sure that the database server has enabled data collection. For more information, see "Enable / Disable DB2 Snapshots" on page 63.

### "Missing Keyword" Messages appear in the Browser

- Symptom 1: Messages complaining about missing keywords in the DB2 snapshots appear in the message browser window
- Possible Cause: This may happen if DB2 does not provide values for all metrics we are looking for. A typical case is the FCM area: If this is not available, but the metrics 0890, 0900, 0910, 0920 are requested from the metric schedule template db2s\_metrics\_10m, such messages will appear.
- Action: Create a snapshot with the "Show Snapshot" application and check for the areas covered by DB2. Disable (remove) the respective metrics from the schedule template.

### Error Reported when Forwarding Data to DDFLOG

- Symptom 1: During data collection an error is reported with "ddflog" keyword.
- Possible Cause: The DDFLOG tool may not be installed on the managed node. While this is hardly possible in OVO/Unix environments, it may easily be forgotten from the OVO/Windows console.
- Action; Just deploy the "DSI2DDF" area in the instrumentation deployment on the OVO/Windows console for the managed node(s) affected.
- Possible cause: OVPA data files may have been deleted or corrupted.
- Action: Unfortunately we cannot recover from lost or corrupted data. The only option is to re-configure the DB2SPI (run "Config Delete" and "Config Setup" in sequence).

### Service Tree update does not happen

- Symptom 1: There is no update in the service tree although DB2 or DB2SPI configuration has been changed
- Possible Cause: The schedule template for service discovery, db2s\_discover\_svctree, is not enabled / active or the log files templates db2s\_svctree\_auto and db2s\_svctree do not work.
- Action: Run the application "ServiceTree Update" on the OVO managed node in question to make sure that all configuration files and DB2 itself are checked.

Symptom 2:	Messages with "svctree" in the application attribute and names of databases in the message text are appearing in the Message Browser window and do not disappear automatically.
Possible Cause:	Normally, an automatic action is performed on the management server to process the service tree configuration changes transmitted from the managed nodes. If they do not get processed, the automatic action (script db2s_make_svctree.pl) cannot be executed on the management server or the service engine might not respond.
Action:	Make sure that the management server is a managed node. Check that the service engine is running.

## Problems with the ATOP Communication Layer

### Application Windows do not pop up

**Table 29: Atop Troubleshooting**

Symptom 1:	When running a DB2SPI application, no window appears at all although OVO does not report a problem.
Possible Cause:	There are many reasons for this! Please see the "Action" part below for possible checks.
Action:	<p>Make sure that the ATOP server is installed and running on your management server and, if working with the Java GUI, on that display station.</p> <p>On the OVO/Unix management server, run "ovstatus atop_server" and on OVO/Windows check the "ATOP server service" in the "Services" window of the control panel.</p> <p>The latter must also be available on the Java GUI station.</p> <p>There could be problems with the network connection (ports are blocked at firewalls, ATOP port could be used by any other program). Check the respective configuration(s)</p> <ol style="list-style-type: none"> <li>Problems when starting the application interface could arise due to resource problems on the managed node. Check system load.</li> </ol> <p>The same holds for the ATOP server node – on UNIX there is little risk, but on Windows we need JRE as well. Check system load.</p> <ol style="list-style-type: none"> <li>Verify that the same ports are defined on both the managed node and the management server (resp. Java GUI stations) for the communication; check the ATOP configuration files for this.</li> </ol>

## Tracing

This section describes how you can use the tracing feature incorporated in the DB2SPI to help you in your troubleshooting. The information written to the trace files is designed to help you pinpoint and solve problems as quickly and efficiently as possible. This section covers the following troubleshooting areas:

- Trace Configuration Location
- Configuring the Trace Area
- Extending Trace Information

- Activating DB2SPI Tracing
- DB2SPI Trace Files



Note: Tracing can produce large amounts of data in the trace file, and there is no file-size limitation for this logging. You should therefore use tracing only when necessary and, in addition, make sure that tracing is switched off after you have successfully solved the problems you are using tracing to investigate.

## Trace Configuration Location

The DB2SPI can be traced independently from OVO by using its separate, DB2SPI-specific, configuration file, `db2s_spi.cfg`, which contains the appropriate settings for DB2SPI-specific tracing.

The default configuration file, `db2s_spi.cfg`, is transferred during the initial distribution of DB2SPI monitors from the OVO management server to the OVO managed nodes (DB2 servers). During instance configuration with the "Config Setup" application the configuration file is placed in the following directory on the OVO managed node (given for all Unix systems here):

```
/etc/opt/OV/db2spi/conf
```

The following listing shows the default contents of the configuration file, `db2s_spi.cfg`.

Besides some other flags and settings that are usually affected and modified by proper tools in the DB2SPI Admin application group, there are also three entries that determine the trace behavior.

### Example 1: Default DB2SPI -Configuration File (trace section only)

```
#####
#
# File:          db2s_spi.cfg
# Description:   The general configuration file of DB2SPI.
# Package:      HP OpenView SMART Plug-In for DB2
#
# (c) NiCE GmbH 2001-2003
#####

#          DB2SPI_TRACE_STATUS:
#          Status of DB2SPI Tracing on Managed Node
#          Values:  ON    Tracing enabled
#                  OFF   Tracing disabled (default)
DB2SPI_TRACE_STATUS OFF

#-----

#          DB2SPI_TRACE_AREA:
#          Give program names to be traced,
#          e.g. db2s_showsnap.pl
```

```

#           Values:  ALL    Trace all programs
#
#           <name> name of program to be traced
#
#           default is: no program
#
#           If more than one program is to be traced,
#           add one line for each program
DB2SPI_TRACE_AREA db2s_db2spi.pl
#-----

#           DB2SPI_TRACE_PLUS:
#           Trace addition area (extra information)
#           >  WARNING
#           >  -----
#           >  This can produce an EXCESSIVE amount
#           >  of data; use it only when requested
#           Values:  OFF    Add nothing (default)
#
#                   ENV    Add environment settings
#                   DIAGLOG Add diagnostic log records
#                   METRICS Add metric value records
#                   SNAP   Add snapshot data
DB2SPI_TRACE_PLUS OFF

```

---

## Configuring the Trace Area

You can specify which programs you want to trace by setting the `DB2SPI_TRACE_AREA` variable in the `db2s_spi.cfg` file and using the appropriate program, name as the value. For example:

```
DB2SPI_TRACE_AREA <program_name>
```

If you want to trace all programs, use the value "ALL" as the parameter value.

However, it is not recommended to trace the entire DB2SPI as many processes are executing and will fill up your disk rapidly. Use the "ALL" mode only if requested by the DB2SPI support.

## Extending Trace Information

Sometimes it may be helpful to extend the amount of trace information in order to see environmental data, previous metric values, original logfile entries etc. in context of the DB2SPI processing. This is the purpose of the `DB2SPI_TRACE_PLUS` switch.

Depending on the area given there, a lot of additional data can be collected and put into the DB2SPI trace file.

This function should only be used if requested by the DB2SPI support.

If activated once, it should be disabled as soon as possible because it produces very large trace logs.

## Activating DB2SPI Tracing

### Changing the Configuration File manually

You can activate (or de-activate) tracing in the DB2SPI by setting the `DB2SPI_TRACE_STATUS` variable in the configuration file, `db2s_spi.cfg`, to either "ON" or "OFF", respectively. For example, to activate DB2SPI tracing, set the following variable as indicated:

```
DB2SPI_TRACE_STATUS ON
```

Tracing starts automatically after the DB2SPI writes the "ON" flag back to disk; there is no need to restart any processes. In order to de-activate tracing, reset the `DB2SPI_TRACE_STATUS` parameter to "OFF". Tracing stops automatically after the DB2SPI writes the "OFF" flag back to disk. You do not need to restart any processes.

### Changing the Trace Status via Desktop Application

In the application desktop of the DB2SPI Admin application group there are two functions that allow you to do the change of the `DB2SPI_TRACE_STATUS` field programmatically.

With `Trace Enable` you set this field to the status ON

With `Trace Disable` you set this field to the status OFF

Note, that the area to be traced is not affected by this switch; this must still be set manually as described above.

## DB2SPI Trace Files

DB2SPI trace data are written to the following file in the DB2SPI log directory:

```
.../db2spi/log/db2s_trace.log
```

Note, that no file-size limitations exist for the `db2s_trace.log` file while tracing is enabled.

Traces are generated in a two-step approach:

For each process / script that is given in a `DB2SPI_TRACE_AREA` command in the configuration file, a separate trace file named `db2s_trace.log.<pname>.<pid>` is created where all traces are stored. When the process / script ends regularly, this file is appended to the general trace file `db2s_trace.log`. These interim trace files are kept in a temporary directory of the DB2SPI, `/var/opt/OV/db2spi/tmp`. If the process / script should abort before, the separate trace file is preserved there.



It is good practice to check the temporary directory from time to time for remainders of such trace operations.

## Self-Management of the DB2SPI


The DB2SPI is configured to monitor its own status and notifies the user of any changes in status, problems, and errors etc. as follows:

- The DB2SPI self-management feature generates messages for all internal state changes and any problems and sends the messages to the DB2SPI administrator.
- Most of the messages generated by the DB2SPI contain instruction text, which offers a potential explanation as to why the message was generated.

This self-management is primarily achieved via the DB2SPI log file described earlier and an OVO log file template, `DB2SPI_ownlog1`, which is contained in the `DB2SPI Base` template group and hence get distributed to all managed nodes, which are hosting a DB2 management.

## Processes, Services and Scripts

A number of scripts and processes are installed and run on the managed nodes during the installation and deployment of the DB2SPI. The following lists give a brief explanation of the various files:

 Note: The operator never needs to start any of the scripts in the following list directly: these scripts are activated by DB2SPI applications or monitors.

**Table 30: Scripts on the managed nodes**

Script Name	Description
<code>atop (atop.exe)</code>	ATOP client to process DB2SPI applications
<code>db2s_flexapp.pl</code>	runs the flexible tools
<code>db2s_asciirep.pl</code>	creates ASCII reports (interactively or as automatic actions)
<code>db2s_chgadmin.pl</code>	Changes the user name of the DB2 administrator user
<code>db2s_db2spi.pl</code>	enable / disable the DB2SPI
<code>db2s_dbfilter.pl</code>	switches the monitoring of individual databases
<code>db2s_fulltrace.pl</code>	tool to switch tracing on and off
<code>db2s_genlib.pl</code>	library holding general functions of the DB2SPI. Required by all other scripts
<code>db2s_ilst.pl</code>	list all instances and databases defined / managed on the DB2 server
<code>db2s_instlib.pl</code>	library holding functions for DB2 instance management. Required by all scripts accessing DB2
<code>db2s_mwafwd.pl</code>	tool to enable / disable forwarding of performance data to the MeasureWare or CODA agent
<code>db2s_opcfwd.pl</code>	tool to enable / disable forwarding of performance data to the OVO monitor agent
<code>db2s_perflib.pl</code>	library holding functions for metric data processing
<code>db2s_prep_svctree.pl</code>	tool to analyze and process instances and databases for OV Service Navigator
<code>db2s_pvselect.pl</code>	script to process predefined graphing requests
<code>db2s_setupinst.pl</code>	define the instances to be managed on the DB2 server
<code>db2s_showbcfg.pl</code>	tool to display the database configuration

<b>Script Name</b>	<b>Description</b>
db2s_showmgrcfg.pl	tool to display the database manager configuration
db2s_showsnap.pl	tool to display a performance snapshot in a window
db2s_snap_switch.pl	enable/disable DB2 performance data collection
db2s_istart.pl	start / stop a selected DB2 instance
db2s_udmchk.pl	check UDM definition
db2s_xmllib.pl	library holding generic functions of the XML parser
db2s_dbmon.pl	executes the entire performance data collection
db2s_diag.pl	pre-process the administration log files
db2s_fsize.pl	process file size monitoring of various log files
db2s_list_conf.pl	configuration listing (OVO/Windows only)
db2s_mwalog.pl	forward the intermediate performance data collected to OVPA
db2s_platfpath.pl	determine path of files depending on the platform
db2s_ruleprocmon.pl	performs process monitoring
db2s_Balanced.pm	component for XML parsing and processing
db2s_RecDescent.pm	component for XML parsing and processing
db2s_dallilib.pm	Perl interface to C library
db2s_dallilib.so	C library with DB2 access functions and others
db2s_licrep.pl	license reporting
db2s_start	starts all our scripts in well-defined environment
db2s_startcoll	prepares the environment for metric collection
db2s_metcoll	binary program for metric collection
db2s_sudo	switches between users in non-root environments
db2s_root.pl	one-time utility for setup in non-root environments
db2s_list_conf.pl	obtain DB2SPI policy list (OVOW only)
db2s_metrmon.pl	enable / disable metric monitoring
db2s_replic_status.pl	show status of DB2 replication
db2s_replicdiag.pl	analyze the replication log files
db2s_rundb2.pl	start the DB2 command line processor

**Table 31: On the Management Server, the following scripts are installed**

<b>Script Name</b>	<b>Description</b>
db2s_genlib.pl	library holding general functions of the DB2SPI. Required by all other scripts



<b>Script Name</b>	<b>Description</b>
db2s_helptext.pl	searches and returns the instruction text from the instructions reference file
db2s_make_svctree.pl	tool to prepare the XML file for the OV Service Navigator resp. OVO/Windows
db2s_nicelice.pl	install or add new DB2SPI licenses
db2s_pvpredef.pl	start PerfView to display predefined graphs
db2s_udmcfg.pl	script to configure user defined metrics (UDM)
db2s_xmllib.pl	library holding generic functions of the XML parser
db2s_Balanced.pm	component for XML parsing and processing
db2s_RecDescent.pm	component for XML parsing and processing
db2s_dallilib.pm	Perl interface to C library
db2s_dallilib.so	C library with DB2 access functions and others
db2s_licrep.pl	license reporting
db2s_start	starts all our scripts in well-defined environment

## ATOP Services

On Java display stations, the "ATOP2 server" service is installed automatically when downloading the ATOP Java GUI from the management server.

It can be checked with normal Windows means in the "Services" window.

On the OVO management server, the "atop\_server" is set up during installation of the package.

It can be checked with the ovstatus command.

# 12 Appendix A: DB2 Processes Monitored

The following tables show the different processes that are checked by the DB2SPI.

## DB2 UDB Processes monitored in Unix Systems

V 8.x means DB2 V 8.1 as well as DB2 V 8.2 unless notes otherwise. See Notes below.

	V 8.x E Enterprise Edition	V 8.x ESE prim	V 8.x ESE sec
db2fmcd	X	X	X
db2fmd 4)	X	X	X
dasrrm (1)	X	X	X
db2wdog (5)	X	X	X
db2sysc	X	X	X
db2gds (2)	X	X	X
db2resync	X	X	X
db2srvlst	X	X	X
db2tcpem		X	X
db2ipccm	X	X	X
db2ckpwd	3 X	3 X	3 X
db2pdbc		X	X
db2panic		X	X
db2fcmdm (3)		X	X

X	Process runs as instance
X	Process runs as admin
X	Process runs as root
X	Process runs as system

Notes:

- (1) dasrrm on AIX and Linux not checked except for ESE environments
- (2) db2gds runs as root on Solaris
- (3) db2fcmdm on AIX and Solaris not checked in DB2 V8.2 ESE sec
- (4) db2fmd not checked on Linux
- (5) db2wdog not checked on Linux

## Processes monitored in Windows Systems

V 8.x means DB2 V 8.1 as well as DB2 V8.2 unless noted otherwise.

	V 8.x Enterprise Edition	V 8.x ESE Single	V 8.x ESE prim	V 8.x ESE sec
db2syscs	1 per system	1 per system	<b>2 per system</b>	-
db2jds	1 per system	1 per system	1 per system	1 per system
db2rcmd	1 per system	1 per system	1 per system	1 per system
db2sec	1 per system	1 per system	1 per system	1 per system
db2dasrrm	1 per system	1 per system	1 per system	1 per system

# 13 Appendix B: OV Reporter Templates Integration

## Installing DB2SPI Reports for OV Reporter

The DB2SPI software contains predefined OV Reporter templates to prepare reports about some performance data collected via MeasureWare.



Note: This applies only to the integration into the OV Reporter. The reporting component of OVO/Windows is not able to connect to the data store we fill with the DB2SPI and therefore cannot be used for DB2SPI reporting-

### Prerequisites

The installation of DB2SPI Reports expects the following installations and settings have been done on the OV Reporter hosting system before starting the setup:

- OV Reporter Version 3.6 is installed

When integrating with OVO/Unix, the following also applies:

- Oracle client and Oracle driver are installed for communication with the OVO/Unix database (used partly in DB2SPI reports when looking for DB2 related messages in the OVO database)
- An ODBC interface (ov\_net) is established to the OVO/Unix management server
- The "OV/Operations 7&8 Reports" are loaded (check within OV Reporter in the "File → Configure → Report Packages" window)

### Reports Installation

The installation is simply execution of an InstallShield package on the system hosting the OV Reporter. The package is contained separately on the DB2SPI CD-ROM.

The individual steps are as follows:

- 1 On the Windows system with the OV Reporter installed insert the DB2SPI CD-ROM.
- 2 From the CD-ROM, install it using InstallShield with the package DB2SPI-Reporter.msi.

When starting the installation, a window pops up with the DB2SPI logo:

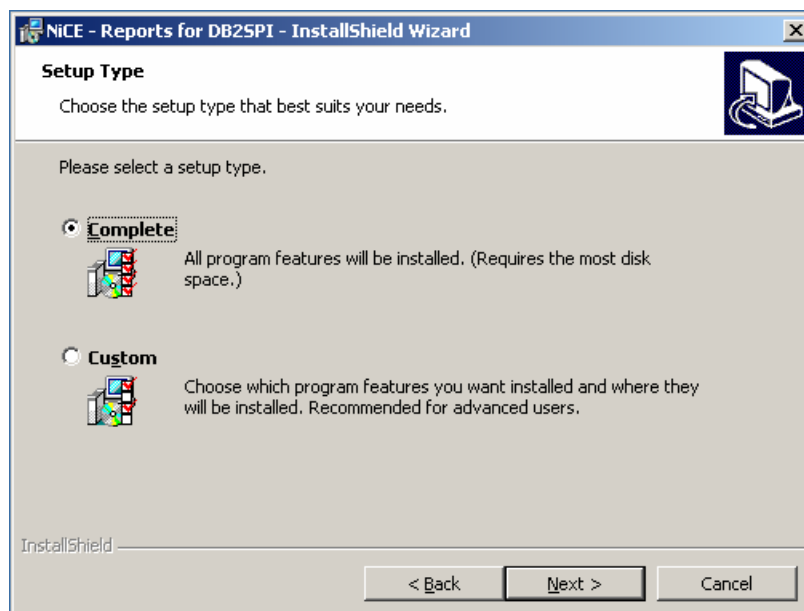
Figure 31: DB2SPI Service reports installation start



No other steps are required. The package automatically plugs into the OV Reporter.

It is recommended to select "Complete" installation when asked for. "Custom" installation should only be done in special customer situations and will not be explained here.

Figure 32: Service reports installation type window



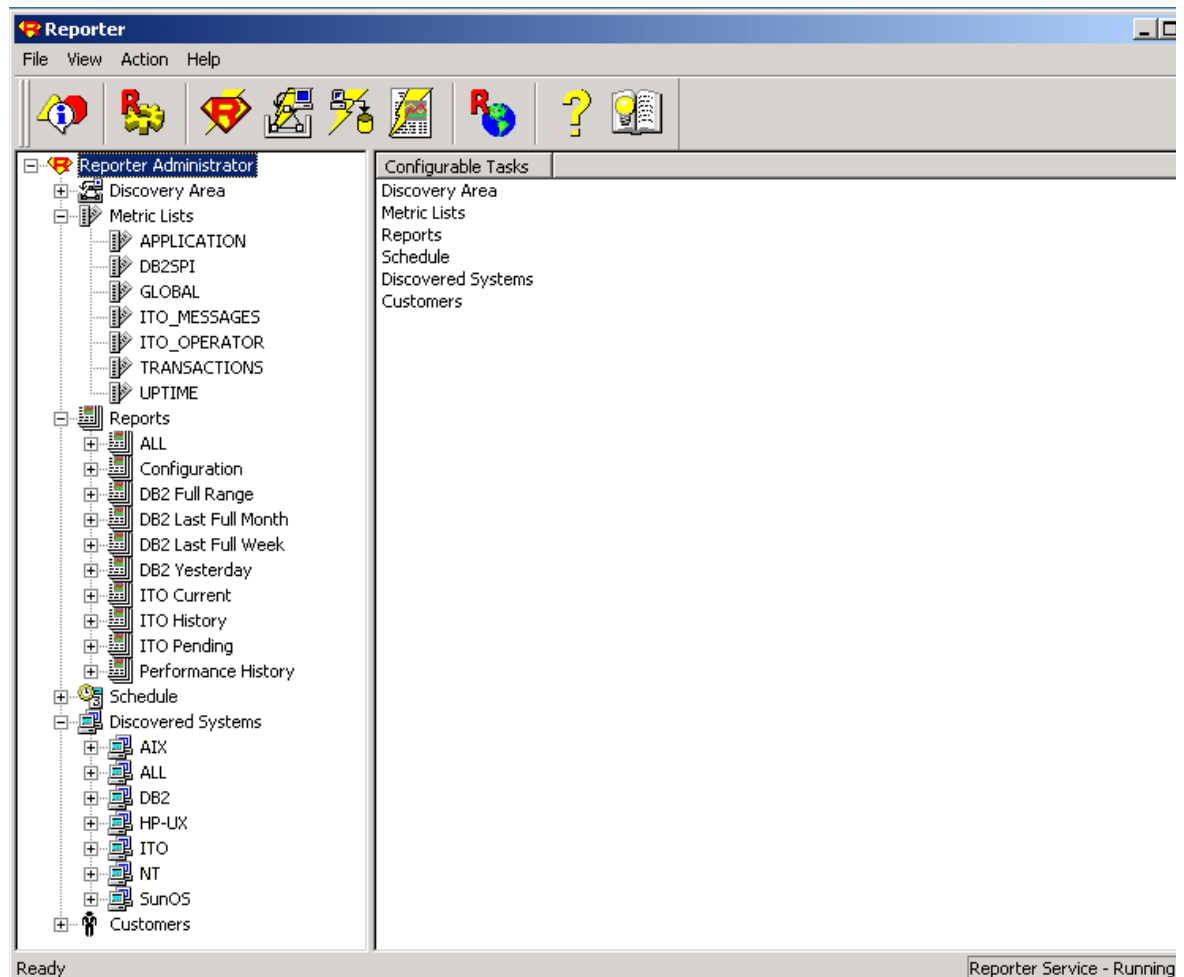
## Verification of correct Installation

After installation has finished, start OV Reporter and look for the following elements:

- New element "DB2" in the branch "Metric Lists", which contains a lot of individual metrics
- New elements in the "Reports" branch:
  - DB2 Full Range
  - DB2 Full Month
  - DB2 Full Week
  - DB2 Yesterday

In the OV Reporter GUI, this appears as follows:

**Figure 33: OV Reporter GUI with DB2SPI reports installed**



No special steps need to be taken to enable or activate the DB2SPI reports. They are prepared just like other reports.

## Creating Reports with the OV Reporter

DB2 information is collected with the OV Reporter just like other performance data.

With the integration of DB2SPI Reports into OV Reporter you are able to discover DB2 systems, gather data from them and put them into nice looking reports.

The reports created are stored in the Internet Information Server (IIS) of the OV Reporter system and can be accessed with a standard web browser.

### Looking at DB2 Reports

The URL of the reports is [http://<computername>/HPOV\\_Reports/db2spi/](http://<computername>/HPOV_Reports/db2spi/)

The DB2SPI comes with a set of ten different reports from four areas, all of which are evaluated and computed on a daily, weekly and monthly basis.

Report groupings and formats have been kept as close to HP's DBSPI as possible. This is to ensure homogeneity across different database SPIs projecting the same data (e.g. availability).

## DB2SPI Report Groups

### Availability Report Group

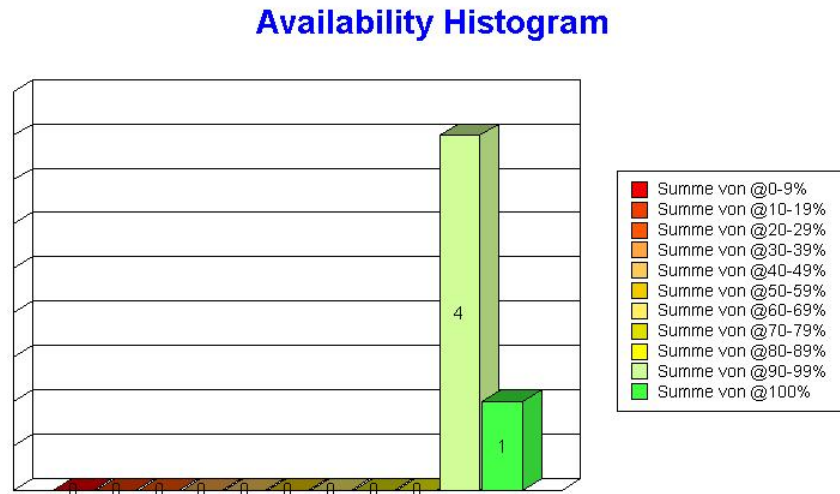
#### DB2 Database Availability

This report contains daily histograms showing the number (count) of databases in each range based on percent uptime. Ranges for uptime are 0-9%, 10-19%, 20-29%, 30-39%... 90-99% and 100%. The number of databases for a given range may be 0 to **xx**.

Tabular reports below each histogram show the minutes and percentage of uptime, downtime (quiescent pending, quiesced, rollforward and down) and unknown time for each database.

An example graph looks as follows:

Figure 34: OV Reporter: Availability Histogram



### DB2 Availability Details

This report contains spectrum reports showing minutes of uptime by day and hour for each database. There may be 1 to **xx** databases. The DB2SPI measures uptime and downtime in five-minute increments. Reports are based on uptime only (i.e. Status greater or equal 5).

The spectrum graphs use color to indicate how many minutes of uptime (i.e. up to 10 minutes, up to 20 minutes etc) were recorded during each hour of each day. One spectrum chart is produced for each database. The graphs are sorted by database name.

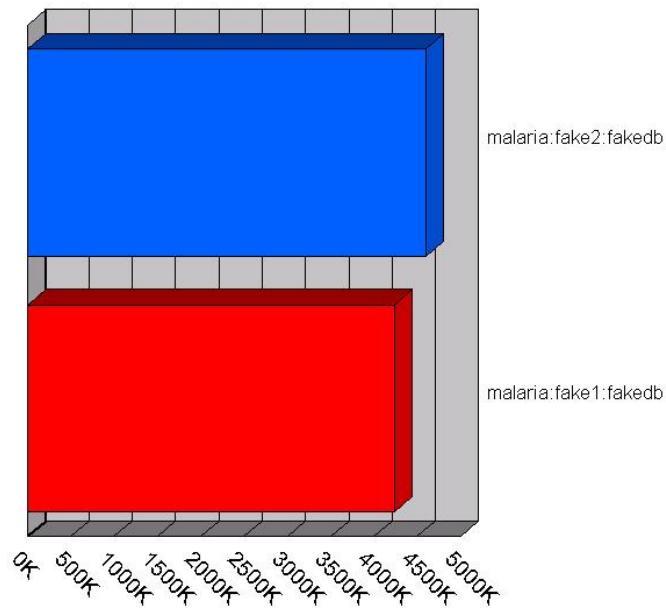
### I/O Report Group

#### Top 20 I/O

This report shows DB2 physical I/O i.e. the sum of buffer pool (index and data) reads and writes and direct reads and writes by database by day for the 20 databases with the most physical I/O during the reporting interval. The report is sorted by total physical I/O. The graph shows the top 20 databases in a horizontal stacked bar format for each day.



**Figure 35: OV Reporter: Availability**



### I/O Details

This report shows DB2 physical I/O by database by day. Physical I/O is represented by summing up "buffer pool (both index and data) reads and writes" and "direct reads and writes". The report is sorted by system name, instance name and database name.

## Workload Report Group

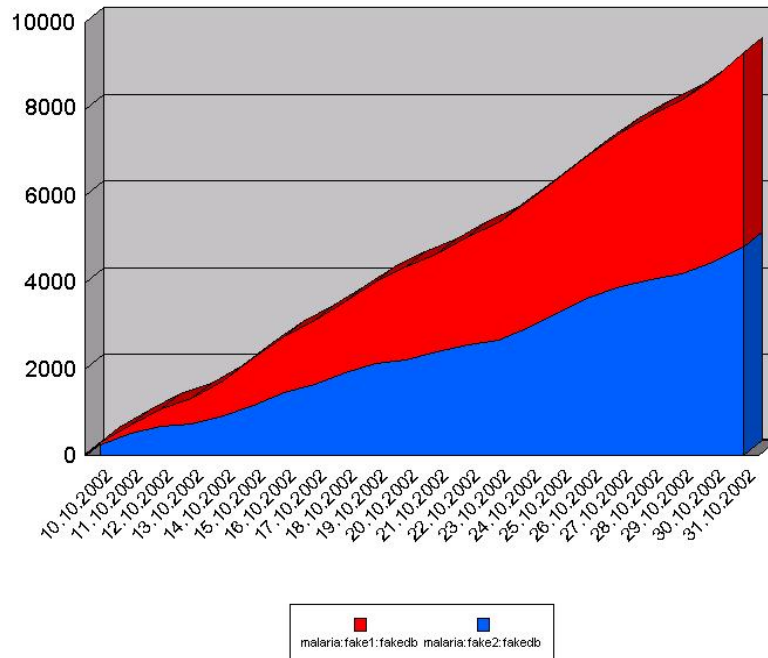
### DB2 Transactions

This report shows the transaction rate for DB2 databases. Transactions can be calculated as follows:

- commit statements attempted
  - + internal commits
  - + rollback statements attempted
  - + internal rollbacks

The stacked area graph and table show the average transactions per minute by database by day for the top 20 databases. The top instances are selected based on average transactions per minute over the entire reporting interval. The last tabular report should show the average, minimum and maximum transactions per minute for all databases. This table is sorted by instance name, database name and date.

**Figure 36: OV Reporter Graphs: DB Transactions**

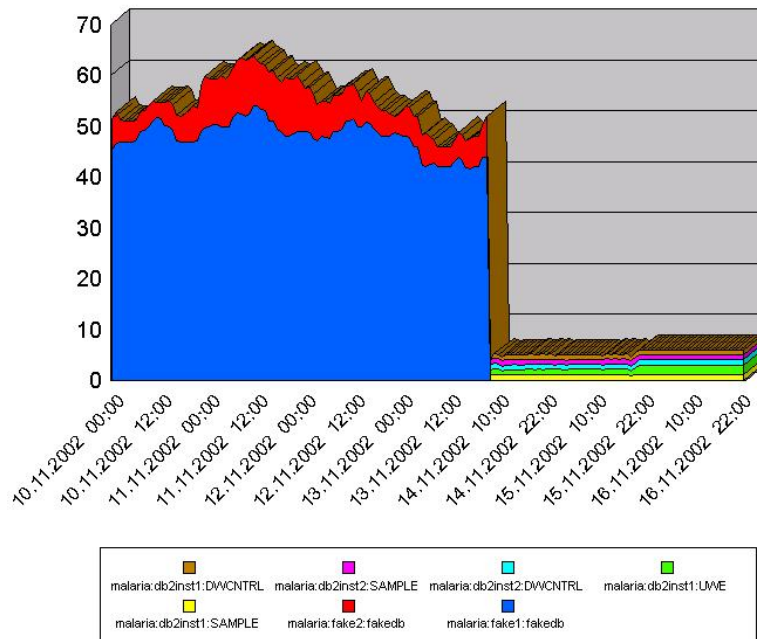


**DB2 current Connections / executing Connections**

This report shows the total number of connections per database. Current connections are the sum of local connections and remote connections. The stacked area graph and table show the average number of current connections by database by day for the top instances. The top instances are to be selected based on average number of current connections over the entire reporting interval. The last table shows the average, minimum and maximum number of current user logons for all instances. This table is sorted by instance name, database name and date.

An example graph looks as follows:

**Figure 37 OV Reporter Graph: DB2 Connections**



## OVO Report Group

### DB2SPI Active Messages

This report shows the top error messages, which were sent to ITO and had not been acknowledged at the time this report was prepared. These "miscellaneous" errors are usually a result of configuration problems or internal DB2SPI errors. Messages generated by successful processing of metrics or log files are not shown here. They are shown under the database reports. The graph shows the top messages by the DB2SPI error number or the first part of the text message. "Count" is used to show the number of duplicate messages for each object. In this report "Object" is based on the managed node name and the object field used in the ITO message. For DB2SPI error messages, the object usually describes either the database instance or the executable and module where the error occurred.

### DB2SPI Active Message Severity

This report should show the severity of DB-SPI error messages which were sent to ITO and were not acknowledged at the time the report was prepared. This report describes error message severity the following three ways:

1. A pie chart showing the message count by severity
2. Message counts for the top five databases broken down by severity
3. Message counts for all databases broken down by severity

### DB2SPI History Messages

This report shows the top error messages, which were sent to ITO, were acknowledged at the time this report was prepared. These "miscellaneous" errors are usually a result of configuration problems or

internal DB2SPI errors. Messages generated by successful processing of metrics or log files are not shown here. They are shown under the database reports. The graph shows the top messages by the DB2SPI error number or the first part of the text message. "Count" is used to show the number of duplicate messages for each object. In this report "Object" is based on the managed node name and the object field used in the ITO message. For DB2SPI error messages, the object usually describes either the database instance or the executable and module where the error occurred.

### DB2SPI History Message Severity

This report should show the severity of DB2SPI error messages, which were sent to ITO and were acknowledged at the time the report was prepared. This report describes error message severity the following three ways:

- 1 1. A pie chart showing the message count by severity
- 2 2. Message counts for the top five databases broken down by severity
- 3 3. Message counts for all databases broken down by severity

# 14 Appendix C: DB2SPI Licensing

## Licensing Policy

The DB2SPI requires a runtime license for each node where it is operated. Although some functions and policies may work also without a runtime license, all the critical functions and DB2 access is restricted by the license enforcement process.

The following elements are required for valid runtime license:

Version of the DB2SPI (actually A.02.1003.00)

Tier of the managed node (according to the HP OV Tiering Matrix)

Name or IP address of the managed node

Expiry date

Two different kinds of runtime licenses are available:

Evaluation runtime licenses are not restricted in their name or IP space, hence can be operated on any node, but will expire at some time. The DB2SPI comes with such an evaluation license that allows every user to start with the DB2SPI right away.

A customer runtime license is restricted to the node name or IP address specified when requesting the license, but has no time limit.


## How to obtain Runtime Licenses

Runtime Licenses can be obtained very easily via the secure NiCE Customer Portal  
<https://portal.nice.de/login.php>

Please make sure that you create your account there as soon as you have acquired your DB2SPI.

In the "Licenses" area of your personalized view you can request evaluation and production runtime licenses, which are created automatically and then can be downloaded directly via your web browser.

When changing your system (moving the DB2SPI to another node), simply flag the former system and enter the new data to create an update.

 Note that SPI licenses obtained from HP only serve as "installation licenses" on the management server, but not as "runtime licenses" on managed nodes.

Those installation licenses should not be entered into the "License Add" tool. It will corrupt the runtime license file.

## Install and activate a DB2SPI Runtime License

License management consists of two simple steps on the OVO Management Server.

Whenever you have received a new runtime license file, run the "License Add" tool and specify the name of the new file. This adds the new runtime license strings to the runtime license files for all supported platforms.

Deploy the "instrumentation" resp. "monitors" to all DB2SPI managed nodes.

The scripts and binaries on the managed nodes will scan the local license file db2s\_licenses.dat for a matching, valid runtime license on the respective node.

## Tools for License Management

There are three tools in the DB2SPI that help to maintain the runtime licenses:

### License Add:

This tool allows the addition of new runtime licenses on the management server.

### License List:

This tool lists all runtime licenses currently available on the management server. However, they must be deployed to the managed nodes in order to be active.

### License Check:

This tool verifies on a managed node if there are one or more valid runtime licenses for this node. Licenses may become invalid if time expires (only evaluation and test licenses) or if the node name has changed.

Details can be found in the "Using DB2SPI" section earlier in this User's Guide, chapter "DB2SPI License Tools" on page 53.