



# HP ALM Performance Center

Software Version: 12.50

## Installation Guide

Document Release Date: September 2015  
Software Release Date: September 2015

## Legal Notices

### Warranty

The only warranties for HP products and services are set forth in the express warranty statements accompanying such products and services. Nothing herein should be construed as constituting an additional warranty. HP shall not be liable for technical or editorial errors or omissions contained herein.

The information contained herein is subject to change without notice.

### Restricted Rights Legend

Confidential computer software. Valid license from HP required for possession, use or copying. Consistent with FAR 12.211 and 12.212, Commercial Computer Software, Computer Software Documentation, and Technical Data for Commercial Items are licensed to the U.S. Government under vendor's standard commercial license.

### Copyright Notice

© Copyright 2002 - 2015 Hewlett-Packard Development Company, L.P.

### Trademark Notices

Adobe™ is a trademark of Adobe Systems Incorporated.

Microsoft® and Windows® are U.S. registered trademarks of Microsoft Corporation.

UNIX® is a registered trademark of The Open Group.

This product includes an interface of the 'zlib' general purpose compression library, which is Copyright © 1995-2002 Jean-loup Gailly and Mark Adler.

## Documentation Updates

The title page of this document contains the following identifying information:

- Software Version number, which indicates the software version.
- Document Release Date, which changes each time the document is updated.
- Software Release Date, which indicates the release date of this version of the software.

To check for recent updates or to verify that you are using the most recent edition of a document, go to:

<https://softwaresupport.hp.com>.

This site requires that you register for an HP Passport and sign in. To register for an HP Passport ID, go to

<https://softwaresupport.hp.com> and click **Register**.

## Support

Visit the HP Software Support Online web site at: <https://softwaresupport.hp.com>

This web site provides contact information and details about the products, services, and support that HP Software offers.

HP Software online support provides customer self-solve capabilities. It provides a fast and efficient way to access interactive technical support tools needed to manage your business. As a valued support customer, you can benefit by using the support web site to:

- Search for knowledge documents of interest
- Submit and track support cases and enhancement requests
- Download software patches
- Manage support contracts
- Look up HP support contacts
- Review information about available services
- Enter into discussions with other software customers
- Research and register for software training

Most of the support areas require that you register as an HP Passport user and sign in. Many also require a support contract. To register for an HP Passport ID, go to: <https://softwaresupport.hp.com> and click **Register**.

To find more information about access levels, go to: <https://softwaresupport.hp.com/web/softwaresupport/access-levels>.

### HP Software Solutions & Integrations and Best Practices

Visit **HP Software Solutions Now** at <https://h20230.www2.hp.com/sc/solutions/index.jsp> to explore how the products in the HP Software catalog work together, exchange information, and solve business needs.

Visit the **Cross Portfolio Best Practices Library** at <https://hpln.hp.com/group/best-practices-hpsw> to access a wide variety of best practice documents and materials.



# Part 1: Getting Started



# Chapter 1: Before You Install

This chapter provides information that will help you prepare for the Performance Center component installations.

This chapter includes:

- Performance Center Components and Data Flow ..... 8
- System Component Considerations .....13
- Windows System Locale Considerations .....16
- Required Services .....17
- Performance Center Prerequisite Software .....17
- Pre-installation Considerations ..... 22

## Performance Center Components and Data Flow

This section describes the HP ALM Performance Center system.

This section includes:

- ["Architecture and Components" below](#)
- ["Applications " on the next page](#)
- ["Communication Paths" on the next page](#)
- ["Coexistence of Installed Components" on page 11](#)
- ["Load Considerations" on page 12](#)

### Architecture and Components

This section describes the architecture and components of HP ALM Performance Center.

| Architecture/Component              | Description   |
|-------------------------------------|---|
| <b>ALM server</b>                   | <p>Provides a platform for core ALM functionality.</p> <ul style="list-style-type: none"><li>• <b>ALM Client.</b> Users log in to ALM (user site), Site Administration (project and user management), or Lab Management from their client machine.</li><li>• <b>ALM Server Repository.</b> Used for file storage.</li><li>• <b>ALM Database.</b> Contains a schema per Performance Center project, as well as a separate schema for Lab Management and Site Administration.</li></ul> <p>For more details about ALM technology, see the HP Application Lifecycle Management Installation and Upgrade Guide.</p>   |
| <b>HP Performance Center Server</b> | <p>Hosts the Performance Center Web pages that enable you to design performance tests, configure monitors, reserve testing resources, run and monitor test runs, and analyze test results.</p>  |
| <b>Lab Management</b>               | <p>The center for managing lab resources (such as hosts and host pools), and for managing Performance Center assets (such as Performance Center server, licenses, and usage reports).</p>   |
| <b>HP Performance Center Hosts</b>  | <p>Used to control performance tests, generate load, and analyze data. Performance Center hosts can be configured as Controllers, load generators, or data processors:</p> <ul style="list-style-type: none"><li>• <b>Controller.</b> The manager of a performance test. The Controller receives scripts, runtime settings, and a list of load generators to use. The Controller issues instructions to the load generators including which scripts to run, how many Vusers to run per script, and scheduler settings. At the conclusion of the test run, the Controller collates the data. There is only one Controller per performance test.</li><li>• <b>Load Generator.</b> Generate load by running virtual users (Vusers). The Controller dictates the manner in which they start and stop running. There can be any number of load generators for a given test.</li><li>• <b>Data Processor.</b> Used for analyzing and publishing performance test results.</li></ul> |



## Applications

The following standalone applications integrate with your Performance Center system:

| Application                              | Description   |
|--|---|
| <b>HP Virtual User Generator (VuGen)</b> | Generates Vusers by recording actions that typical end-users would perform on your application. VuGen records your actions into automated Vuser scripts which form the foundation of your performance tests.  |
| <b>HP Analysis</b>                       | Provides graphs and reports with in-depth performance analysis information. Using these graphs and reports, you can pinpoint and identify the bottlenecks in your application and determine what changes need to be made to your system to improve its performance.   |
| <b>HP Network Virtualization (NV)</b>    | Installs HP Network Virtualization for the Performance Center machine.  |
| <b>MI Listener</b>                       | Needed when running Vusers and monitoring applications over a firewall.   |
| <b>Monitors Over Firewall Agent</b>      | Used to monitor servers that are located over a firewall.   |
| <b>PAL Data Set Creator</b>              | This tool enables you to create production data sets. After creating the data sets, you can upload them from PAL and use them in your reports. You can create IIS W3C, Apache logs, Google Analytics, Webtrends, or RUM datasets. For more details, see the PAL section in the <i>HP ALM Performance Center Guide</i> . |
| <b>Snapshot Viewer</b>                   | Enables you to view snapshot-on-error pages captured from Web Vusers during performance test runs. The viewer displays snapshots from files with .SOE and .INF extensions. A Snapshot on Error (.SOE) file is a zipped file containing one or more snapshots in .INF format.  |
| <b>TruClient Standalone</b>              | Installs TruClient as a standalone application. Install this tool to record Web applications with TruClient technology. You save the recordings to a script that can be used in a performance test run.   |

Use the diagram and table in the "[Communication Paths](#)" and "[Load Considerations](#)" sections, to determine which machines to allocate for which performance testing tasks.

For example, you can combine a number of components that have a light load on a single machine. For details on which components can be installed together, see "[Coexistence of Installed Components](#)" on [page 11](#).

For information on installing the standalone applications, see "[Installing Additional Components](#)" on [page 48](#).

## Communication Paths

When installing HP ALM Performance Center, it is important to consider the communication paths between the various components, and their resource demands. This information helps you configure your system to evenly distribute the load, and prevent overloading any particular resource.

When running a performance test, Performance Center components share information with ALM components via a distinct system of communication. Understanding which components communicate with one another and the method of communication is essential for configuring your system.

The following diagram illustrates the communication paths of the ALM Performance Center system:

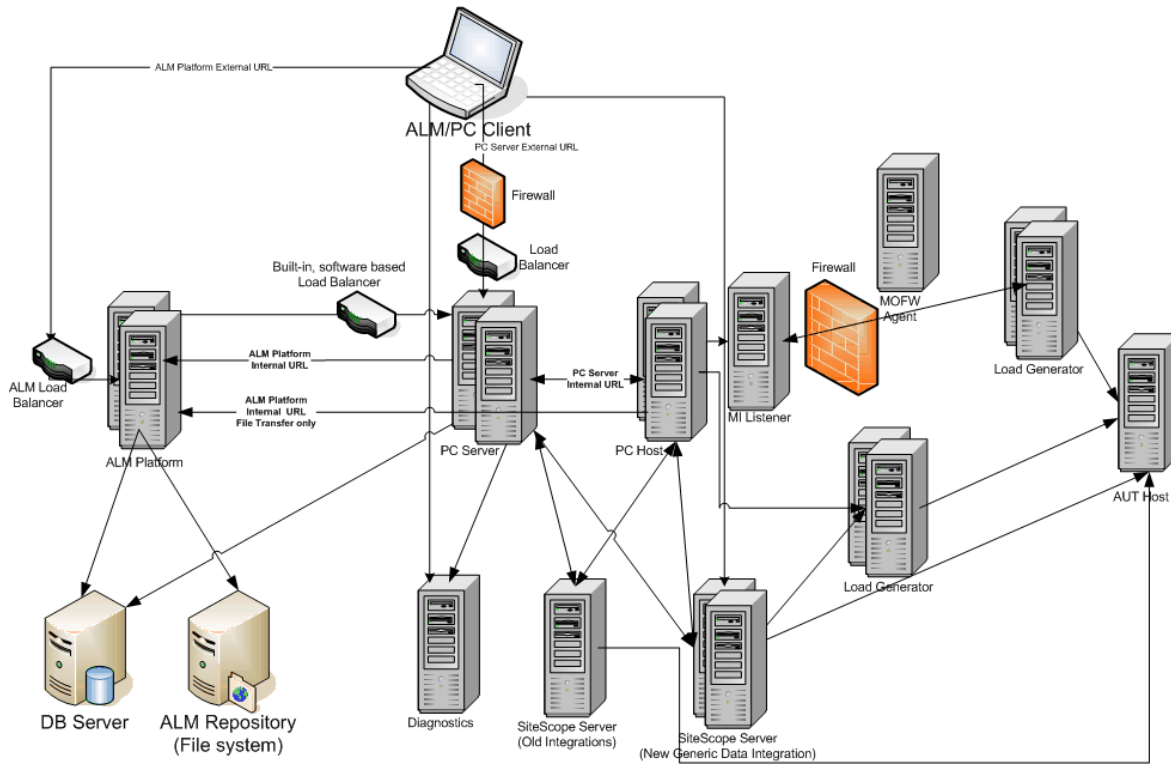

The following table displays the connection ports that must be opened for the incoming traffic on the various ALM Performance Center components:

**Note:** If the installation cannot use a default port because it is already in use, you can change the port. For more details, see ["Installing One of the Performance Center Components Cannot Use Default Port: Port Already in Use"](#) on page 124.

| Component                        | Ports  |
|----------------------------------|--|
| <b>ALM server</b>                | HTTP for Jetty Web server: 8080 * **<br>HTTP for IIS Web server: 80 * ** |
| <b>Performance Center Server</b> | HTTP (80) * **<br>TCP (3333, 54245)                                      |
| <b>Performance Center Host</b>   | HTTP (8731)<br>TCP (3333, 5001, 5002, 5003, 54245, 54345)                |
| <b>Database</b>                  | TCP (1433 (SQL)), 1521 (Oracle) **                                       |

| Component                           | Ports   |
|-------------------------------------|---|
| <b>Repository</b>                   | NetBIOS   |
| <b>Diagnostics Server</b>           | HTTP (80, 2006) *<br>TCP (54345)  |
| <b>Standalone Load Generator</b>    | TCP (5001, 5002, 5003, 54245, 54345)  |
| <b>Cloud-based Load Generator</b>   | As defined in the Cloud Network Settings dialog box. For more details, see the <i>HP ALM Lab Management Guide</i> . |
| <b>MI Listener</b>                  | HTTP/TCP (443) **<br>TCP (50500)  |
| <b>Application under test</b>       | Any; HTTP (Random)  |
| <b>SiteScope - Topology</b>         | HTTP (8080) *   |
| <b>SiteScope - Monitor Profiles</b> | HTTP (8888) *   |

\* HTTPS is also supported on this component.

\*\* Default values that can be changed during configuration

## Coexistence of Installed Components

The following table describes which components can coexist on the same machine.

| Installed Application        | Need to Install |          |       |      |             |    |                 |    |     |      |              |
|------------------------------|-----------------|----------|-------|------|-------------|----|-----------------|----|-----|------|--------------|
|                              | Analysis SA     | VuGen SA | LG SA | MOFW | MI Listener | DM | Snapshot Viewer | LR | PCS | Host | TruClient SA |
| Analysis SA                  | --              | Yes      | No    | No   | No          | No | Yes             | No | No  | No   | Yes          |
| VuGen SA                     | Yes             | --       | No    | No   | No          | No | Yes             | No | No  | No   | No           |
| Load Generator SA            | No              | No       | --    | No   | No          | No | No              | No | No  | No   | No           |
| Monitor Over Firewall (MOFW) | No              | No       | No    | --   | No          | No | No              | No | No  | No   | No           |
| MI Listener                  | No              | No       | No    | No   | --          | No | No              | No | No  | No   | No           |
| Diagnostics Mediator (DM)    | No              | No       | No    | No   | No          | -- | No              | No | No  | No   | No           |
| Snapshot Viewer              | Yes             | Yes      | No    | No   | No          | No | --              | No | No  | No   | No           |
| LoadRunner (LR)              | No              | No       | No    | No   | No          | No | No              | -- | No  | No   | No           |
| Performance Center           | No              | No       | No    | No   | No          | No | No              | No | --  | No   | No           |

|              |     |    |    |    |    |    |    |    |    |    |    |
|--------------|-----|----|----|----|----|----|----|----|----|----|----|
| Server (PCS) |     |    |    |    |    |    |    |    |    |    |    |
| Host         | No  | No | No | No | No | No | No | No | No | -- | No |
| TruClient SA | Yes | No | No | No | No | No | No | No | No | No | -- |

SA = Standalone

## Load Considerations

The following table provides some basic installation considerations for each Performance Center component:

| Machine   | Quantity in the system                              | Load Considerations  |
|---|---|--|
| <b>Performance Center Server</b>  | At least two  | <p>Heavy load.</p> <p>To balance the load, ALM has built in load balancing capabilities.</p> <p>For additional load balancing support, you can install multiple Performance Center Servers.</p> <p>For more information on load balancing, see HP Software Self-solve knowledge base article KM1052520 (<a href="https://softwaresupport.hp.com/group/softwaresupport/search-result/-/facetsearch/document/KM1052520">https://softwaresupport.hp.com/group/softwaresupport/search-result/-/facetsearch/document/KM1052520</a>).</p>  |
| <b>Performance Center Hosts: Controller, Load Generator, and Data Processor</b> | At least one of each                                | <p>Controller has heavy load.</p> <p>Load generator has medium load.</p> <p>Data processor has medium to high load.</p> <p>It is recommended to designate spare Controllers and load generators for fault-tolerance and high availability purposes.</p> <p><b>Note:</b></p> <ul style="list-style-type: none"> <li>You can configure a host as a Controller + Load Generator, but this is not recommended because running Vusers consumes a lot of resources. Running Vusers on the Controller host is only appropriate for performance tests that have a very small number of Vusers.</li> <li>You can configure a host as a Controller + Data Processor, but this is not recommended because data processing might consume high amounts of CPU and resources.</li> </ul> |
| <b>MI Listener</b>  | At least one, if you are monitoring over a firewall | <p>Medium load.</p> <ul style="list-style-type: none"> <li>Standalone installation is required.</li> <li>Cannot exist on a machine running IIS.</li> </ul>   |
| <b>Monitor Over Firewall machine</b>  | At least one, if you are monitoring over a firewall | <p>Light load.</p> <p>Standalone installation is required.</p>   |

| Machine              | Quantity in the system | Load Considerations |
|----------------------|------------------------|---------------------|
| SiteScope (optional) | One                    | Light load.         |

## System Component Considerations

The Performance Center system includes several components. This section provides pre-installation considerations for each of the components.

For system requirement details for each component, see the *HP Application Lifecycle Management Readme*.

- "Performance Center Server" below
- "Performance Center Host" on page 15
- "Standalone Load Generator (Windows)" on page 15
- "Standalone Load Generator (Linux)" on page 15
- "Standalone VuGen and Standalone Analysis" on page 15
- "MI Listener" on page 16
- "Monitor Over Firewall Machine" on page 16
- "ERP and CRM Mediator" on page 16
- "SiteScope Server" on page 16

## Performance Center Server

- Uninstall any previous installations of the Performance Center Server from your machine.

**Note: Performance Center 11.52 or 11.52 Patch 1:** After uninstalling Performance Center, the Performance Center installer does not remove all of the related configuration settings. Prior to installing Performance Center 12.50, make sure to remove the configuration settings. For more details, see HP Software Self-solve knowledge base article KM01174822

<https://softwaresupport.hp.com/group/softwaresupport/search-result/-facetsearch/document/KM01174822>).

- For best results, install the Performance Center Server on a clean machine with a new image.
- Performance Center Servers conduct Performance Center administration, test design, run operations, monitoring, and the user interface services for these operations. Because performance test run operations create heavy load on the Performance Center Server, we recommend installing **at least two Performance Center Servers** in your system. Using built-in load balancers, calls from ALM to Performance Center Servers are balanced among the Performance Center Servers in a round-robin fashion.
- Before you install the Performance Center Server, you must install Microsoft Internet Information

Services (IIS 7.5/8.0/8.5).

- During installation, some IIS features are updated on all Performance Center Servers using IIS.

The following features are enabled:

- Active Server Pages
- ASP.NET 4.0 (IIS 7.5)
- ASP.NET 4.5 (IIS 8.0/8.5)
- Metabase
- Static content
- IIS 6.0 Management Compatibility
- Dynamic Compression

The following features are disabled:

- URL Authorization
- To install a Performance Center Server, you must have full local administrative rights on the designated machine.
- The Performance Center Server requires a specific Windows user to be defined on the machine. When using the default user or a custom local user, the user will be created on the machine and will be added to the Administrator group. Ensure that there is no security system in place that will prevent creating the user or that will remove the user from the Administrators group. For more information on how to create this user, see ["Installing and Configuring Performance Center Servers and Hosts" on page 29](#)
- If Performance Center is working with an Oracle database, ensure that the Oracle client installed on the Performance Center Server machine is at least the same version as on the Oracle server, and that connectivity is established with the Oracle Server. For details, see ["Establishing Connectivity with Oracle" on page 67](#).
- You must install the 32-bit Oracle client installation, regardless of whether you are running the Performance Center Server on a 32-bit or 64-bit operating system.
- If you install the Oracle client after installing the Performance Center Server, you **must** restart the machine after installing the Oracle client.
- Oracle Monitoring: If you need to define Oracle monitors, ensure that you install the Performance Center Server in a directory whose path does not include any of the following characters: ( ) ; \* \ / " ~ & ? { } \$ % | < > + = ^ [ ]. For example, on a 64-bit machine, do not install the Performance Center Server in the default installation directory (**C:\Program Files (x86)\...**), as this path includes illegal characters.
- Microsoft Windows Script Host should be version 5.6 or later. To verify the version number, navigate to the **<Windows installation directory>\Windows\system32** directory. Right-click **wscript.exe** and select **Properties**. In the **Version** tab, verify the file version number.

## Performance Center Host

- Uninstall any previous installations of Performance Center hosts from your machine.

**Note: Performance Center 11.52 or 11.52 Patch 1:** After uninstalling Performance Center, the Performance Center installer does not remove all of the related configuration settings. Prior to installing Performance Center 12.50, make sure to remove the configuration settings. For more details, see HP Software Self-solve knowledge base article KM01174822

<https://softwaresupport.hp.com/group/softwaresupport/search-result/-facetsearch/document/KM01174822>.

- To install a Performance Center Host, you must have full local administrative rights on the designated machine.
- The Performance Center Host requires a specific Windows user to be defined on the machine. This user is configured when adding the Host to Lab Management. When using a default user or a custom local user, the user will be created on the machine and added to the Administrators group. Ensure that there is no security system in place that will prevent creating the user or that will remove the user from the Administrators group. For more information on how to create this user, see "[Installing and Configuring Performance Center Servers and Hosts](#)" on page 29

## Standalone Load Generator (Windows)

- You cannot install the Standalone Load Generator on the same machine as the Performance Center Server or Performance Center host.
- During installation of the Standalone Load Generator, the default Performance Center system user, **IUSR\_METRO** (password **P3rfoRm@1nce**), is created in the **Administrators** user group of the machine. Ensure that there is no security system in place that will remove the system user from the Administrators group.

## Standalone Load Generator (Linux)

You can install the Standalone Load Generator on Linux to run Vusers. The Linux Vusers interact with the Controller that is installed on a Windows machine. For more information, see [Installing HP Load Generator on Linux](#).

## Standalone VuGen and Standalone Analysis

If you are installing the Standalone Load Generator on the same machine as Standalone applications (VuGen or Analysis), install the Standalone applications first, and the Standalone Load Generator last.

## MI Listener

- The MI Listener must be installed on a standalone machine.
- The MI Listener cannot be installed on a machine running IIS.

## Monitor Over Firewall Machine

The Monitor Over Firewall agent must be installed on a standalone machine.

## ERP and CRM Mediator

- The ERP and CRM Mediator must be installed on a machine that resides in the same LAN as the monitored ERP/CRM server, preferably on a dedicated machine. It is not recommended to install the Mediator on a Siebel or Oracle server that is involved in the performance test.

**Note:** When using SAP Diagnostics, ensure that a SAPGUI client is installed on the same machine as the ERP/CRM Mediator.

- By default, the ERP/CRM Mediator agent is installed to run as a service. After installing the agent, verify that it is running as a service and not as a process. If it is running as a process, you must stop the process and run the agent as a service.
- For information about configuring the ERP/CRM Mediator after installation and using the ERP and CRM Mediator to collect diagnostics data, see the HP ALM Performance Center Guide.

## SiteScope Server

- SiteScope is used for monitoring applications.
- Refer to the *HP SiteScope Deployment Guide* for minimum requirements.

## Windows System Locale Considerations

The Windows system locale (Culture and UI Culture) of the user running the Performance Center environment (IUSR\_METRO unless changed) must match the localized version of your Performance Center software. When working with a non-localized version of Performance Center, the locale must be set to English (EN-xx). Since the Performance Center user is created and configured when the machine is added to the LAB project, the system locale needs to be verified after completing all of the configuration steps.



For more details on setting the Windows system locale, see HP Software Self-solve knowledge base article KM01215254 (<https://softwaresupport.hp.com/group/softwaresupport/search-result/-/facetsearch/document/KM01215254>).

## Required Services

Before you install Performance Center components, check that the services defined in the table below are running on each component machine and that the startup type for each service is defined as **Automatic**.

**Note:** The default settings for running the services on the operating system may differ from one version to another. You should go through all of the services on each machine to ensure that the required services are running.

| Machine   | Services  |
|---|---|
| <b>All Performance Center Servers and Hosts</b> | <ul style="list-style-type: none"><li>• IPsec Policy Agent (for TCP/IP security)</li><li>• Remote Procedure Call (RPC)</li><li>• Windows Management Instrumentation (for Performance Center health check)</li><li>• Windows Event Log (optional— used for debugging)</li><li>• COM+ services (Event System and System application)</li><li>• System Event Notification (for COM+)</li></ul> |
| <b>Performance Center Servers</b>               | <ul style="list-style-type: none"><li>• IIS Admin Service (Microsoft Service)</li><li>• Workstation</li><li>• TCP/IP NetBIOS Helper</li><li>• World Wide Web Publishing Service (Microsoft Service)</li><li>• Distributed Transaction Coordinator (MSDTC)</li></ul>   |
| <b>Performance Center Hosts</b>                 | <ul style="list-style-type: none"><li>• Remote Registry Service (requires for host monitor)</li></ul>   |

## Performance Center Prerequisite Software

Before you can install Performance Center, some prerequisite software must be installed on your machine. During installation, Performance Center checks whether the prerequisite software is installed on your machine. Performance Center enables you to automatically install missing software from the Performance Center disk.

The following table provides a list of the prerequisite software and how Performance Center detects whether the software is installed.

| Prerequisite Software  | Machines  | Means of detection  |
|--|---|---|
| .Net Framework 4.5.1   | <ul style="list-style-type: none"> <li>All Performance Center Server and Host machines</li> <li>Standalone VuGen</li> <li>Standalone Load Generator</li> <li>Standalone Analysis</li> </ul> | <p>Searches the registry key for the <code>Release</code> value. Its expected value should be greater than 378675:</p> <p>HKLM\SOFTWARE\Microsoft\NET Framework Setup\NDP\v4\Full</p> <div style="border: 1px solid green; padding: 5px; margin-top: 10px;"> <p><b>Note:</b> .Net Framework 4.5.1 replaces the .Net Framework 4.0 files. If there are any applications that are using the .Net Framework 4.0 files and are running during the installation of .Net Framework 4.5.1, you may need to restart your machine. If you are prompted to restart the machine, restart it before continuing the installation. For more information, see: <a href="http://msdn.microsoft.com/en-us/library/527997%28v=vs.110%29.aspx">http://msdn.microsoft.com/en-us/library/527997%28v=vs.110%29.aspx</a>.</p> </div> |
| Microsoft Data Access Components (MDAC) 2.8 SP1 (or later)                           | <ul style="list-style-type: none"> <li>All Performance Center Server and Host machines</li> <li>Standalone VuGen</li> <li>Standalone Analysis</li> <li>Standalone Load Generator</li> </ul> | <p>Searches the registry key:</p> <p>HKLM\Software\Microsoft\Data Access</p>  |
| Microsoft Core XML Services (MSXML) 6.0  | <ul style="list-style-type: none"> <li>All Performance Center Server and Host machines</li> <li>Standalone VuGen</li> <li>Standalone Analysis</li> <li>Standalone Load Generator</li> </ul> | <p>Queries the existence and version of:</p> <p>%systemroot%\system32\msxml6.dll</p>  |
| Microsoft Visual C++ 2005 Service Pack 1 Redistributable Package MFC Security Update | <ul style="list-style-type: none"> <li>All Performance Center machines</li> <li>Standalone VuGen</li> </ul>   | <p>Queries the MSI manager for the GUID:</p> <p>{86C9D5AA-F00C-4921-B3F2-C60AF92E2844}</p>  |

| Prerequisite Software  | Machines  | Means of detection  |
|--|---|---|
| (x86)  | <ul style="list-style-type: none"> <li>• Standalone Analysis</li> <li>• Standalone Load Generator</li> </ul>  |   |
| Microsoft Visual C++ 2005 Service Pack 1 Redistributable Package MFC Security Update (x64) | <ul style="list-style-type: none"> <li>• All Performance Center machines</li> <li>• Standalone VuGen</li> </ul>   | Queries the MSI manager for the GUID:<br>{A8D19029-8E5C-4E22-8011-48070F9E796E} |
| Microsoft Visual C++ 2008 Service Pack 1 Redistributable Package MFC Security Update (x86) | <ul style="list-style-type: none"> <li>• All Performance Center machines</li> <li>• Standalone VuGen</li> <li>• Standalone Analysis</li> <li>• Standalone Load Generator</li> </ul>                 | Queries the MSI manager for the GUID:<br>{DE2C306F-A067-38EF-B86C-03DE4B0312F9} |
| Microsoft Visual C++ 2008 Service Pack 1 Redistributable Package MFC Security Update (x64) | <ul style="list-style-type: none"> <li>• All Performance Center machines</li> <li>• Standalone VuGen</li> </ul>   | Queries the MSI manager for the GUID:<br>{FDA45DDF-8E17-336F-A3ED-356B7B7C688A} |
| Microsoft Visual C++ 2010 Service Pack 1 Redistributable Package MFC Security Update (x86) | <ul style="list-style-type: none"> <li>• All Performance Center Server and Host machines</li> <li>• Standalone VuGen</li> <li>• Standalone Analysis</li> <li>• Standalone Load Generator</li> </ul> | Queries the MSI manager for the GUID:<br>{1F4F1D2A-D9DA-32CF-9909-48485DA06DD5} |

| Prerequisite Software                         | Machines  | Means of detection   |
|---|---|--|
| Microsoft Visual C++ 2012 Redistributable     | <ul style="list-style-type: none"> <li>• All Performance Center Server and Host machines</li> <li>• Standalone VuGen</li> <li>• Standalone Analysis</li> <li>• Standalone Load Generator</li> </ul> | Queries the MSI manager for the GUID:<br>{4121ED58-4BD9-3E7B-A8B5-9F8BAAE045B7}  |
| Microsoft Visual C++ 2012 Redistributable x64 | <ul style="list-style-type: none"> <li>• All Performance Center Server and Host machines</li> <li>• Standalone VuGen</li> <li>• Standalone Analysis</li> <li>• Standalone Load Generator</li> </ul> | Queries the MSI manager for the GUID:<br>{EFA6AFA1-738E-3E00-8101-FD03B86B29D1}  |
| Microsoft Visual C++ 2013 Redistributable     | <ul style="list-style-type: none"> <li>• All Performance Center Host machines</li> <li>• Standalone VuGen</li> <li>• Standalone Analysis</li> <li>• Standalone Load Generator</li> </ul>            | Queries the MSI manager for the GUID:<br>{936E696B-0C8D-3A48-98DF-344FEA4E1139}  |
| Microsoft Windows Installer 3.1               | <ul style="list-style-type: none"> <li>• All Performance Center Server and Host machines</li> <li>• Standalone VuGen</li> <li>• Standalone Analysis</li> </ul>                                      | Looks for one of the following: <ul style="list-style-type: none"> <li>• Registration of the WindowsInstaller.Installer.com object version 3 or later</li> <li>• MSI.dll version 3 or later in the %systemroot%</li> </ul> |

| Prerequisite Software  | Machines  | Means of detection  |
|--|---|---|
| Web Services Enhancements (WSE) 2.0 SP3 and 3.0 for Microsoft .NET (WSE prerequisites only required for running Web Services Vusers) | <ul style="list-style-type: none"> <li>PC Host (not installed automatically)</li> <li>Standalone Load Generator (installed automatically only on machines where .Net 3.5 is pre-installed)</li> </ul> | Queries the MSI manager for the GUIDs:<br>WSE 2.0 SP3: {DE6ECF6D-2979-4137-8B56-0339497275B6}<br>{89F62EE7-BAD4-482E-BEF1-AE4A2AD408B7}<br>WSE 3.0: {1093C60E-AF41-4DCC-90C8-876BA0E2A88B} {AC245E8D-C75F-4B53-A0CF-A9E47837C90E}             |
| Internet Information Services (IIS)  | <ul style="list-style-type: none"> <li>Performance Center Server</li> </ul>   | HKLM\SOFTWARE\Microsoft\InetStp<br>Looks for both Major and Minor numbers.<br>Supports following versions: <ul style="list-style-type: none"> <li>7.5 (Windows 2008 R2)</li> <li>8.0 (Windows 2112)</li> <li>8.5 (windows 2012 R2)</li> </ul> |
| Strawberry Pearl 5.10.1  | <ul style="list-style-type: none"> <li>Standalone VuGen</li> </ul>  | Queries the MSI manager for the GUID:<br>{C977182F-221A-337A-B681-963808E0023A}   |
| Windows Imaging Component (WIC)  | <ul style="list-style-type: none"> <li>All Performance Center Server and Host machines</li> <li>Standalone VuGen</li> <li>Standalone Analysis</li> <li>Standalone Load Generator</li> </ul>           | Queries the version of: %systemroot%\system32\WindowsCodecs.dll   |
| Java 2 Runtime Environment, Standard Edition 1.7.0_25 (x86)  | <ul style="list-style-type: none"> <li>All Performance Center Host machines</li> <li>Standalone Load Generator (Required for the HP)</li> </ul>   | Search registry key "HKLM\SOFTWARE\JavaSoft\Java Runtime Environment\1.7" for parameter 'MicroVersion'. The value should be greater or equal '0'.   |

| Prerequisite Software | Machines                            | Means of detection |
|-----------------------|-------------------------------------|--------------------|
|                       | Network Virtualization integration) |                    |

## Pre-installation Considerations

This section includes pre-installation considerations for all Performance Center components.

- To install a Performance Center Server or Performance Center host, you must have full local administrative rights on the designated machine.
- The Performance Center Server and the Performance Center host cannot be installed on the same machine.
- Before you begin installing, you should decide which machine is to be used for what purpose. Consider the expected load on each machine when determining which components to install on which machines. For more details, see "[Coexistence of Installed Components](#)" on page 11, and "[Load Considerations](#)" on page 12.
- To install Performance Center, you must first disable User Access Control (UAC). For details on how to disable UAC, see: <http://gallery.technet.microsoft.com/Registry-Key-to-Disable-UAC-45d0df25>.
- To install Performance Center, you must first disable the Data Execution Prevention (DEP). For details, see <http://support.microsoft.com/kb/875352>.
- If the Performance Center installation directory is located on a network drive, it is recommended to map the network drive before you run the installation.
- To enable running the installation from a network location, make sure that the network location path is added to the Trusted Sites of the machine on which you are running the installation.
- Ensure that the server time on the ALM server and Performance Center component machines is synchronized.
- If you are installing a Performance Center Server or Performance Center host using a Remote Desktop connection (RDP), you must connect using the Console session.
- If you are working with an Oracle database, ensure that the Oracle client is installed on the Performance Center Server (with **Administrator** installation type), and that connectivity has been established with the Oracle Server. Ensure that the **tnsnames.ora** file contains the same TNS entry for the source and target database server.

**Note:** You must install the 32-bit Oracle client installation, regardless of whether you are running the Performance Center Server on a 32-bit or 64-bit operating system.

- For installation of standalone applications, you must manually install the prerequisite software. For the list of required prerequisites, see "[Performance Center Prerequisite Software](#)" on page 17. For

details on installing the prerequisites in silent mode, see ["Installing Performance Center Silently" on page 39](#).

- You cannot install Performance Center components on machines with existing LoadRunner installations. Before installing Performance Center, ensure that you have removed all versions of LoadRunner from the machine.
- Ensure that the operating system and the database are both configured for the same language. If not, some texts displayed in Performance Center will be corrupted. For example, if you are working with German, ensure that you are working on a German operating system, and that the database is configured for German.
- When ALM is configured to use SSL for DB connectivity, the Performance Center server will also connect to the DB using SSL. Verify that the CA that signed the certificate used by the DB server is trusted by the Performance Center server. The CA should be defined in the Windows certificate store on the machine level under "Trusted Root Certification Authorities" (**certmgr.msc**).





# Part 2: Installation and Configuration



# Chapter 2: Installing HP ALM Performance Center

This chapter describes how to install HP ALM Performance Center.

This chapter includes:

- [Installation Flow](#) .....28
- [Installing HP Application Lifecycle Management](#) ..... 29
- [Installing and Configuring Performance Center Servers and Hosts](#) .....29
- [Configuring Performance Center in Lab Management](#) .....36
- [Installing Performance Center Silently](#) .....39
- [Installing Standalone Components \(Windows\)](#) .....45
- [Installing Additional Components](#) ..... 48
- [Uninstalling Performance Center Server and Hosts](#) .....49
- [Uninstalling the HP Load Generator from Linux](#) ..... 50

# Installation Flow

This section describes the steps required to install HP ALM Performance Center.

|  |  |
|--|--|
| <p style="text-align: center;">Review<br/>Pre-installation Considerations</p>     | <p>Before beginning the actual installation procedure, check that you meet the prerequisite criteria for working with Performance Center. For details, see "<a href="#">Before You Install</a>" on page 7</p>  |
| <p style="text-align: center;">Uninstall Performance Center</p>                   | <p>Uninstall the existing version of Performance Center from the machine. For details, see "<a href="#">Uninstalling Performance Center Server and Hosts</a>" on page 49.</p>  |
| <p style="text-align: center;">Install ALM</p>                                    | <p>Install the ALM server. For details, see "<a href="#">Installing HP Application Lifecycle Management</a>" on the next page</p>  |
| <p style="text-align: center;">Install and Configure Performance Center</p>       | <ol style="list-style-type: none"> <li>1. Install and configure Performance Center servers and hosts. For details, see "<a href="#">Installing and Configuring Performance Center Servers and Hosts</a>" on the next page.</li> <li>2. Configure Performance Center in Lab Management. For details, see "<a href="#">Configuring Performance Center in Lab Management</a>" on page 36.</li> </ol>            |
| <p style="text-align: center;">Install Standalone Components</p>                | <ul style="list-style-type: none"> <li>• Install standalone applications that provide advanced features for working with Performance Center. For details, see "<a href="#">Installing Standalone Components (Windows)</a>" on page 45</li> <li>• To install a load generator on Linux, see <a href="#">Installing HP Load Generator on Linux</a>.</li> </ul>   |
| <p style="text-align: center;">Perform Additional Tuning and Configuration</p>  | <ul style="list-style-type: none"> <li>• Perform additional tuning and configuration settings to get the most out of Performance Center. For details, see "<a href="#">Performance Center Configuration Options</a>" on page 59</li> <li>• You can set Performance Center to run Vusers and monitor servers over a firewall. For details, see "<a href="#">Working with Firewalls</a>" on page 77</li> </ul> |
| <p style="text-align: center;">Upgrade Projects</p>                             | <p>Upgrade your existing projects to the current version of Performance Center. For details, see "<a href="#">Upgrading Previously Created Projects</a>" on page 75</p>  |
| <p style="text-align: center;">Verify Installation</p>   | <ul style="list-style-type: none"> <li>• Perform a post-installation verification. For details, see "<a href="#">Post Installation Verification</a>" on page 51.</li> <li>• For installation troubleshooting details, see "<a href="#">Troubleshooting</a>" on page 109.</li> </ul>  |

## Installing HP Application Lifecycle Management

As a prerequisite to installing HP ALM Performance Center components, you must install HP Application Lifecycle Management.

**Note:** Each HP ALM Performance Center version is certified with a specific HP ALM version. Ensure you are installing Performance Center on a corresponding version of HP ALM. Corresponding versions are published on the HP download site. For more details, contact HP Software Support.

### To install HP Application Lifecycle Management:

1. Install the appropriate version of HP ALM for your system. For details refer to the HP Application Lifecycle Management Installation and Upgrade Guide.

**Note:** Ensure that ALM is installed on a certified operating system. Consult the ALM System Configurations section of the HP ALM Readme for a full list of recommended and supported operating systems for HP ALM Performance Center.

2. Set up the HP ALM client machine with the correct browser configuration. For details, refer to the HP Application Lifecycle Management Installation and Upgrade Guide.

## Installing and Configuring Performance Center Servers and Hosts

This section describes how to install and configure Performance Center servers and hosts.

**Note:** Before beginning the actual installation procedure, review the Performance Center installation flow. For details, see ["Installation Flow" on the previous page](#)

### To install a Performance Center Server or Performance Center host:

1. **Launch the Performance Center installer.**

Insert the HP ALM Performance Center installation DVD and run **setup.exe** (**<installation disk root directory>\setup.exe**).

2. **Select an installation option.**

The setup program starts and displays the installation menu page.

Select Performance Center **Server** or Performance Center **Host**.

**Note:** If you know in advance that a particular host machine is to be used as a load generator only, we recommend that you install the Standalone Load Generator for the following reasons:

- The installation requires less disk space
- Moving the Load Generator's setup files is less time consuming than moving the setup files of the Performance Center Host

For details on installing the Standalone Load Generator, see ["Installing Standalone Components \(Windows\)" on page 45](#).

To install a load generator on Linux, see [Installing HP Load Generator on Linux](#).

### 3. If necessary, install prerequisite software.

Some prerequisite software must be installed on the machine before installing the Performance Center component. If any of the prerequisite software is not already installed on the machine, the prerequisite software dialog box opens.

Click **OK** and follow the on-screen instructions to install the prerequisite software before continuing with the Performance Center component installation. You cannot continue with the Performance Center component installation unless all the prerequisite software is installed.

For a full list of prerequisite software, see ["Performance Center Prerequisite Software" on page 17](#).

**Note:** If you are prompted to restart the machine after installing the prerequisite software, you must do so before continuing with the installation. After rebooting the machine, run **setup.exe** again to continue with the installation. If the installation continues from where it left off before rebooting, we recommend starting the setup again—the installer will detect the installed prerequisites and continue with the installation.

**Note: Performance Center Server installation:** If Microsoft Internet Information Services (IIS) 7.5/8.0/8.5 is listed on this page, it is required that you close the installation, install IIS, and restart the installation.

**Note:** .NET 3.5 is a feature of the operating system. If .NET 3.5 SP1 is listed in this dialog box, close this installation, enable .NET 3.5, and restart the Performance Center installation. For more details on how to enable .NET 3.5, refer to the Microsoft documentation.

**Note:** If you intend to run Web Services Users, you must have Web Services Enhancements (WSE) 2.0 SP3 and 3.0 installed on the machines used for executing the load (Performance Center host or standalone Load Generator).

To install WSE, perform the following steps on the Performance Center host (pre or post installation):

- a. Turn on the .NET 3.5 Framework Windows feature (see [http://msdn.microsoft.com/en-us/library/hh506443\(v=vs.110\).aspx](http://msdn.microsoft.com/en-us/library/hh506443(v=vs.110).aspx)).
- b. Install WSE 2.0 SP3 and WSE 3.0 components (the components are available from the Performance Center DVD, under the **Setup\Common** folder).

To install WSE, perform the following steps on the standalone Load Generator:

- **Before Installation:** Turn on the .NET 3.5 Framework Windows feature (see [http://msdn.microsoft.com/en-us/library/hh506443\(v=vs.110\).aspx](http://msdn.microsoft.com/en-us/library/hh506443(v=vs.110).aspx)). The WSE components will be installed automatically during the Load Generator's installation.
- **During Installation:** Accept the setup program's suggestion to install .NET 3.5. The WSE components will be installed automatically during the installation.
- **After Installation:** Turn on the .NET 3.5 Framework Windows feature. (see [http://msdn.microsoft.com/en-us/library/hh506443\(v=vs.110\).aspx](http://msdn.microsoft.com/en-us/library/hh506443(v=vs.110).aspx)). Install the WSE components from the LoadRunner DVD folders, **lrunner\Common\wse20sp3** and **lrunner\Common\wse30**.

#### 4. If an earlier version of Performance Center is installed on your machine.

A dialog box opens indicating that you must first manually uninstall the previous version before installing this version. For more details on how to uninstall Performance Center, see "[Uninstalling Performance Center Server and Hosts](#)" on page 49.

**Note: Performance Center 11.52 or 11.52 Patch 1:** After uninstalling Performance Center, the Performance Center installer does not remove all of the related configuration settings. Prior to installing Performance Center 12.50, make sure to remove the configuration settings. For more details, see HP Software Self-solve knowledge base article KM01174822 (<https://softwaresupport.hp.com/group/softwaresupport/search-result/-facetsearch/document/KM01174822>).

**Note: Performance Center 11.5x:** After uninstalling Performance Center 11.5X, there is a possibility that you will not be able to launch any program from your machine. This problem can occur on a Performance Center server or host. For more details on fixing this problem, see HP Software Self-solve knowledge base article KM01178049 (<https://softwaresupport.hp.com/group/softwaresupport/search-result/-facetsearch/document/KM01178049>).

5. **Start the installation.**

The Performance Center Setup Wizard opens, displaying the Welcome page for the relevant Performance Center component. Click **Next**.

6. **Review the License agreement.**

To accept the terms of the license agreement, select **I Agree**. Click **Next**.

7. **Select a destination folder.**

Specify the location in which to install the Performance Center component. To browse possible locations, click the **Browse** button, select a location, and click **OK**.

Click **Next**.

8. **Start the installation process.**

The wizard prompts you to confirm the details and start the installation. To review or change any settings, click **Back**.

Click **Install** to start the installation. The wizard displays the installation progress.

Upon completion of the installation, the Welcome page of the Configuration wizard opens. Click **Next**.

9. **Enter the Communication Security passphrase.**

Enter the Communication Security passphrase for secure communication between the Performance Center Server and ALM. This must be identical to the passphrase defined during the ALM installation. You can view the passphrase in **Site Administration > Site Configuration** tab > **COMMUNICATION\_SECURITY\_PASSPHRASE** parameter. For more details, refer to the HP Application Lifecycle Management Administrator Guide.

Click **Next**.

10. **Create the Performance Center User (Performance Center Server only).**

Performance Center requires that a system user is created for use by the Performance Center server, hosts and the Load Generator standalone machines.

To define a system user for the Performance Center environment, enter the user and password.

**Note:**

- You can use a local or a domain user. When using a local user, if the user does not exist on the Performance Center server machine, the installer will create it.



- When using a local user, if the user name does not exist or is not in the Administrators group, it will be added to the Administrators group.
- After adding the Performance Center server to the Lab Management project, the Performance Center user will be saved to that database. Each subsequent Performance Center server or host added, will be configured with that user.
- After a Performance Center server is added to the HP ALM platform, you can use the System Identity utility (<Performance Center Server Installation directory>/bin/IdentityChangerUtil.exe) to change the user. For more details, see the *Performance Center System Administration* section in the *HP ALM Performance Center Guide*.
- Once you succeed in creating the user and configuring the server, the next time you launch the configuration wizard, this page will not be displayed.

**11. Choose the IIS Web Site (Performance Center Server only).**

Select the IIS web site to be used by the Performance Center server.

**Note:** If only one web site exists on IIS, this page will not be displayed. The installation will use the existing web site.

Click **Next**.

**12. Confirm the configuration.**

The Confirm Configuration page opens.

Click **Next**.

**13. The background configuration starts.**

The wizard displays the progress bar as it performs the configurations on the relevant component.

The wizard performs the following configurations on the relevant component:

| Configuration  | PC Server   | PC Host   |
|--|---|---|
| Copies and updates configuration files.  | Yes   | Yes   |
| Creates the Performance Center system user<br>For information about changing the system user, see the "Performance Center System Administration" section in the <i>HP ALM Performance Center Guide</i> . | Yes   | No (The user is created when adding a host to Lab Management)             |
| Configures DCOM objects.   | No (The DCOM objects are configured when adding a server to Lab Management) | No (The DCOM objects are configured when adding a host to Lab Management) |
| Installs Performance Center services: <ul style="list-style-type: none"> <li>• DataCollectionAgent</li> <li>• RemoteManagement Agent Service</li> </ul>  | Yes   | Yes   |

| Configuration   | PC Server | PC Host |
|---|-----------|---------|
| <p><b>Note:</b> For details on how to reconfigure the port used by the DataCollectionAgent service, see HP Software Self-solve knowledge base article KM01526547 (<a href="http://h20230.www2.hp.com/selfsolve/document/KM01526547">http://h20230.www2.hp.com/selfsolve/document/KM01526547</a>).</p>   |           |         |
| <p>Installs Performance Center services:</p> <ul style="list-style-type: none"> <li>Performance Center Agent Service</li> <li>Performance Center Load Testing Service</li> </ul>  | --        | Yes     |
| <p><b>Configures IIS:</b></p> <ul style="list-style-type: none"> <li>Creates virtual directories and application pools.</li> <li>Configures IIS application pools to work as 32-bit application pools.</li> <li>Sets the .NET version for the application pools to .NET 4 (v4.0.30319).</li> <li>Sets Integrated mode for the application pools.</li> <li>Sets read and write permissions for the Modules feature.</li> <li>Updates Mime type list.</li> </ul> <p><b>IIS 7.5:</b></p> <ul style="list-style-type: none"> <li>Enables Windows communication foundation.</li> <li>Adds rules: Web-ASP, Web-Asp-Net, Web-Mgmt-Compat, Web-Metabase, web-static-content, Web-Dyn-Compression.</li> <li>Disables rules: Web-Url-Auth</li> </ul> <p><b>IIS 8.0/8.5:</b></p> <ul style="list-style-type: none"> <li>Add rules: IIS-ASP, IIS-ASPNET, IIS-ASPNET45, IIS-ManagementConsole, IIS-Metabase, IIS-IIS6ManagementCompatibility, IIS-StaticConten, IIS-HttpCompressionDynamic.</li> <li>Disables rules: IIS-URLAuthorization</li> </ul> | Yes       | --      |

**14. Close the Configuration wizard.**

When the configuration is complete, the wizard confirms the configuration status.

Click **Finish** to exit the Configuration wizard.

**Note:** The configuration log files are available from:

- Server: <installation folder>\orchidtmp\Configuration\configuratonWizardLog\_pcs.txt
- Host: <installation folder>\orchidtmp\Configuration\configuratonWizardLog\_pcs.txt

**15. Complete the Performance Center installation and determine whether to install HP Network Virtualization (NV).**

The Finish page opens.

You can continue with the HP NV installation, or choose to install manually at a later time. The following options are available:

| Option                   | Description   |
|--------------------------|---|
| <b>Typical</b>           | Launches a non-interactive HP NV installation, using the default HP NV settings.                      |
| <b>Custom</b>            | Launches an interactive HP NV installation, enabling you to select which HP NV components to install. |
| <b>Do not install NV</b> | HP NV will not be installed.  |

Click **Finish** to close the Performance Center installer and proceed with your selected HP NV installation option.

**Note:**

- The Performance Center installation is complete, regardless of selected HP NV installation option.
- If you are installing HP NV on a Performance Center server, the HP NV for Performance Center Server installation will be launched.
- If you are installing HP NV on a Performance Center host, both the HP NV for Controller and the HP NV for Load Generator installations will be launched (one after the other).
- For more details on the HP NV installation, see the *HP Network Virtualization for LoadRunner and Performance Center User Guide*, available from **<Performance Center installation DVD>\AdditionalComponents\HPNV**.

**16. Add the Performance Center Server to the Trusted Sites of the client's machine browser.**

- In Internet Explorer, select **Tools > Internet Options**. The Internet Options dialog box opens.
- In the **Security** tab, select **Trusted Sites**, and click **Sites**.
- If you are not using SSL, ensure that the **Require Server verification (https:) for all sites in this zone** option is not selected.
- In the **Add this website to the zone** box, enter the Performance Center Server internal URL (`http://<ALM server name>[:port number]/qcbn`), and click **Add**.

**17. Perform additional required Performance Center configuration steps.**

- Define Performance Center servers on ALM. For more details, see ["Adding the Performance Center Server to the System" on the next page](#).
- Define Performance Center license and host keys. For more details, see ["Setting the License Keys" on page 37](#).

- c. Define Performance Center hosts. For more details, see ["Adding Performance Center Hosts" on page 38](#).

## Configuring Performance Center in Lab Management

After running the Performance Center Server installation and the Performance Center Server Configuration wizard, you must perform additional configuration steps in Lab Management before you can use the product.

This section includes:

- ["Logging In to Lab Management" below](#)
- ["Adding the Performance Center Server to the System" below](#)
- ["Setting the License Keys" on the next page](#)
- ["Adding Performance Center Hosts" on page 38](#)

### Logging In to Lab Management

All Performance Center administration tasks are done in Lab Management.

#### To log in to Lab Management:

1. Open the Web browser and type the ALM URL  
`http://<ALM server name>[:<port number>]/qcbn.`  
The ALM Options window opens.
2. Click **Lab Management**, enter the user name and password of a Site Administrator, and click **Login**.

### Adding the Performance Center Server to the System

To use the Performance Center Server, it must be defined in ALM.

**Note:** From a performance and fault tolerance perspective, it is strongly recommended to define at least two Performance Center Servers.

#### To define the Performance Center Server:

1. Log in to Lab Management. See ["Logging In to Lab Management" above](#).
2. On the Lab Management sidebar, under **Servers**, select **PC Servers**.
3. For each Performance Center Server:
  - a. In the PC Servers module, click **New PC Server** .
  - b. Enter the details of the Performance Center Server as follows:

| Field               | Description  |
|---------------------|--|
| <b>Name</b>         | The name of the Performance Center Server.   |
| <b>External URL</b> | The URL for accessing the Performance Center Server from external sources.   |
| <b>Internal URL</b> | The URL for accessing the Performance Center Server from within the system. For example, the Performance Center Server and ALM communicate with each other through this URL. |
| <b>Status</b>       | Make sure that the Performance Center Server's status is <b>Operational</b> so that ALM and other Performance Center components can access it.                               |

## Setting the License Keys

This section describes how to set Performance Center license keys.

| License Type                                       | Description  |
|--|--|
| <b>Performance Center license</b>                  | Enables you to use the product and run load tests. This license determines the number of performance tests that you can run concurrently, and the total number of Vusers available for the performance tests.  |
| <b>Performance Center Host license</b>             | Defines the Vuser protocols, monitors, and modules that are available on each host machine. This license also determines the number of Vusers available per protocol.  |
| <b>Performance Center Community License Bundle</b> | Performance Center is delivered with a free perpetual community license bundle. The bundle includes: 1 Controller allowing 1 concurrent run, 1 PC Lifecycle user, 50 permanent Vusers, and 2 NV Vusers. These Vusers are valid for all protocols except for GUI (UFT), COM/DCOM, and template protocols. The community license bundle does not include support.<br><br><div style="border-left: 2px solid green; padding-left: 10px; margin-top: 10px;"> <p><b>Note:</b> This license bundle is installed when Performance Center is first installed.</p> </div> |

### 1. Prerequisites.

Make sure the ALM license is set in the ALM Site Administration. For more information about the ALM license, see the *HP Application Lifecycle Management Administrator Guide*.

### 2. Activate your license keys.

To activate your licenses, visit the HP Software Licensing Portal (<http://www.hp.com/software/licensing>) and enter your Entitlement Order Number.

If you do not have a license, visit the HP Software Licensing Portal (<http://www.hp.com/software/licensing>) and click the **Contact Licensing Support** link.

**Note:** If you are using the community license bundle installed with Performance Center, license activation is not required.

### 3. Log in to Lab Management.

See ["Logging In to Lab Management" on page 36](#).

### 4. Set your license keys.

- a. In Lab Management, under **Performance Center** select **PC Licenses**. The PC Licenses Module Window opens. For user interface details, see the *HP ALM Lab Management Guide*.
- b. Select one of the following options:
  - i. **Add License Key**. Adds a single license key.
  - ii. **Add License from File**. Adds multiple license keys simultaneously. For user interface details, see the *HP ALM Lab Management Guide*.

## Adding Performance Center Hosts

To work with the Performance Center hosts, you must first add them to ALM. To add a host, you must first define the host's location in ALM. If the host is a load generator over a firewall, you must define the MI Listener through which the load generator will communicate with the Performance Center Server.

#### Note:

- Before adding a host, ensure that at least one Performance Center server is in an operational state.
- When adding the hosts, fields in red marked with an asterisk (\*) are mandatory, including the type of **operating system**, and the **purpose** of the host. For details, see the HP ALM Performance Center Guide.
- When adding the hosts, the system configures the Performance Center user on that machine.

#### To add hosts:

### 1. Log in to Lab Management.

See ["Logging In to Lab Management" on page 36](#).

### 2. Add the host's location.

- a. Under **Lab Resources**, select **Locations**.
- b. In the Host Locations module, click the **New Host Location**  button, and enter the host location's details.

### 3. For a host over a firewall, add the MI Listener.

- a. Under Performance Center, select **MI Listeners**.
- b. In the MI Listeners module, click the **New MI Listener**  button, and enter the MI Listener's details.

**4. Add the host.**

- a. Under **Lab Resources**, select **Hosts**.
- b. In the Hosts module, click the **New Testing Host**  button, and enter the host's details. In particular:
  - o In the Installation field, select the type of host installation: **Windows Host; Windows Standalone LG; UNIX Load Generator**.
  - o In the **Purpose** field, select a purpose for the host.

## Installing Performance Center Silently

A **silent installation** is an installation that is performed automatically, without the need for user interaction. This section describes how to perform a silent installation of Performance Center components.

Before you perform the installation, review the pre-installation information, including the system requirements, described in "Before You Install" on page 7.

This section includes:

- "Silent Installation of Prerequisite Software" below
- "Setting Up the Silent Configuration" on page 41
- "Silent Installation of Performance Center Server and Performance Center Hosts" on page 43

## Silent Installation of Prerequisite Software

Install the prerequisite software silently by running the relevant commands as follows:

| Prerequisite Software   | Command  |
|---|--|
| <b>.NET Framework 4.5.1</b>                                     | <pre>&lt;Installation_Disk_Root_Directory&gt;\Setup\Common\dotnet451\NDP451-KB2858728-x86-x64-AllOS-ENU.exe /LCID /q /norestart /c:"install /q"</pre> <p><b>Notes:</b></p> <ul style="list-style-type: none"> <li>• .Net Framework 4.5.1 replaces the .Net Framework 4.0 files. If there are any applications that are using the .Net Framework 4.0 files and are running during the installation of .Net Framework 4.5.1, you may need to restart your machine. If you are prompted to restart the machine, restart it before continuing the installation. For more information, see: <a href="http://msdn.microsoft.com/en-us/library/527997%28v=vs.110%29.aspx">http://msdn.microsoft.com/en-us/library/527997%28v=vs.110%29.aspx</a>.</li> </ul> |
| <b>Microsoft Visual C++ 2010 Service Pack 1 Redistributable</b> | <pre>&lt;Installation_Disk_Root_Directory&gt;\Setup\Common\vc2010sp1_mfc_security_update_x86\vc redistrib_x86.exe /q /norestart</pre>  |

| Prerequisite Software   | Command   |
|---|---|
| <b>Package MFC Security Update (x86)</b>  |   |
| <b>Microsoft Visual C++ 2005 Service Pack 1 Redistributable Package MFC Security Update</b>       | <Installation_Disk_Root_Directory>\Setup\Common\vc2005sp1_mfc_security_update_x86\vc redistrib_x86.exe /q:a /c:"msiexec /i vc redistrib.msi /qn" " "                        |
| <b>Microsoft Visual C++ 2005 Service Pack 1 Redistributable Package MFC Security Update (x64)</b> | <Installation_Disk_Root_Directory>\Setup\Common\vc2005sp1_mfc_security_update_x64\vc redistrib_x64.exe /q:a /c:"msiexec /i vc redistrib.msi /qn" " "                        |
| <b>Microsoft Visual C++ 2008 Service Pack 1 Redistributable Package MFC Security Update (x86)</b> | <Installation_Disk_Root_Directory>\Setup\Common\vc2008sp1_mfc_security_update_x86\vc redistrib_x86.exe /q:a /c:"msiexec /i vc_red.msi /qn" " "                              |
| <b>Microsoft Visual C++ 2008 Service Pack 1 Redistributable Package MFC Security Update (x64)</b> | <Installation_Disk_Root_Directory>\Setup\Common\vc2008sp1_mfc_security_update_x64\vc redistrib_x64.exe /q:a /c:"msiexec /i vc_red.msi /qn" " "                              |
| <b>Microsoft Visual C++ 2012 Redistributable</b>  | <Installation_Disk_Root_Directory>\Setup\Common\vc2012_redist_x86\vc redistrib_x86.exe /quiet /norestart  |
| <b>Microsoft Visual C++ 2012 Redistributable (x64)</b>  | <Installation_Disk_Root_Directory>\Setup\Common\vc2012_redist_x64\vc redistrib_x64.exe /quiet /norestart  |
| <b>Microsoft Visual C++ 2013 Redistributable</b>  | <Installation_Disk_Root_Directory>\Setup\Common\vc2013_redist_x64\vc redistrib_x64.exe /quiet /norestart  |
| <b>Windows Imaging Component (WIC)</b>  | <ul style="list-style-type: none"> <li>• <b>For 32-bit machine:</b> &lt;Installation_Disk_Root_Directory&gt;\Setup\Common\dotnet40\wic_x86_enu.exe /q /norestart</li> </ul> |



| Prerequisite Software  | Command   |
|--|---|
|  | <ul style="list-style-type: none"> <li>• <b>For 64-bit machine:</b> &lt;Installation_Disk_Root_Directory&gt;\Setup\Common\dotnet40\wic_x64_enu.exe /q /norestart</li> </ul>   |
| <b>Microsoft Data Access Components (MDAC) 2.8 SP1 (or later)</b>                          | <Installation_Disk_Root_Directory>\Setup<environment>\prerequisites\mdac28\mdac28.exe /q:A /C:"setup /QNT"  |
| <b>Microsoft Core XML Services (MSXML) 6.0</b>   | <p><b>For x86:</b> msexec /log c:\msxml.log /quiet /I &lt;Installation_Disk_Root_Directory&gt;\Common\msxml6\msxml6.msi</p> <p><b>For x64:</b> msexec /log c:\msxml.log /quiet /I &lt;Installation_Disk_Root_Directory&gt;\Common\msxml6\msxml6_x64.msi</p> <p><b>For ia64:</b> msexec /log c:\msxml.log /quiet /I &lt;Installation_Disk_Root_Directory&gt;\Common\msxml6\msxml6_ia64.msi</p>   |
| <b>Microsoft Windows Installer 3.1</b>   | <Installation_Disk_Root_Directory>\Setup\Common\msi31\WindowsInstaller-KB893803-v2-x86.exe /q /norestart  |
| <b>Java 2 Runtime Environment, Standard Edition 1.7.0_25 (x86)</b>                         | <Installation_Disk_Root_Directory>\Setup\Common\Java_7\PassiveModeInstallationWrapper.exe/s (The Java installation is performed by a wrapper that provides support for a silent and non-interactive installation. This tool launches the default java installation file from <Installation_Disk_Root_Directory>\Setup\Common\Java_7\jre-7u25-windows-i586.exe).   |
| <b>Internet Information Services (IIS)</b><br><b>Note: Performance Center Server only!</b> | <p><b>Use the following to install IIS7.5/IIS8/IIS8.5:</b></p> <pre>start /w pkgmgr /iu:IIS-WebServerRole;IIS-WebServer;IIS-ASP;IIS-StaticContent;IIS-IIS6ManagementCompatibility;WAS-WindowsActivationService;WAS-ProcessModel;WAS-NetFxEnvironment;WAS-ConfigurationAPI</pre> <p>For more details, see:<br/><a href="http://learn.iis.net/page.aspx/136/install-typical-iis-workloads/">http://learn.iis.net/page.aspx/136/install-typical-iis-workloads/</a></p> |

## Setting Up the Silent Configuration

This section describes how to customize the file used for silent configuration of the Performance Center. The **UserInput.xml** file—installed with Performance Center—contains parameters for the Performance Center Server and Performance Center Host configurations.

You can customize the parameters in the **UserInput.xml** file. You then instruct the Installer to use the customized file for the silent configuration input.

### To configure the properties in the UserInput.xml file:

1. Copy the **UserInput.xml** file from the installation DVD (**..\Setup\Install\Server\TARGETDIR\dat\Setup\PCS\LTSS\Xml\**) to another location.
2. Open the copy of the file and enter a user-defined value for the following property:

| Property                     | Description  |
|------------------------------|--|
| <b>LW_CRYPT0_INIT_STRING</b> | This passphrase must be identical to the passphrase defined during the ALM installation. |

**3. For Performance Center Server only:**

| Property                 | Description   |
|--------------------------|---|
| <b>IIS_WEB_SITE_NAME</b> | <p>Choose the IIS web site that will be used to host the Performance Center server services.</p> <p><b>Note:</b></p> <ul style="list-style-type: none"> <li>The web site must exist prior to running the configuration.</li> <li>The value is optional. If no web site is specified and there is more than one defined on your machine, the configuration will use the first one (the one with the smallest ID value).</li> </ul>   |
| <b>SystemUserName</b>    | <p>Choose the name of the user that will be configured as the Performance Center Windows system user.</p> <p><b>Note:</b></p> <p>You can use a local or a domain user:</p> <ul style="list-style-type: none"> <li>If you are using a local user, the user will be added to the Administrator group.</li> <li>If you are using a domain user, the value for this property should be in the form of &lt;domain\user&gt;. Make sure the machine and the user are part of the same domain and that the user exists on the machine.</li> <li>If you do not provide a user name, the system will use the default user name ('IUSR_METRO').</li> <li>A user name cannot include the following characters [ ] :   &lt; + &gt; = ; , ? * @</li> <li>If the supplied user's details are invalid (for example, the user name contains invalid characters, or the domain user does not exist), the system will use the default user name ('IUSR_METRO') instead.</li> </ul> <p>For more details on defining a user, see <a href="#">"Installing and Configuring Performance Center Servers and Hosts" on page 29</a>.</p> |
| <b>SystemUserPwd</b>     | <p>Choose the password for the Performance Center Windows system user.</p> <p><b>Note:</b></p> <ul style="list-style-type: none"> <li>If the installer uses the default user (for example, when the value for property 'SystemUserName' is empty), the password property will be ignored and the installer will use the default password ('P3rfoRm@1nce').</li> <li>The password cannot be empty. If this field is left empty, the system will use the default password ('P3rfoRm@1nce').</li> <li>If using an existing user for the 'SystemUserName' property, the password must match the password used by the existing user.</li> </ul>  |

4. Save the **UserInput.xml** file.

5. Specify the location of the saved file when running the silent installation command.

## Silent Installation of Performance Center Server and Performance Center Hosts

This section describes how to run the silent installation of the Performance Center Server and Performance Center hosts on a Windows platform.

The silent installation is followed by the silent configuration which calls the **UserInput.xml** file for configuration parameters. You can customize the parameters in this file for the Performance Center Server configuration. For details, see ["Setting Up the Silent Configuration" on page 41](#).

**To perform a silent installation of Performance Center, use one of the following options:**

- **Option 1: Install the prerequisite software and the Performance Center component.**
  - a. Install the prerequisite software. For details, see ["Silent Installation of Prerequisite Software" on page 39](#).

**Note:** If you are prompted to restart the computer after installing the prerequisite software, you must do so before continuing with the installation.

- b. After you have installed all the prerequisite software, install the Performance Center component by running the appropriate command from the command line.

**Performance Center Server:**

|  |   |
|--|---|
| <b>Silent installation with default properties</b>       | <pre>msiexec /i &lt;Installation_Disk_Root_Directory&gt;\Setup\Install\Server\PCServer.msi INSTALLDIR="&lt;Target Installation Directory&gt;" NVINSTALL=Y NV_REBOOT=Y /qnb /l*vx "&lt;Path to log file&gt;"</pre>   |
| <b>Silent installation with customized UserInput.xml</b> | <pre>msiexec /i &lt;Installation_Disk_Root_Directory&gt;\Setup\Install\Server\PCServer.msi USER_CONFIG_FILE_PATH="&lt;Full path to UserInput file&gt;" INSTALLDIR="&lt;Target Installation Directory&gt;" NVINSTALL=Y NV_REBOOT=Y /qnb /l*vx "&lt;Path to log file&gt;"</pre> |

Where **<Full path to UserInput file>** is the path to your customized UserInput.xml file, **<Target Installation Directory>** is the directory in which to install the Performance Center Server, and **<Path to log file>** is full path to the installation log file.

**NVINSTALL** indicates whether to launch the NV installation in silent mode, once the Performance Center installation is done (by default, NV is not installed in silent mode).

**NV\_REBOOT** indicates whether to automatically restart the machine after the NV installation is done (by default, the restart is disabled). Setting this property without installing NV will not have any affect.

**Note:** Restarting the machine is required in order for NV to function properly.

**Performance Center Host:**

|                   |  |
|-------------------|--|
| <b>For 32-bit</b> | msiexec /i <Installation_Disk_Root_Directory>\Setup\Install\Host\PCHost_32Bit.msi<br>USER_CONFIG_FILE_PATH="<Full path to UserInput file>" [optional installer properties - see list below] /qn /l*v " <Path to log file>" |
| <b>For 64-bit</b> | msiexec /i <Installation_Disk_Root_Directory>\Setup\Install\Host\PCHost_64Bit.msi<br>USER_CONFIG_FILE_PATH="<Full path to UserInput file>" [optional installer properties - see list below] /qn /l*v " <Path to log file>" |

Where **<Full path to UserInput file>** is the path to your customized UserInput.xml file, **<Target Installation Directory>** is the directory in which you want to install the Performance Center host, and **<Path to log file>** is full path to installation log file.

**NVINSTALL** indicates whether to launch the NV installation in silent mode, once the Performance Center installation is done (by default, NV is not installed in silent mode).

**NV\_REBOOT** indicates whether to automatically restart the machine after the NV installation is done (by default, the restart is disabled). Setting this property without installing NV will not have any affect.

**Note:** Restarting the machine is required in order for NV to function properly.

- **Option 2: Install the prerequisite softwares together with the Performance Center components.** You can also install in silent mode using the **setup.exe** file from the DVD. This enables you to install the prerequisites in silent mode automatically before running the MSI installation in silent mode. Using this option also invokes the correct MSI file depending on the operating system platform.

**Server installation:**

```
<Installation_Disk_Root_Directory>\Setup\En\setup_server.exe /s USER_CONFIG_FILE_PATH="<Full path to UserInput file>" INSTALLDIR="<Target Installation Directory>" NVINSTALL=Y NV_REBOOT=Y
```

**Host installation:**

```
<Installation_Disk_Root_Directory>\Setup\En\setup_host.exe /s INSTALLDIR="<Target Installation Directory>" USER_CONFIG_FILE_PATH="<Full path to UserInput file>" NVINSTALL=Y NV_REBOOT=Y
```

Where **<Full path to UserInput file>** is the path to your customized UserInput.xml file and **<Target Installation Directory>** is the directory in which to install the Performance Center Server or Host.

When using the **setup.exe** file, the installation log will be create under the user's temp directory.

**Host installation:** %temp%\PCHost.log.

**Server installation:** %temp%\PCServer.log.

Where **<Full path to UserInput file>** is the path to your customized UserInput.xml file, **<Target Installation Directory>** is the directory in which you want to install the Performance Center host, and **<Path to log file>** is full path to installation log file.

**NVINSTALL** indicates whether to launch the NV installation in silent mode, once the Performance Center installation is done (by default, NV is not installed in silent mode).

**NV\_REBOOT** indicates whether to automatically restart the machine after the NV installation is done (by default, the restart is disabled). Setting this property without installing NV will not have any affect.

**Note:** Restarting the machine is required in order for NV to function properly.

## Installing Standalone Components (Windows)

You can install standalone components that provide advanced features for working with HP ALM Performance Center.

To install a load generator on Linux, see [Installing HP Load Generator on Linux](#).

**Note:** For all standalone applications, you must first manually install the prerequisite applications. For more details, see ["Silent Installation of Prerequisite Software" on page 39](#)

This section includes:

- ["Available Standalone Components for Windows" below](#)
- [" Installing Standalone Components" on the next page](#)
- ["Silent Installation of the Standalone Applications" on the next page](#)

## Available Standalone Components for Windows

The following standalone components are available. To install these components, see [" Installing Standalone Components" on the next page](#).

| Component                | Description  |
|--------------------------|--|
| <b>HP Load Generator</b> | <p>Instead of installing a Performance Center Host and then configuring it as a load generator, you can install a standalone version of the load generator. This host can behave only as a load generator, unlike the Performance Center host, which can also be configured as a Controller or data processor. You can use a local or a cloud-based machine to host your load generator, with Amazon AWS or HP Cloud Computing.</p> <p><b>Note:</b> If you know in advance that a particular host machine is to be used as a load generator only, we recommend that you install the standalone Load Generator for the following reasons:</p> <ul style="list-style-type: none"> <li>• The installation requires less disk space</li> <li>• Moving the Load Generator's setup files is less time consuming than moving the setup files of the Performance Center Host.</li> </ul> |

| Component                          | Description  |
|------------------------------------|--|
| <b>HP Virtual User Generator</b>   | HP Virtual User Generator (VuGen) generates virtual users, or Vusers, by recording actions that typical end-users would perform on your application. VuGen records your actions into automated Vuser scripts which form the foundation of your performance tests.                        |
| <b>HP LoadRunner Analysis</b>      | HP Analysis provides graphs and reports with in-depth performance analysis information. Using these graphs and reports, you can pinpoint and identify the bottlenecks in your application and determine what changes need to be made to your system in order to improve its performance. |
| <b>MI Listener</b>                 | The MI Listener is one of the components needed to run Vusers and monitor applications over a firewall. To install, run <b>SetupMIListener.exe</b> . For more information about firewalls in Performance Center, see <a href="#">"Working with Firewalls" on page 77</a> .               |
| <b>Monitor Over Firewall Agent</b> | Used to monitor servers that are located over a firewall. For more information about firewalls in Performance Center, see <a href="#">"Working with Firewalls" on page 77</a> .  |
| <b>Snapshot Viewer</b>             | Enables you to view snapshot-on-error pages captured from Web Vusers during performance test runs. The viewer displays snapshots from files with .SOE and .INF extensions. A Snapshot on Error (.SOE) file is a zipped file containing one or more snapshots in .INF format.             |

## Installing Standalone Components

This section describes the installation process for standalone components.

### To install any of the standalone components:

1. Insert the HP ALM Performance Center Additional Components installation disk (DVD 2) and run the setup (<installation disk root directory>\setup.exe). The setup program displays the installation menu page.
2. Select one of the following options: **Load Generator**, **Virtual User Generator**, **Analysis**, **MI Listener**, or **Monitor Over Firewall**. For more details, see the *LoadRunner Installation Guide*.
3. **MI Listener/Monitor Over Firewall installations only:** Follow the instructions in the installation wizard. After installation, the configuration wizard opens, requesting the name of the product you are working with. Select **Performance Center**.

## Silent Installation of the Standalone Applications

This section describes how to perform a silent installation of the standalone applications.

**Note:** For instructions on installing the HP Load Generator silently on Linux, see the *LoadRunner Installation Guide*.

Choose one of the following options:

### Option 1: Install the prerequisite software and the application separately

1. Install required prerequisite software. For details, see "[Silent Installation of Prerequisite Software](#)" on page 39.
2. Extract the Load Generator installation files to a local directory:
  - a. From the DVD labeled **HP ALM Performance Center 12.50 - Standalone Applications** navigate to **Additional Components > Applications** and choose an application.
  - b. In the **Save files in folder** box, enter the name of the local directory where you want to save the installation files.
3. Run one of the following commands from the command line:

```
Load Generator: msixec /i "<Installation_Folder>\HP_LoadGenerator.msi" /qb /1*vix "<Path to log file>" IS_RUNAS_SERVICE=1 START_LGA="1"
```

```
VuGen Standalone: msixec /i "<Installation_Folder>\HP_VuGen.msi" /qb /1*vix "<Path to log file>"
```

```
Analysis Standalone: msixec /i "<Installation_Folder>\HP_Analysis.msi" /qb /1*vix "<Path to log file>"
```

where **<Installation\_Folder>** is the local directory where you saved the installation files, and **<Path to log file>** is the full path to the installation log file.

**Note:** You can install the HP Load Generator component on a Linux platform to run virtual users. The Linux virtual users interact with the Controller, installed on a Windows machine. For more information on installing the HP Load Generator on Linux, see the *LoadRunner Installation Guide*.

#### Option 2: Install the prerequisite software and the application together

1. From the DVD labeled **HP ALM Performance Center 12.50 - Standalone Applications** navigate to **Additional Components > Applications** and choose an application.
2. Run one of the following commands from the command line:

```
Load Generator: SetupLoadGenerator.exe /s /a IS_RUNAS_SERVICE=1 START_LGA="1" /s
```

**VuGen Standalone:** SetupVuGen.exe /s /a /s

**Analysis Standalone:** SetupAnalysis.exe /s /a /s

## Installing Additional Components

You can install additional components that provide advanced features for working with Performance Center. You install these components from the **Additional Components** directory, located in the root directory of the installation disk. The following components are available:

| Component   | Description   |
|---|---|
| <b>Agent for Citrix Server</b>                            | Installs an optional component on the server machine that enhances VuGen's capabilities in identifying Citrix client objects. (Available for 32-bit)  |
| <b>Agent for Microsoft Terminal Server.</b>               | Used for extended RDP protocol record-replay. This component runs on the server side, and is used to create and run enhanced RDP scripts.   |
| <b>Applications</b>                                       | This folder contains the setup files for following standalone applications: Analysis, Virtual User Generator (VuGen), Load Generator, MI Listener, Monitors Over Firewall, PAL Data Set Creator, and Snapshot Viewer.<br><br>Run the relevant application's setup program and follow the wizard's instructions. For more information, see " <a href="#">Applications</a> " on page 9. |
| <b>Assembly Crawler for Analysis API</b>                  | Installs a command-line utility to build a .NET configuration file for a LoadRunner Analysis API application. For more information, refer to the Analysis API Reference.  |
| <b>HP Performance Validation SDK</b>                      | Provides the tools to create a custom protocol for running performance tests on a previously unsupported application. For more information, see the <i>HP Performance Validation SDK Developer's Guide</i> .  |
| <b>IDE Add-ins</b>  | Installs add-ins for Visual Studio or Eclipse, enabling you to create NUnit or JUnit tests in your standard development environment using the LoadRunner API.   |
| <b>LRTCPDump</b>  | A trace file containing a log of all TCP traffic over the network. Using a sniffer application, you obtain a dump of all of the network traffic. The sniffer captures all of the events on the network and saves them to a capture file.  |
| <b>mobileRemoteAgent</b>                                  | Starts the Mongoose Web server to provide mobile functionality.   |
| <b>Monitor Probe for Microsoft COM+ Server Components</b> | Configures the server machine for COM+ monitoring.  |
| <b>SAP Tools</b>  | The following SAP tools are available:  |



| Component                   | Description  |
|-----------------------------|--|
|                             | <ul style="list-style-type: none"> <li>• <b>SAPGUI Spy.</b> Examines the hierarchy of GUI Scripting objects, on open windows of SAPGUI Client for Windows.</li> <li>• <b>SAPGUI Verify Scripting.</b> Verifies that the SAPGUI Scripting API is enabled.</li> </ul>  |
| <b>Virtual Table Server</b> | <p>Virtual Table Server (VTS) is a web-based application that works with Vuser scripts. VTS offers an alternative to standard parameterization.</p> <p>Two versions of VTS are available: 32-bit and 64-bit. You can install 32-bit VTS on both 32-bit and 64-bit operating systems; 64-bit VTS can be installed only on 64-bit operating systems.</p> |

## Uninstalling Performance Center Server and Hosts

You can uninstall Performance Center servers and hosts using the Performance Center Setup Wizard or using the silent commands.

**Note: Performance Center 11.52 or 11.52 Patch 1:** After uninstalling Performance Center, the Performance Center installer does not remove all of the related configuration settings. Prior to installing Performance Center 12.50, make sure to remove the configuration settings. For more details, see HP Software Self-solve knowledge base article KM01174822

<https://softwaresupport.hp.com/group/softwaresupport/search-result/-/facetsearch/document/KM01174822>).

**Note: Performance Center 11.5x:** After uninstalling Performance Center 11.5X, there is a possibility that you will not be able to launch any program from your machine. This problem can occur on a Performance Center server or host. For more details on fixing this problem, see HP Software Self-solve knowledge base article KM01178049

<https://softwaresupport.hp.com/group/softwaresupport/search-result/-/facetsearch/document/KM01178049>).

### To uninstall Performance Center components using the setup wizard:

1. From the Windows Control Panel, open the Add/Remove Programs dialog box.
2. From the list of currently installed programs, select **HP Performance Center** and click **Remove**.
3. Follow the instructions in the wizard to complete the uninstall process.

### To uninstall Performance Center components silently:

Run the applicable command from the command line.

- **Performance Center Server:**

```
msiexec.exe/uninstall "<Installation_Disk_Root_
Directory>\Setup\Install\Server\PCServer.msi" /qnb
```

- **Performance Center Host:**

```
msiexec.exe/uninstall "<Installation_Disk_Root_Directory>\Setup\Install\Host\PCHost_x64.msi" /qnb
```

Or

```
msiexec.exe/uninstall "<Installation_Disk_Root_Directory>\Setup\Install\Host\PCHost_x86" /qnb
```

**Note: HP NV:** When uninstalling Performance Center, the NV components installed during the Performance Center installation will be automatically uninstalled.

## Uninstalling the HP Load Generator from Linux

You can use the Load Generator Setup Wizard to uninstall the HP Load Generator. For more information, see the *LoadRunner Installation Guide*.

# Chapter 3: Post Installation Verification

This section describes how to verify that the installation of the Performance Center Server and hosts was successful. The environment for this process should be a staging environment, including a Performance Center Server and two to three Performance Center hosts.

**Note:** You can run a full validation on your ALM-Performance Center system from Lab Management, in the System Health module's System Check tab. For more details, see the *HP ALM Lab Management Guide*.

This chapter includes:

- [Administrator Workflow](#) ..... 52
- [Performance Tester Workflow](#) ..... 53

## Administrator Workflow

This section describes the workflow for the Performance Center administrator.

1. **Log on to Site Administration.**
  - a. Open the Web browser and type the ALM URL  
`http://<ALM platform server>[:port number]/qcbn.`  
The ALM Options window opens.
  - b. Click Site Administration, enter the user name and password of a Site Administrator, and click **Login**.
2. **Create a project administrator user.**
  - a. In Site Administration, select the **Site Users** tab and click **New User**. The New User dialog box opens.
  - b. Enter the details of the project administrator user, and click **OK**.
  - c. Select the user, click **Password**, enter the password, and click **OK**.
3. **Create a domain.**
  - a. In Site Administration, select the **Site Projects** tab and click **Create Domain**. The Create Domain dialog box opens.
  - b. Enter a name for the new domain, and click **OK**.
4. **Create a new project.**

In the **Site Projects** tab, select the domain you just created, and click **Create Project**. Follow the steps to create the project. When prompted:

  - a. Add the project administrator user you created above to the **Selected Project Administrators** list.
  - b. **HP ALM (consolidated license):** Select **ALM Lab Extension**.
5. **Assign more project administrators to the project - optional.**
  - a. Click the **Site Projects** tab.
  - b. In the Projects list on the left, select the project you created.
  - c. In the right pane, click the **Project Users** tab.
  - d. Add another user, and select **Project Administrator**.
6. **Log on to Lab Management.**
  - a. Open the Web browser and type the ALM URL  
`http://<ALM platform server>[:port number]/qcbn.`  
The ALM Options window opens.
  - b. Click **Lab Management**, enter the user name and password of a Site Administrator, and click **Login**.

### 7. Verify the Performance Center configuration.

On the Lab Management sidebar:

- Under **Servers**, select **PC Servers** and verify that the Performance Center Server is listed.
- Under Performance Center, select **PC Licenses** and verify the license details.

For more details, see "[Configuring Performance Center in Lab Management](#)" on page 36.



### 8. Define additional hosts for the staging environment.

For the staging environment, you should have two to three Performance Center hosts, where at least one host purpose is configured as Controller, and at least one host purpose is configured as Load Generator.

**Note:** When adding hosts, fields in red marked with an asterisk (\*) are mandatory. Make sure to include the operating system type, and the purpose of the host. For more details, see the HP ALM Lab Management Guide.

- a. In Lab Management, under **Lab Resources**, select **Hosts**.
- b. Click the **New Testing Host**  button. The New Host dialog box opens, enabling you to define the host details.

### 9. Create host pools.

- a. In Lab Management, under **Lab Resources**, select **Pools**.
- b. Click the **New Host Pool**  button. The New Host Pool dialog box opens, enabling you to define a new host pool.
- c. In the Host Pools module, right-click the new host pool and select **Host Pools Details**.
- d. In the Host Pool Details dialog box, select **Linked Hosts**, and click the **Add Hosts to Pool**  button.
- e. In the Add Hosts to Pools dialog box, select the hosts to add to the pool, and click **Add**. The hosts are added to the pool.

### 10. Define project settings.

- a. In Lab Management, select **Project Settings**.
- b. Right-click the project and select **Project Settings Details**. In the Project Settings Details dialog box, define the project's settings. In particular, set the Vuser limit, Host limit, and Concurrent run limit. Also, select the host pool you created above for the project.

## Performance Tester Workflow

This section describes the workflow for the Performance Center tester.



**Note:** Some steps in this section can also be done from the My Performance Center. This includes procedures such as creating performance tests, uploading Vuser scripts, designing performance tests, creating test plan trees, adding tests to test sets, and running tests. For more details, see the HP ALM Performance Center Guide.

**1. Log on to a Performance Center project.**

Log on to the project you created in the administration workflow with the user credentials you created.

**2. Create a monitor profile.**



**Note:** The monitor profile is selected for a performance test when you design the test.

- a. On the My Performance Center navigation bar, select **Resources > Test Resources**.
  - b. Create a folder for the monitor profile.
  - c. Select the folder, and click the **New Monitor Profile**  button. The Create New Monitor Profile dialog box, enabling you to add a new monitor profile.
  - d. Enter the required information and click **OK** to add the monitor profile to the folder.
  - e. In the Monitor Profile page, click the **Add Monitor** button . In the Add New Monitor page that opens, select the monitor that you want to run. The relevant Edit Monitor dialog box opens.
  - f. Enter the details of the server to be monitored, and select the counters that you want to monitor.
  - g. Click **Save**. The monitor is added to your monitor profile.
- 3. Create a topology.**

**Note:** The topology is selected for a performance test when you design the test.

You can create a topology that graphically displays the logical components that make up the application under test (AUT) and the relationships between the components.

This provides a useful method for managing your inventory of AUT hosts and enables topology-oriented monitoring and analysis.

- a. On the My Performance Center navigation bar, select **Resources > Topologies**.
- b. To create a topology folder, click the **New Folder**  button, and enter the folder name.
- c. Click the **New Topology**  button and enter the topology details. To add SiteScope monitors to the topology, specify the SiteScope server details.  
The Topology Designer window opens.

- d. From the palette on the left, select relevant nodes representing the components in your AUT and drag them onto the Topology canvas.
- e. To connect two components, click one component (ensure that it is not selected) and drag the cursor to the other component.
- f. (Optional) Define your AUT hosts.

On the Topology Designer window, click **AUT Hosts**. Click **Add New AUT Host**  to define the machines hosting your AUT.

**Note:** An AUT host pool is created automatically as soon as you add an AUT host.

- g. (Optional) Configure the component properties.

Select a component and, in the **Properties** pane in the top right corner of the Topology Designer, enter the relevant properties for that component. For successful integration with SiteScope, ensure that you select the relevant AUT host, and that all of the relevant properties are accurate.

Repeat this procedure for each of the relevant components.

- h. Configure monitors on the components.

You can configure groups of monitors for the components on AUT hosts. Ensure that the AUT host details are accurate for each relevant component.

- o To deploy relevant monitors on specific components on your canvas, select the components, right-click the selection, and select **Deploy Monitor Templates**. Monitor groups are created in SiteScope for each selected component, and each group is automatically configured with relevant system-defined monitors.
- o To configure monitors for a component manually in SiteScope, right-click the component and select **Configure Monitors**. For more details about configuring monitors in SiteScope, see the *HP SiteScope User Guide*.



**Note:** The AUT host defined in a component's properties is passed to SiteScope as a remote host and is inserted as the default monitored server for all monitors created for this component.

- i. Save the topology.

#### 4. Upload Vuser scripts.

**Note:** You select scripts for a performance test when you design the test.

- a. Make sure the script is saved locally and is zipped.
- b. On the My Performance Center navigation bar, select **Test Management > Test Plan**.

- c. Create a script folder. Select **Subject**. Click the **New Folder**  button, and specify a name for the folder. Click **OK**.
  - d. Select the folder. On the module toolbar, click the **Upload Script**  button. The Upload VuGen Scripts dialog box opens.
  - e. In the Upload Scripts dialog box, in the **Select Folder** box, select the folder you created in the previous step as the location to save the script.
  - f. In the **Select Scripts** fields, click **Select** to navigate to the location of the scripts. You can upload five scripts at a time.
  - g. Click **Upload**.
5. **Create a performance test.**
- a. On the My Performance Center navigation bar, select **Test Management > Test Plan**.
  - b. Select **Subject**. Click the **New Folder** button, and specify a name for the folder. Click **OK** to add the folder.
  - c. Select the folder, and click the **New Test**  button. The Create New Performance Test dialog box opens.
  - d. Enter the test name and click **OK**. The Performance Test Designer opens.
6. **Design the performance test.**

The following steps guide you through designing a performance test with a basic workload, using default settings. Some options and steps may vary if you change any of the default settings.

a. **Open the Performance Test Designer.**

On the My Performance Center navigation bar, select **Test Management > Test Plan**. In the tree, right-click the test that you created above, and select **Edit Test**. The Performance Test Designer window opens, displaying the Groups & Workload view.

b. **Select a workload.**

In the Workload Types dialog box, select the default workload type: Basic Schedule, by test, by number.

c. **Assign a Controller.**

By default, a dedicated Automatch Controller is selected.

**Note:** A dedicated Automatch Controller functions as a Controller only, and cannot perform the functions associated with other hosts, such as load generators or data processors.

d. **Add Vuser scripts.**

Click the **Select Scripts** button. The scripts you uploaded are displayed in the Scripts Tree in the right pane. Select scripts for the test, and click the left arrow button to add them to the test. A Vuser group is created for each script, with a default of 10 Vusers.



e. **Distribute load generators among the Vuser groups.**

In the **LG Distribution** box, select **Assign all to each group**, and in the **LG** box, enter the desired number of load generators to be assigned to each group—enter **1**.

f. **Define a test schedule.**

In the Global Scheduler pane, keep the default scheduler actions or modify them as desired. The available scheduler actions are:

| Action              | Description  |
|---------------------|--|
| <b>Initialize</b>   | Instructs the Scheduler to prepare the Vusers so that they are ready to run.                     |
| <b>Start Vusers</b> | Instructs the Scheduler to start running the Vusers.   |
| <b>Duration</b>     | Instructs the Scheduler to continue running the current action for the specified amount of time. |
| <b>Stop Vusers</b>  | Instructs the Scheduler to stop the running Vusers.  |



**Tip:** The schedule graph on the right of the Scheduler pane provides a graphical representation of the schedule actions defined in the Actions grid.

g. **Select monitor profiles.**

Click **Monitors** and click **Add Monitor Profile**. The defined monitor profiles are displayed in the Monitor Profiles Tree in the right pane. Select monitor profiles for the test, and click the left arrow button to add them to the Monitor Profiles grid.

h. **Select a topology.**

Click **Topology** and click **Select Topology**. The topology you created earlier appears in the Topologies Tree in the right pane. Select the topology, and click the left arrow button to select it for the test.

i. **Save the test.**

When you are finished designing the test, click **Save**. A message is displayed in the bottom-left corner of the Performance Test Designer window. Verify that the test was saved without errors and is valid.

7. **Add the test to a test set.**

- On the My Performance Center navigation bar, select **Test Management > Test Lab**.
- Click the  **Manage Test Sets** button, and specify a name for the Test Set folder. Click **OK**.
- Select the folder you created above, and click the **New Test Set \*** button. The Create New Performance Test Set dialog box opens.
- Enter the test set name. Click **OK**. The test name is added to the tree. Select the test set and click **OK**.
- Assign the performance test to the test set.

- f. Click the  **Assign Test** button. The Assign Test to Test Set dialog box opens.
        - g. Select your test and click **OK**.
8. **Reserve a timeslot for the test.**

Decide on a time in the future to run the test, and reserve a timeslot to ensure that the required resources are available.

  - a. On the My Performance Center navigation bar, select **Resources > Timeslots**.
  - b. Click the **New Timeslot**  button. The Add New Timeslot dialog box opens.
  - c. Define the following information:
    - o **Start.** Choose **Manually** as the method for executing tests. The timeslot reservation reserves testing resources only.
    - o **Name.** Enter a name for the timeslot.
    - o **Select a test instance.** Navigate to the test set you created above, and select the test to link it to the timeslot. The number of Vusers and hosts that were defined as part of the test design process are automatically displayed.
    - o **Duration.** Set the start time, and enter a duration for the test.
    - o **Post-Run.** Select **Collate and Analyze**.
  - d. (Optional) Click **Add Automatch Host** or **Add Specific Host** to reserve additional load generators for the timeslot. There must be a Controller and at least one load generator requested for the timeslot.
  - e. Click **Calculate Availability**. The system checks the availability of the requested resources. The results of this calculation are displayed in the Timeslot Status tab and graphically on the resource availability timeline.

If the timeslot cannot be reserved, consider the reasons displayed in the **Timeslot Status** tab when reselecting your resources.
  - f. If the requested resources are available, click **Submit** to save the timeslot.
9. **Run the test.**
  - a. On the My Performance Center navigation bar, select **Test Management > Test Plan**.
  - b. Select the test in the tree, and click **Run Test**. The Run Test dialog box opens.
  - c. Click **Reserved**. Select a timeslot in the grid and click **Run**.

The Initializing Run page displays the performance test initialization steps performed by Performance Center, and the status for each step. If each step is completed successfully, the performance test starts running and the Performance Test Run page opens. The Test Run page enables you to manage and monitor the test as it runs.
10. **Track existing performance test runs.**

On the My Performance Center navigation bar, select **Test Management > Test Lab**. In the Test Runs pane, you can track the state of existing test runs, as well as perform other post-run actions, such as collate, analyze, recalculate the SLA, and generate and view HTML reports.

# Chapter 4: Performance Center Configuration Options

The Performance Center system comes with default configuration settings. These settings enable you to use Performance Center for its intended purpose. This chapter describes additional tuning and configuration to help you get the most out of your Performance Center system.

**Note:** Not all the procedures in this chapter are suitable for all usage scenarios. You should assess which procedures are suitable to your system's needs.

This chapter includes:

- [Configuring IIS on Performance Center Machines to Use SSL](#) ..... 60
- [Working with Performance Center Agent](#) .....66
- [Recommended Configuration for HP Load Generator \(Linux\)](#) ..... 67
- [Establishing Connectivity with Oracle](#) .....67
- [Establishing Connectivity with Oracle using SSL](#) .....68
- [Enabling Downloading Standalone Applications](#) .....69
- [Enabling MS-SQL Windows Authentication](#) .....70
- [Configuring SSL for Load Generators](#) ..... 71

## Configuring IIS on Performance Center Machines to Use SSL

IIS (Microsoft Internet Information Server) is a prerequisite software for the Performance Center Servers. You can configure the IIS Performance Center virtual directories (Performance Center server and host) to use SSL (Secure Socket Layer).

This section describes how to configure IIS Performance Center virtual directories to use SSL.

### Before You Configure IIS

IIS uses port 443 to work over SSL. However, certain Performance Center components may also be configured to use this port. Therefore, you need to ensure that port 443 is available for use by IIS. Make sure to configure the Performance Center components to use a port other than 443.

**Note:** The **Remote Management agent** may be configured to use port 443.

### Changing the Port on the Remote Management Agent

Using the Network and Security Manager tool, you can change the port being used by the Remote Management agent for over firewall communication. For more information on the Network and Security Manager tool, see the *HP LoadRunner User Guide*.

### Configuring IIS to Work Over SSL

This section describes the basic steps involved in setting up IIS on the Performance Center Server machine to use SSL.

#### **To configure IIS to use SSL on the Performance Center Server machine:**

1. Obtain a server certificate issued to the fully qualified domain name of your Performance Center server.
2. Configure IIS to work over with SSL. For information, see <http://support.microsoft.com/>
3. If you are using a secure connection for the internal URL of the Performance Center server, you need to establish trust to the Certificate Authority (CA) that issued your Performance Center server certificate.

**Note:** Internal URL is defined when the Performance Center server is configured in ALM.

This trust must be established on the ALM server and on each Performance Center host.

**To configure trust on the ALM server:**

- a. Obtain the certificate of the root and any intermediate Certificate Authority that issued the Performance Center server certificate.
- b. On the ALM server, go to the ALM java bin.

For example, C:\Program Files\HP\ALM\java\jre\bin

- c. Import this certificate into the ALM java truststore by using a keytool command.

For example, `.\keytool -import -trustcacerts -alias myCA -file <path to ca.cer> -keystore "c:\Program Files\HP\ALM\java\jre\lib\security\cacerts"`

- d. Replace the path to the file for your root certificate authority certificate.

**Note:** **Changeit** is the default password to the java truststore. Replace as needed.

- e. If your access is denied, run CMD as an administrator.
- f. Restart ALM.

For Performance Center host, the root certificate of the CA should appear in the Microsoft Management Console under **Certificates (Local Computer) > Trusted Root Certification Authorities**.

## Configuring Performance Center to Support SSL

The following section describes how to enable SSL to ensure secure communication on Performance Center. You can configure both the Performance Center server and host.

To configure secure communication on a Performance Center server for incoming requests from the ALM server and the Performance Center hosts:

1. Configure the port that will be used to ensure secure communication on the Performance Center server. Note that the port used by IIS for the SSL binding is 443. However, by default, the RemoteManagement Agent Service is using port 443. Either change the service's port or configure IIS to use a port other than 443 for the SSL binding.
2. Update the **web.config** file located in the **<Install path>\PCS** directory. Perform the following steps:
  - a. Create a backup copy of the **web.config** file and save it in a different folder.
  - b. To update the **web.config** file, you can replace it with the predefined **web.config-for\_ssl** file.

See step **2d** below.

If you have manual changes you want to preserve in the **web.config** file, you can manually modify the file. See step **2c** below.

- c. Edit the **web.config** file. Under the **<system.servicemodel><services>** tag, there are eight areas where the following comment appears: **Uncomment to enable SSL**. Uncomment the XML lines which appear thereafter. For example:

Before:

```
<endpoint binding="basicHttpBinding"
contract="HP.PC.PCS.ILabService"><identity>
<dns value="localhost"/></identity></endpoint>
<endpoint address="mex" binding="mexHttpBinding"
contract="IMetadataExchange"/>
<!-- Uncomment to enable SSL -->
<!-- endpoint binding="basicHttpBinding"
bindingConfiguration="BasicHttpBinding_TransportSecurity"
contract="HP.PC.PCS.ILabService"><identity>
<dns value="localhost"/></identity></endpoint -->
```

After:

```
<!--<endpoint binding="basicHttpBinding"
contract="HP.PC.PCS.ILabService"><identity>
<dns value="localhost"/></identity></endpoint>
<endpoint address="mex" binding="mexHttpBinding"
contract="IMetadataExchange"/> -->
<!-- Uncomment to enable SSL -->
<endpoint binding="basicHttpBinding"
bindingConfiguration="BasicHttpBinding_TransportSecurity"
contract="HP.PC.PCS.ILabService"><identity>
<dns value="localhost"/></identity></endpoint>
```

Under the **<system.servicemodel><behaviors>** tag, there are seven areas where you need to change the **httpGetEnabled** parameter to **false**, and the **httpsGetEnabled** parameter to **true**. For example

Before:

```
<serviceMetadata httpGetEnabled="true" httpsGetEnabled="false" />
```

After:

```
<serviceMetadata httpGetEnabled="false" httpsGetEnabled="true" />
```

- d. To replace **web.config** with the predefined **web.config-for\_ssl** file, copy **web.config-for\_ssl**

from the **<install path>\conf\httpsConfigFiles** directory and place it under the **<install path>\PCS** directory.

Rename **web.config-for\_ssl** to **web.config**.

3. Restart IIS.
4. If you have added the same Performance Center Server previously over HTTP, restart the ALM service.
5. Add the Performance Center Server to ALM and define the Internal URL to connect through IIS secure port. The URL must begin with **HTTPS**.

To configure secure communication on a Performance Center host for incoming requests from the ALM and Performance Center servers:

1. The default port used by a Performance Center host service is 8731. To configure SSL on a host for port 8731, refer to the Microsoft Web Site: How To Configure a Port with an SSL Certificate, using the following URL: <http://msdn.microsoft.com/en-us/library/ms733791.aspx>.
2. Perform the following steps to update the **LTOPSvc.exe.config** file:

- a. Create a backup copy of the **LtopSvc.exe.config** file located under the **<install path>\bin** directory, and save it in a different folder.
- b. To update the **LtopSvc.exe.config** file, you can replace it with the predefined **LTOPSvc.exe.config-for\_ssl** file. See step 2d below.

If you have manual changes you want to preserve in the **LTOPSvc.exe.config** file, you can manually modify the file. See step 2c below.

- c. Under the **<system.servicemodel><bindings><basicHttpBinding>** tag, there are two areas where the following comment appears: **Uncomment to enable SSL**. Uncomment the XML lines which appear thereafter. For example:

Before:

```
<binding name="BasicHttpBinding_ILoadTestingService"
closeTimeout="00:10:00" openTimeout="00:01:00"
receiveTimeout="00:20:00" sendTimeout="00:10:00"
allowCookies="false" bypassProxyOnLocal="false"
hostNameComparisonMode="StrongWildcard"
maxBufferSize="2147483647" maxBufferPoolSize="2147483647"
maxReceivedMessageSize="2147483647"
messageEncoding="Text" textEncoding="utf-8" transferMode="Buffered"
useDefaultWebProxy="true" <readerQuotas
maxDepth="2147483647" maxStringLength="2147483647"
maxArrayLength="2147483647" maxBytesPerRead="2147483647"
maxNameTableCharCount="2147483647" /> <!-- Uncomment to
enable SSL --> <!--<security mode="Transport">
```

```
<transport clientCredentialType="None"/>          </security>-->
</binding>
```

After:

```
<binding name="BasicHttpBinding_ILoadTestingService"
closeTimeout="00:10:00"          openTimeout="00:01:00"
receiveTimeout="00:20:00" sendTimeout="00:10:00"
allowCookies="false" bypassProxyOnLocal="false"
hostNameComparisonMode="StrongWildcard"
maxBufferSize="2147483647" maxBufferPoolSize="2147483647"
maxReceivedMessageSize="2147483647"
messageEncoding="Text" textEncoding="utf-8" transferMode="Buffered"
useDefaultWebProxy="true">          <readerQuotas
maxDepth="2147483647" maxStringContentLength="2147483647"
maxArrayLength="2147483647"          maxBytesPerRead="2147483647"
maxNameTableCharCount="2147483647" />
<!-- Uncomment to enable SSL -->          <security
mode="Transport">          <transport clientCredentialType="None"/>
</security>          </binding>
```

Under the **<system.servicemodel><services>** tag, switch between the non-secured and secured endpoints and base addresses. For example:

Before:

```
<endpoint contract="HP.PC.LTOP.Services.ILoadTestingService"
address="LoadTestingService" name="basicHttp"
binding="basicHttpBinding" bindingConfiguration="BasicHttpBinding_
ILoadTestingService"/>          <!-- Use the first endpoint for regular
communication and the second endpoint for SSL -->          <endpoint
contract="IMetadataExchange" binding="mexHttpBinding" name="mex" />
<!--<endpoint contract="IMetadataExchange"
binding="mexHttpsBinding" name="mex" />-->          <host>
<baseAddresses>          <!-- Use the first address for regular
communication and the second address for SSL -->          <add
baseAddress="http://localhost:8731/LTOP/LoadTestingService"/>
<!--<add
baseAddress="https://localhost:8731/LTOP/LoadTestingService"/>-->
</baseAddresses>          </host>          </service>
```

After:

```
<service name="HP.PC.LTOP.Services.LoadTestingService"
behaviorConfiguration="CommonBasicHTTPBehavior">          <endpoint
```



```

contract="HP.PC.LTOP.Services.ILoadTestingService"
address="LoadTestingService" name="basicHttp"
binding="basicHttpBinding" bindingConfiguration="BasicHttpBinding_
ILoadTestingService"/>      <!-- Use the first endpoint for regular
communication and the second endpoint for SSL -->      <!--
<endpoint contract="IMetadataExchange" binding="mexHttpBinding"
name="mex" />-->      <endpoint contract="IMetadataExchange"
binding="mexHttpsBinding" name="mex" />      <host>
<baseAddresses>      <!-- Use the first address for regular
communication and the second address for SSL -->      <!--<add
baseAddress="http://localhost:8731/LTOP/LoadTestingService"/>-->
      <add
baseAddress="https://localhost:8731/LTOP/LoadTestingService"/>
</baseAddresses>      </host>      </service>

```

Under the

**<system.servicemodel><behaviors><serviceBehaviors><behaviorname="CommonBasicHTTPBehavior">** tag, change the **httpGetEnabled** parameter to **false**, and the **httpsGetEnabled** parameter to **true**. For example

Before:

```
<serviceMetadata httpGetEnabled="true" httpsGetEnabled="false" />
```

After:

```
<serviceMetadata httpGetEnabled="false" httpsGetEnabled="true" />
```

- d. To replace **LTOPSvc.exe.config** with the predefined **LTOPSvc.exe.config-for\_ssl** file, copy **LTOPSvc.exe.config-for\_ssl** from the **<install path>\conf\httpsconfigfiles** directory and place it under the **<install path>\bin** directory.

Rename **LTOPSvc.exe.config-for\_ssl** to **LTOPSvc.exe.config**.

3. Restart Windows on the host.
4. Update the Performance Center server to ensure that the communication with the host is secure.

Edit the **PCS.config** file, located in the **<install path>\dat** path, as follows: Change the value of the **ltopIsSecured** parameter to **true**. For example:

Before:

```
<PCSSettings ltopPortNumber="8731" ltopIsSecured="false"
StartRunMaxRetry="3" DataProcessorPendingTimeoutMinutes="2880"/>
```

After

```
<PCSSettings ltopPortNumber="8731" ltopIsSecured="true"  
StartRunMaxRetry="3" DataProcessorPendingTimeoutMinutes="2880"/>
```

5. Restart IIS on the Performance Center Server.

## Working with Performance Center Agent

The Performance Center Agent runs on the Load Generators and enables communication between the Controller, Load Generators, and MI Listeners (in over firewall configurations). The agent receives instructions from the Controller to initialize, run, pause, and stop Vusers. At the same time, the agent also relays data on the status of the Vusers back to the Controller.

### Running the Performance Center Agent as a Process

In some cases, running GUI Vusers on remote machines, or terminal sessions, the Performance Center Agent must run as a process.

**To change the Performance Center Agent from a service to a process:**

On the host machine, select **Start > Programs > HP Software > Performance Center Host > Tools > Agent Runtime Settings Configuration**, and select **Manual log in to this machine**

### Running the Performance Center Agent as a Service

In most cases, the Performance Center Agent runs as a service.

**To change the Performance Center Agent from a process to a service:**

On the host machine, select **Start > Programs > HP Software > Performance Center Host > Tools > Agent Runtime Settings Configuration**, and select **Allow virtual users to run on this machine without user login**, and enter a valid user name and password.

## Configuring the Agent on Load Generator Machines

When working with protocols that use network files or Web protocol Vusers that access the Internet through a proxy server, the Load Generator agent must have network privileges. Note that the default user created by Performance Center, **System**, does not have network privileges.

By default, the agent runs as a service on the Load Generator machines. You can either run the agent as a process or you can continue running the agent as a service. To continue running it as a service, configure it to run the session using the local system account or another user account with network access privileges.

## Mapping Network Drives when Running Agent as Service

For all Windows platforms, when the user is logged off, the service cannot resolve the mapping of network drives. In cases when the service cannot work with mapped network drives, use the full path to the directory, for example, <\\<machine-name>\<directory>\>.

## Recommended Configuration for HP Load Generator (Linux)

You can increase the number of file descriptors, process entries, and amount of swap space by configuring the kernel.

For more information and recommendations on improving Linux Load Generator performance, see the *LoadRunner Installation Guide*.

## Establishing Connectivity with Oracle

When working with Oracle, ensure that the Oracle client (32-bit) is installed on the same machine as the Performance Center Server and that connectivity is established with the Oracle Server.

The **tnsnames.ora** file located on the Performance Center Server (for example: **..\oracle\product\<oracle client version>\client\_1\NETWORK\ADMIN\tnsnames.ora**) must contain a TNS entry for the source and target database servers. This entry can be copied from the **tnsnames.ora** file on the Oracle server to the Oracle client machine.

For example, for the Oracle database instance, **ALMInst**, the **tnsnames.ora** file, should contain the following entry:

```
ALMInst =
  (DESCRIPTION =
    (ADDRESS_LIST =
      (ADDRESS = (PROTOCOL = TCP)(HOST = <db_host>)(PORT = 1521))
    )
    (CONNECT_DATA =
      (SERVICE_NAME = ALMInst)
    )
  )
```

### To test that the TNS name entry is properly configured:

1. On the Performance Center Server machine, open a command prompt.
2. Type:

```
sqlplus <user/password>@<instancename>
```

where <instancename> is the name of the current instance.

3. Verify that you are successfully connected to the Oracle server.

## Establishing Connectivity with Oracle using SSL

When working with Oracle, ensure that the Oracle client (32-bit) is installed on the same machine as the Performance Center Server and that connectivity is established with the Oracle Server.

1. In the **tnsnames.ora** file located on the Performance Center Server (for example: **..\oracle\product\<oracle client version>\client\_1\NETWORK\ADMIN\tnsnames.ora**), set the protocol to TCPS.

For example, for the Oracle database instance, **ALMInst**, the **tnsnames.ora** file, should contain the following entry:

```
ALMInst =
  (DESCRIPTION =
    (ADDRESS_LIST =
      (ADDRESS = (PROTOCOL = TCPS)(HOST = <db_host>)(PORT = 1521))
    )
    (CONNECT_DATA =
      (SERVICE_NAME = ALMInst)
    )
  )
```

2. Add location of the Oracle wallet in the **sqlnet.ora** file. Copy **ewallet.p12** and **cwallet.sso** to the location specified in the **sqlnet.ora** file (request files from the Oracle DBA).

For example, for the Oracle wallet, the **sqlnet.ora** file, should contain the following entry:

```
WALLET_LOCATION =

  (SOURCE =

    (METHOD = FILE)

    (METHOD_DATA =

      (DIRECTORY = <drive>:\path to directory containing the ewallet.p12 and
      cwallet.sso files)

    )
  )
```

**To test connectivity:**

1. On the Performance Center Server machine, open a command prompt.
2. Type:

```
sqlplus <user/password>@<instancename>
```

where <instancename> is the name of the current instance.

3. Verify that you are successfully connected to the Oracle server.

## Enabling Downloading Standalone Applications

This section explains the steps necessary to enable you to download standalone applications from the Download Applications window.

**Note:** To access the Download Applications window, in Lab Management or in the ALM project, select **Tools > Download Standalone Applications**.

**To enable downloading standalone applications:**

1. Insert the HP ALM Performance Center Additional Components installation disk (DVD 2) and navigate to the **Additional Components** directory. This directory contains the applications' execution (.exe) files.

**Note:** The necessary .exe files for downloading VuGen, Analysis, Snapshot Viewer, Standalone Load Generator, Monitor over Firewall, and MI Listener, are located in the **Applications** directory, which is contained within the **Additional Components** directory.

2. On the Performance Center server, navigate to the **Downloads** directory, which is located in **<Performance Center Server installation directory>\PCWEB\Downloads**.
3. To enable downloading an application, copy the relevant execution file (.exe) from the **Additional Components** directory on the DVD to the **Downloads** directory on the Performance Center server.

**Note:** You may need to refresh the Download Applications window for the changes to take effect.

## Customizing the Download Applications Window

You can edit and customize the appearance of the Downloads Applications window. To customize the window, edit the **downloads.xml** file located in the **Downloads** directory on the Performance Center server.

The following tags in the **downloads** file control the following features on the window. Edit the tags as desired to change the appearance of the window.

- **App Name.** The name of the application.
- **Image.** Whether the application's icon appears to the left or to the right of the name.
- **File Name.** If you changed the name of the application's execution file, you must update this section so that it matches the new name of the execution file.
- **Description.** The application's description.

## Enabling MS-SQL Windows Authentication

This section describes how to configure an MS-SQL database with Windows authentication.

**Note:** The procedure below requires you to make changes to the MS-SQL database. It is strongly recommended that you make these changes using the SQL Server Management Studio tool.

### To enable Windows authentication:

1. Verify that the Performance Center Server, ALM server, and database server, all belong to the same domain, and that there is a domain user with administrator privileges common to all the machines.
2. Change users to domain users using the System Identity Utility. For more information, see the "Performance Center System Administration" chapter in the HP ALM Performance Center Guide.
3. Download the SQL Server Management Studio tool from the Microsoft Download Center (<http://www.microsoft.com/downloads/en/default.aspx>).
4. In SQL Server Management Studio, perform the following actions:
  - a. In the Object Explorer pane, expand the **Security** folder.
  - b. Right-click **Logins** and select **New Login**.
  - c. Enter the domain user in the **Login name** box, and make sure that **Windows Authentication** is selected.

**Note:** Verify that the domain user is assigned the same **Server Roles** as the database administrative user (**td\_db\_admin**).

5. Make sure that the relevant project is created in Site Administration with the **MS-SQL (Win Auth)** database type. For more information, see the "Configuring Servers and Parameters" chapter in the HP Application Lifecycle Management Administrator Guide.

## Configuring SSL for Load Generators

This section describes how to configure SSL communication to the load generators. It describes how to create and install a Certification Authority and a Client Certificate for working with SSL to secure communication to your load generators. It also describes how to enable SSL from Lab Management.

### How to Create and Copy Digital Certificates

#### 1. Create a Certification Authority (CA)

**Note:** This step describes how to create a CA using the **gen\_ca\_cert.exe** utility. If you are working on a Linux platform, use the **gen\_ca\_cert** utility instead.

On one of your Performance Center hosts, run the **gen\_ca\_cert** command from the **<Performance Center host installation folder>\bin** with at least one of the following options:

- **-country\_name**
- **-organization name**
- **-common\_name**

This process creates two files in the folder from which the utility was run: the CA Certificate (**ca\_cert.cer**), and the CA Private Key (**capvk.cer**).

**Note:** By default, the CA is valid for three years from when it is generated. To change the validation dates, use the **-nb\_time** (beginning of validity) and/or **-na\_time** (end of validity) options.

The following example creates two files: **ca\_igloo\_cert.cer** and **ca\_igloo\_pk.cer** in the current folder:

```
gen_ca_cert - country_name "North Pole" -organization_name "Igloo Makers" -
common_name "ICL" -CA_cert_file_name "ca_igloo_cert.cer" - CA_pk_file_name
"ca_igloo_pk.cer" -nb_time 10/10/2013 -na_time 11/11/2013
```

#### 2. Install Certification Authority (CA)

You need to install the CA on the hosts that you want to enable SSL communication including Controllers, Performance Center servers, Load Generators, and MI Listeners.

Run the **gen\_ca\_cert** utility from the **<Installation root folder>\bin** folder with one of the following parameters:

- **-install <name/path of the CA certificate file>**. Replaces any previous CA list and creates a new one that includes this CA only.
- **-install\_add <name/path of the CA certificate file>**. Adds the new CA to the existing CA list.

**Note:** The `-install` and `-install_add` options install the certificate file only. Keep the private key file in a safe place and use it only for issuing certificates.

**Note:** If your Load Generator is over firewall, install the CA on the MI Listener machine.

### 3. Create a Client Certificate

**Note:** This step describes how to create a client certificate using the `gen_cert.exe` utility. If you are working on a Linux platform, use the `gen_cert` utility instead.

On one of your Performance Center hosts, run the `gen_cert` command from the **<Performance Center host root folder>\bin** folder with at least one of the following options:

- `-country_name`
- `-organization_name`
- `-organization_unit_name`
- `-eMail`
- `-common_name`

It is important to note the following:

- The CA Certificate and the CA Private Key files are necessary for the creation of the certificate. By default, it is assumed that they are in the current folder, and are named `cacert.cer` and `capvk.cer` respectively. In any other case, use the `-CA_cert_file_name` and `-CA_pk_file_name` options to give the correct locations.
- The certificate file is created in the folder from which the utility was run. By default, the file name is `cert.cer`.

### 4. Install a Client Certificate

You need install the client certificate on the hosts that you want to enable SSL including Performance Center hosts (used as Controllers), Performance Center servers, Load Generators, and MI Listeners.

Run the `gen_cert` utility from the **<Performance Center host root folder>\bin** folder with the following parameter:

**`-install <name/path of the client certificate file>`**

**Note:** Steps 3 and 4 describe how to install the same client certificate. Alternatively, you can create a new client certificate on each machine.

5. On the Load Generator machines, open Performance Center Agent Configuration and click **OK** to restart the agent configuration. On the MI Listener machines, open Agent Configuration and click



**OK** to restart the agent configuration.

## Enabling SSL Communication for Load Generators on Lab Management

1. Log in to Lab Management. For more details, see "[Logging In to Lab Management](#)" on page 36.
2. On the Lab Management sidebar, under **Lab Resources** select **Hosts**.

3. Select an existing host or load generator over a firewall host, and click **Testing Host Details** .

Alternatively, click New Testing Host  to create a new host.

4. In the Testing Host Details dialog box or the Testing Host dialog box, in the **Enable SSL** field, select **Y**.



## Chapter 5: Upgrading Previously Created Projects

To work with projects from a previous version, you will need to upgrade your projects to the latest version of Performance Center. For details, see the *HP Application Lifecycle Management Installation and Upgrade Guide*.



# Part 3: Working with Firewalls



# Chapter 6: Working with Firewalls

You can set up your Performance Center system to run Vusers and monitor servers over a firewall.

This chapter includes:

- [About Using Firewalls in Performance Center](#) ..... 80
- [Example: Over Firewall Deployment](#) ..... 82
- [Setting Up the System to Use Firewalls: Basic Steps](#) ..... 82
- [Installing Over Firewall Components](#) ..... 83
- [Initial Configuration of the Over Firewall System](#) ..... 84
- [Specifying MI Listeners in ALM](#) ..... 87

## About Using Firewalls in Performance Center

Working with a firewall means that you can prevent unauthorized access to or from a private network, on specific port numbers.

For example, you can specify that no access is allowed to any port from the outside world, with the exception of the mail port (25), or you can specify that no outside connection is allowed from any ports to the outside except from the mail port and WEB port (80). The port settings are configured by the system administrator.

In a regular performance test (not over a firewall), the Controller has direct access to the Performance Center agents running on remote machines. This enables the Controller to connect directly to those machines.

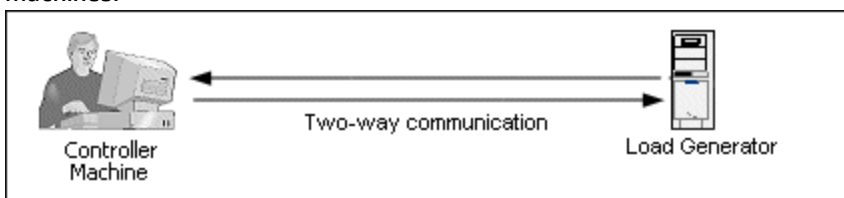

When running Users or monitoring applications over a firewall, this direct connection is blocked by the firewall. The connection cannot be established by the Controller, because it does not have permissions to open the firewall.

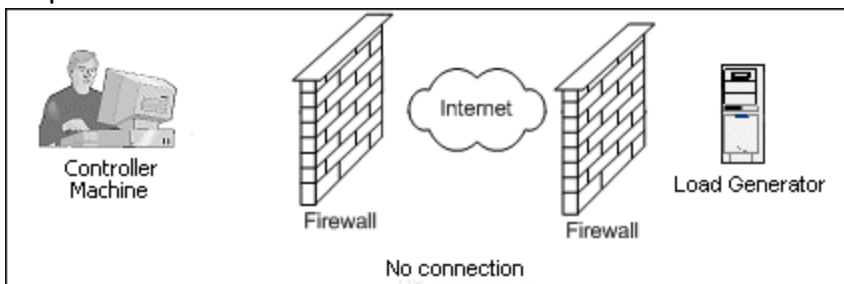

Performance Center solves this problem by using a communication configuration based on HTTPS or secured TCP/IP. This configuration uses the standard SSL port on the firewall (port 443). For more information on HTTPS and TCP/IP system configuration, see ["Setting Up Your Deployment \(TCP or HTTPS\)" on page 84](#).

A Performance Center agent is installed on Load Generators running Users over a firewall, and on Monitor Over Firewall machines that monitor the servers that are located over a firewall. The agent communicates with the MI Listener machine through port 443 in the firewall.

The MI Listener is a component that serves as router between the Controller and the Performance Center agent.



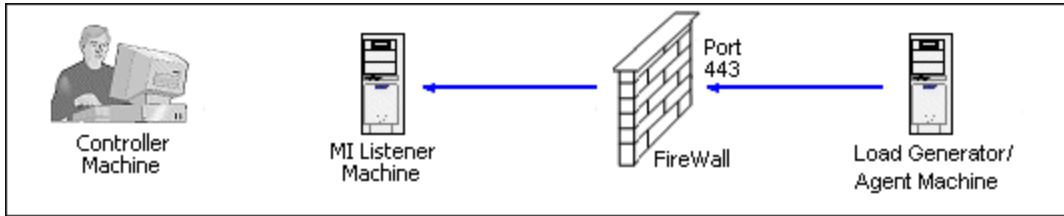

When the Performance Center agent connects to the MI Listener, the MI Listener keeps a listing of the connection to the agent using a symbolic name that the agent passed to it.

When the Controller connects to the MI Listener, it communicates to the MI Listener through port 50500.

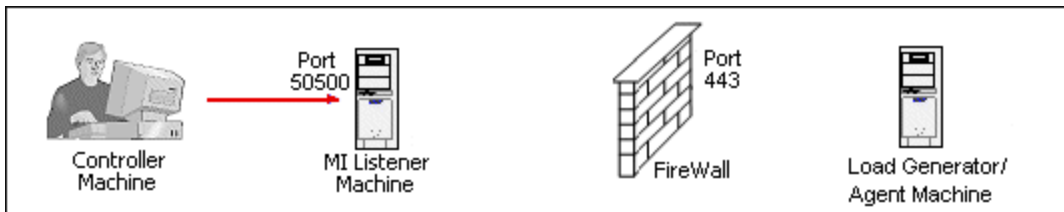

The Controller uses a symbolic name for the agent, and provides the MI Listener machine's name. If there has been a connection from the agent with the same symbolic name to this MI Listener, the connection is made between the Controller and the agent. After you have a connection with the agent, you can run Vusers over firewall or monitor AUT machines behind the firewall.

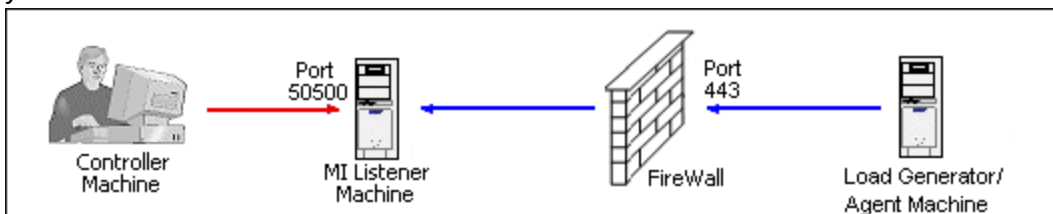

## Example: Over Firewall Deployment

The following diagram is a basic example of a Performance Center deployment over a firewall.

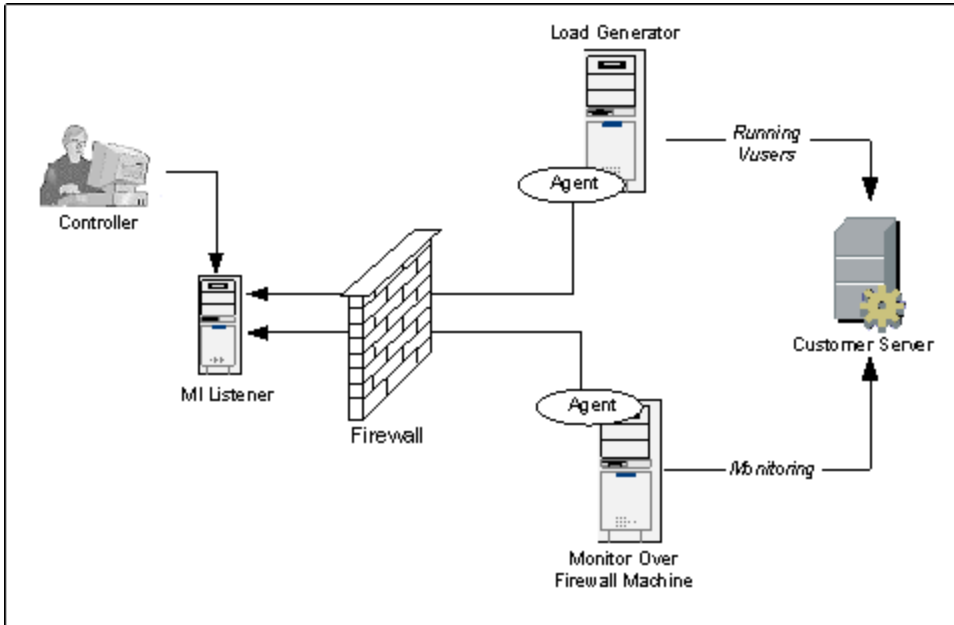

As explained in the previous section, the Performance Center agent is installed on both the Load Generator machine and the Monitor Over Firewall machine. During installation, the Performance Center agent is added as a Windows service.

The MI Listener serves as a router between:

- The agent on the Load Generator machine and the Controller, enabling the Controller to run Users over a firewall.
- The agent on the Monitor Over Firewall machine and the Controller, enabling the Controller to monitor the servers that are located over a firewall.

## Setting Up the System to Use Firewalls: Basic Steps

Setting up the system to use firewalls involves the following stages of configuration:

| Stage   | Description   |
|---|---|
| <b>Installation and initial configuration</b> | Install the necessary components and perform initial configuration settings. For details, see <a href="#">"Installing Over Firewall Components"</a> on the next page, and <a href="#">"Initial Configuration of the Over Firewall System"</a> on page 84. |
| <b>Enabling running Users over a firewall</b> | When there is a firewall between the Controller and Load Generator host machines, set up the system to run Users over the firewall. For details, see <a href="#">"Running Users Over a Firewall"</a> on page 89.  |

| Stage                                      | Description  |
|--|--|
| <b>Enabling monitoring over a firewall</b> | Set up your system to monitor the application under test (AUT) when there is a firewall between the Controller and the AUT. For details, see <a href="#">"Monitoring Over a Firewall" on page 93</a> .   |
| <b>Checking Connectivity</b>               | After installing and configuring all the necessary components, check that you are able to establish a connection between the Performance Center agent, the MI Listener, and the Controller machine. For details, see <a href="#">"Checking Connectivity" on page 106</a> . |

The following flow chart provides a general outline of the steps that you need to perform to set up your system to work with firewalls.

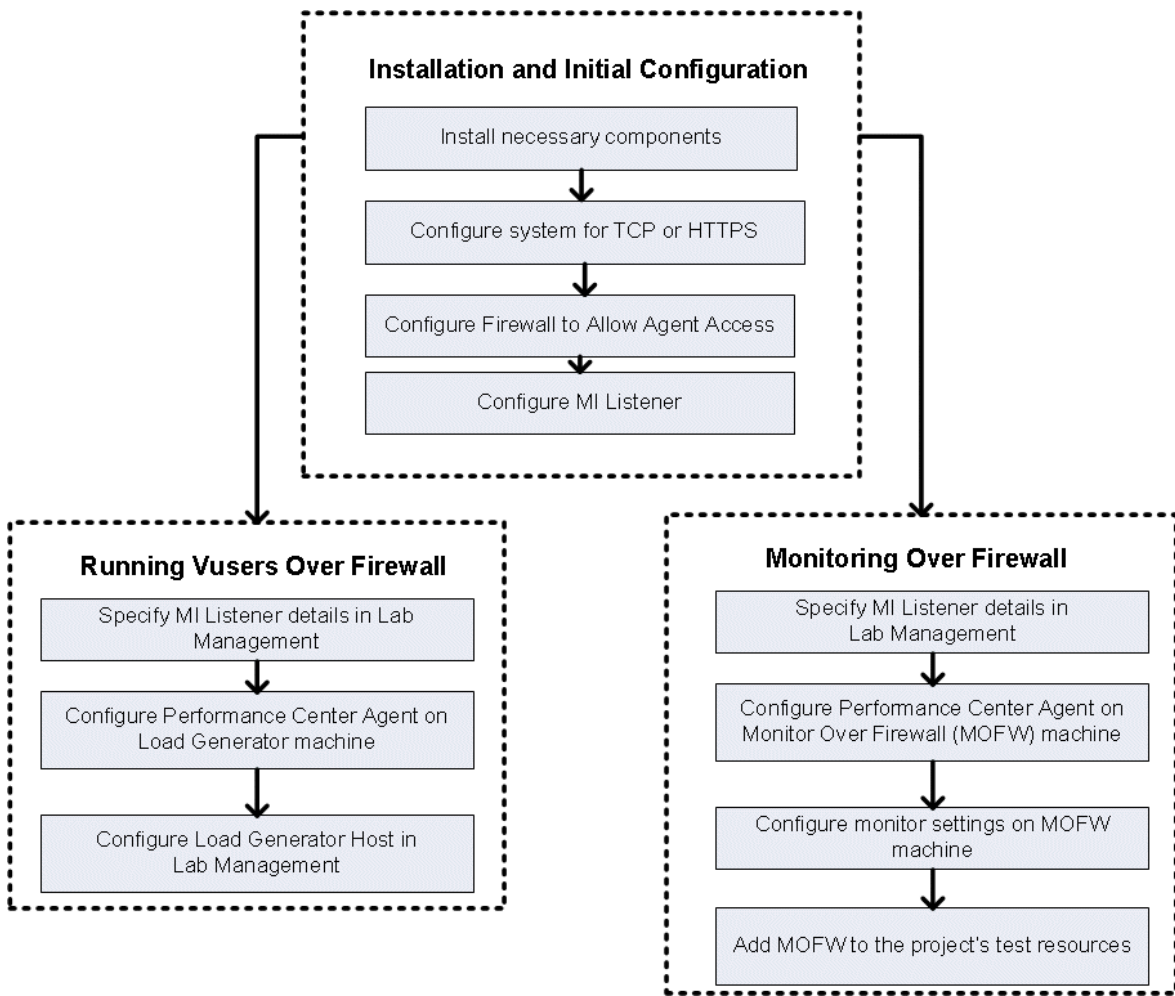

## Installing Over Firewall Components

To enable over firewall communication, ensure that you have installed the following Performance Center components:

| Component                              | Description  |
|--|--|
| <b>MI Listener</b>                     | <p>Serves as a router between the Controller and the Performance Center agent. You install the MI Listener component on a dedicated machine. For installation instructions, see <a href="#">"Installing Standalone Components (Windows)" on page 45.</a></p> <p>For instructions on configuring the MI Listener machine, see <a href="#">"Configuring the MI Listener" on page 86.</a></p>         |
| <b>Monitor Over Firewall component</b> | <p>Used to monitor the servers that are located over a firewall. You install the Monitors over Firewall component on a dedicated machine. For installation instructions, see <a href="#">"Installing Standalone Components (Windows)" on page 45.</a></p> <p>For information about configuring the Monitor Over Firewall machine, see <a href="#">"Monitoring Over a Firewall" on page 93.</a></p> |

## Initial Configuration of the Over Firewall System

After you have installed the necessary components, you are ready to configure your over firewall system.

### To perform initial configuration of your over firewall system:

- 1. Configure the system according to TCP or HTTPS.**  
See ["Setting Up Your Deployment \(TCP or HTTPS\)" below.](#)
- 2. Modify the firewall settings to enable communication between the machines on either side of the firewall.**  
See ["Configuring the Firewall to Allow Agent Access" on page 86.](#)
- 3. Configure the MI Listener.**  
See ["Configuring the MI Listener" on page 86.](#)

## Setting Up Your Deployment (TCP or HTTPS)

To run Vusers or monitor servers over the firewall, configure your system according to one of the following configurations. Note that these configurations contain a firewall on each LAN. There may also be configurations where there is a firewall for the Over Firewall LAN only.

- **TCP Configuration**

The TCP configuration requires every Performance Center agent machine behind the customer's firewall to be allowed to open a port in the firewall for outgoing communication.

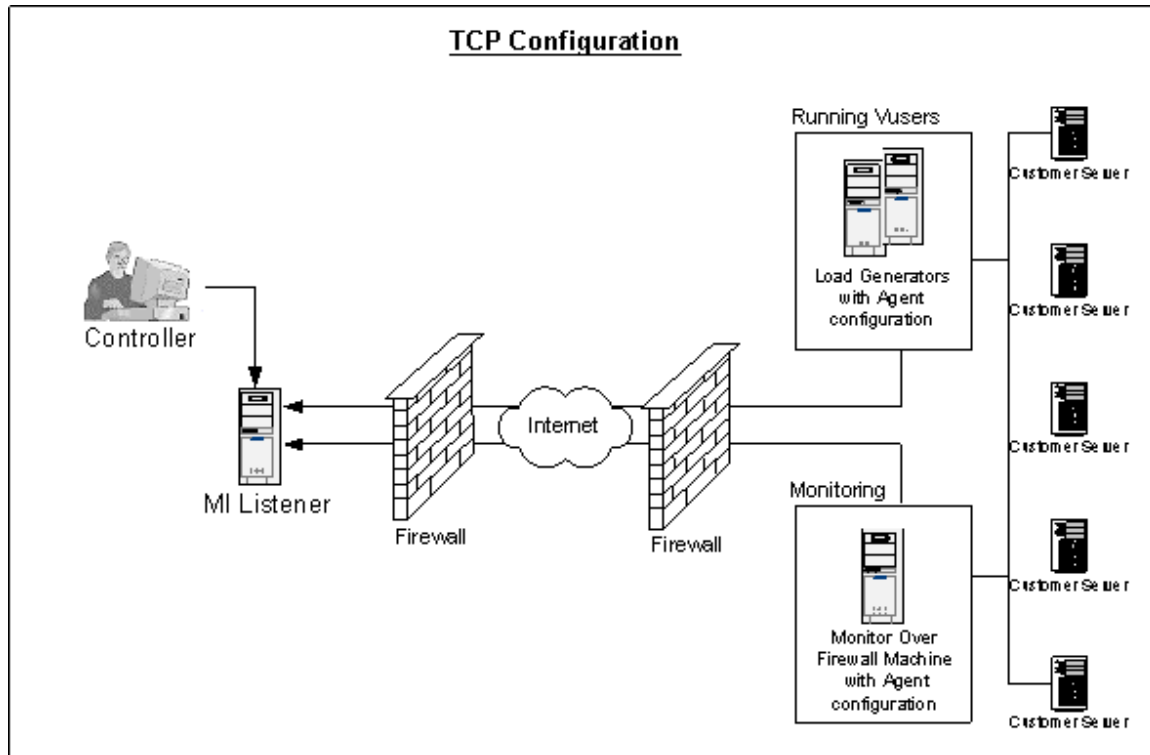

• **HTTPS Configuration**

In the HTTPS configuration, only one machine (the proxy server) is allowed to open a port in the firewall. Therefore it is necessary to tunnel all outgoing communications through the proxy server.

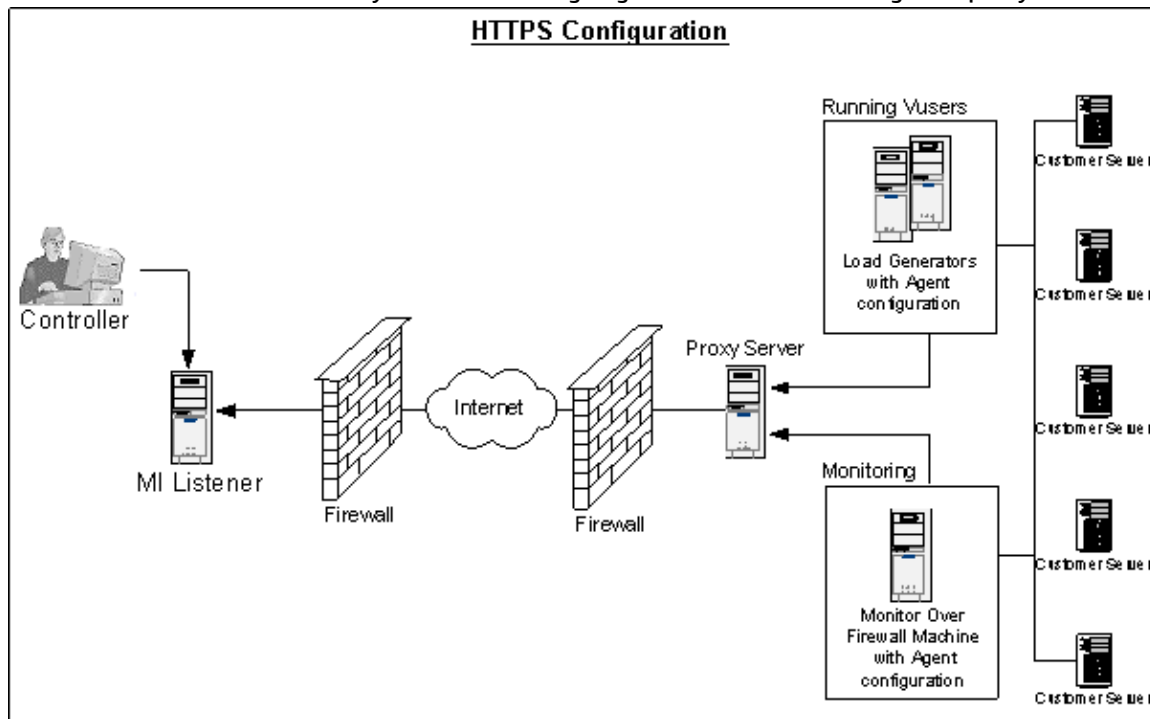

## Configuring the Firewall to Allow Agent Access

You modify your firewall settings to enable communication between the machines inside the firewall and machines outside the firewall.

### TCP Configuration

The Performance Center agent attempts to establish a connection with the MI Listener using port 443, at intervals specified in the Connection Timeout field in the Agent Configuration dialog box. To enable this connection, allow an outgoing connection for HTTPS service on the firewall for port 443. The agent initiates the connection and the MI Listener communicates with the Load Generator through the connection.

### HTTPS Configuration

The Performance Center agent attempts to establish a connection with the MI Listener, using the proxy port specified in the Proxy Port field, and at intervals specified in the Connection Timeout field in the Agent Configuration dialog box. When the connection to the proxy server is established, the proxy server connects to the MI Listener. To enable this connection, allow an outgoing connection for HTTPS service on the firewall for port 443. The proxy server can then connect to the MI Listener, and the MI Listener can connect back to the agent through the proxy server. From this point on, the agent listens to commands from the MI Listener.

### Local System Account Configuration

If you intend to start the Performance Center agent service from the Local System account, you need to grant it permissions. If you do not provide permissions, the monitor graph will not display any data.

To grant it permissions, add a local user on the AUT machine with the same name and password as the local user on Agent machine. Add the AUT local user to the Performance Monitor Users group and restart the Agent process.

## Configuring the MI Listener

To enable running Vusers or monitoring over a firewall, you need to install the MI Listener on one or more machines in the same LAN as the Controller outside the firewall. For installation instructions, see, ["Installing Standalone Components \(Windows\)" on page 45](#).

### To configure the MI Listener:

1. On the MI Listener server, open port 443 for the incoming traffic.
2. Select **Start > Administrative Tools > Services**. Stop **LoadRunner Agent Service**.
3. Select **Start > All Programs > HP Software > HP LoadRunner > Advanced Settings > MI Listener**

**Configuration**, or run  
**<LoadRunner root folder>\launch\_service\bin\MILsnConfig.exe.**

- Set each option as described in the following table:

| Option                           | Description  |
|----------------------------------|--|
| <b>Check Client Certificates</b> | Select <b>True</b> to request that the client send an SSL certificate when connecting, and to authenticate the certificate.<br><b>Default value:</b> False |
| <b>Private Key Password</b>      | The password that may be required during the SSL certificate authentication process.<br><b>Default value:</b> none   |

Click **OK** to save your changes or **Use Defaults** to use the default values.

- Select **Start > Administrative Tools > Services**. To restart the LoadRunner Agent Service, select **Start > All Programs > HP Software > HP LoadRunner > Advanced Settings > Agent Service**.
- Make sure that no Web Servers are running on the MI Listener or Monitor over Firewall machine. These servers use port 443 and will not allow the access required by the listening and monitoring processes

## Specifying MI Listeners in ALM

In Lab Management, you specify one or more MI Listeners to enable running Vusers or monitoring data over a firewall.

### To add an MI Listener:

- On the Lab Management sidebar, under **Performance Center**, select **MI Listeners**.
- In the MI Listeners module, click the **New MI Listener**  button. The New MI Listener dialog box opens.
- Enter the following details:

| Field                   | Description  |
|-------------------------|--|
| <b>Description</b>      | A description of the MI Listener.  |
| <b>Public IP</b>        | The public IP address of the MI Listener.<br><b>Note:</b><br>If you have two different IP addresses for the same MI Listener, one for public communication with a Load Generator located over a firewall and a second for internal communication with the Controller, enter the public IP address here. Enter the <b>internal IP address</b> in the <b>MI Listener Name</b> field (see below). |
| <b>MI Listener Name</b> | The host name of the MI Listener.<br><b>Note:</b> If you have two different IP addresses for the same MI Listener—one for internal communication with the Controller and a second for public communication with a Load Generator located over a firewall—enter the <b>internal IP address</b> here. Enter the public IP address in the <b>Public IP</b> field (see above).                     |

| Field          | Description   |
|----------------|---|
| <b>Purpose</b> | The role designated to the MI Listener: <ul style="list-style-type: none"><li data-bbox="418 342 824 369">• Diagnostics data collection over a firewall</li><li data-bbox="418 384 683 411">• Monitoring over a firewall</li><li data-bbox="418 426 724 453">• Running Vusers over a firewall</li></ul> |

4. Click **OK**. The MI Listener is added to the table.



# Chapter 7: Running Vusers Over a Firewall

You can set up Performance Center to run Vusers over a firewall.

This chapter includes:

- [Running Vusers Over a Firewall: Basic Steps](#) .....90
- [Configuring Hosts to Run Vusers Over a Firewall](#) .....91

## Running Vusers Over a Firewall: Basic Steps

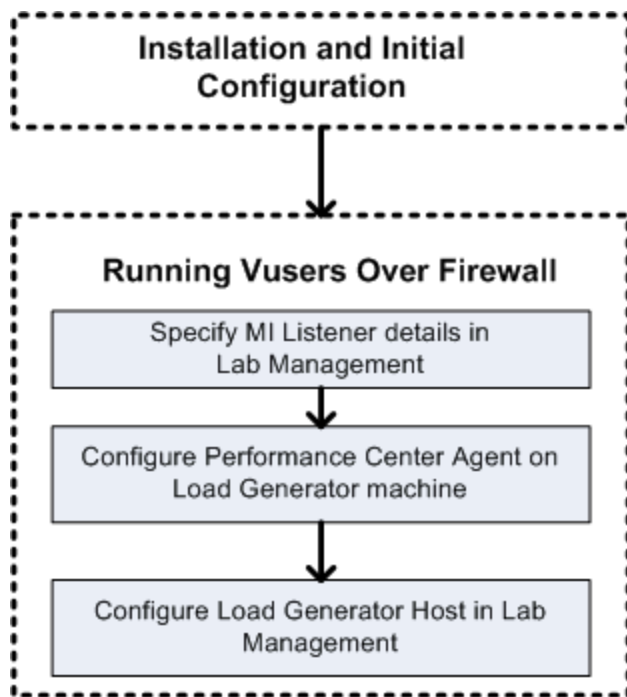

**Note:** Before you configure your system to run Vusers over the firewall, ensure that you have completed the configuration steps described in ["Initial Configuration of the Over Firewall System" on page 84](#).

### To run Vusers over a firewall:

1. In Lab Management, specify the details of the MI Listener that will be used to run Vusers over the firewall. For details, see ["Specifying MI Listeners in ALM" on page 87](#).
2. Configure the Performance Center agent on each Load Generator machine that will run over a firewall to communicate with the MI Listener.

For information on how to configure the Performance Center agent, see ["Configuring the Performance Center Agent" on page 101](#).

**Note:** After you configure the Performance Center agent on the Load Generator machine, you can edit the configuration settings from Lab Management. For more information, see the *HP ALM Lab Management Guide*.

3. In Lab Management, configure the relevant Load Generator hosts to run over a firewall. For details, see ["Configuring Hosts to Run Vusers Over a Firewall" on the next page](#).

## Configuring Hosts to Run Vusers Over a Firewall

To use a Performance Center host to run Vusers over a firewall, you need to configure the relevant hosts as Load Generators in Lab Management.

Part of the process of configuring a Performance Center host involves selecting a location for your host. For example, locations can be defined according to physical areas. The location also determines whether the host is located over a firewall.

Before you configure the host, you need to ensure that you have added a location over a firewall. When you are configuring a host to operate over a firewall, you select a location that is located over a firewall.

This section describes the basic steps of how to add a host as a Load Generator for running Vusers over a firewall. For detailed information about adding hosts in Performance Center, refer to the HP ALM Lab Management Guide.

### To configure a host to run Vusers over a firewall:

#### 1. Add the location that is over a firewall.

- a. On the Lab Management sidebar, under **Lab Resources**, select **Locations**.
- b. In the Host Locations module, click the **New Host Location**  button. The New Host Location dialog box opens.
- c. Enter the following details:

| Field                | Description  |
|----------------------|--|
| <b>Description</b>   | A description of the host location.  |
| <b>Location Name</b> | The name of the host location. The name should have a logical connection to the host location. |
| <b>Over Firewall</b> | Indicates whether the host location is over a firewall.  |

#### 2. Add the over firewall host.

- a. On the Lab Management sidebar, under **Lab Resources**, select **Hosts**.
- b. In the Host module, click the **New Host**  button. The New Host dialog box opens.
- c. Enter the following details:

| Field                   | Description  |
|-------------------------|--|
| <b>Belongs to Pools</b> | The host pools to which the host is assigned.<br>Host pools enable you to control which hosts are allocated to which projects. |
| <b>Description</b>      | A description of the host.   |
| <b>Host Attributes</b>  | Attributes of the host.<br><b>Example:</b> Memory, strength, installed components  |

| Field               | Description  |
|---------------------|--|
| <b>Installation</b> | Indicates the type of host installation.<br>For a standalone installation of the Load Generator, select <b>Windows Standalone LG</b> .   |
| <b>Location</b>     | The location of the host that is over the firewall.  |
| <b>MI Listener</b>  | The IP address or host name of the MI Listener that enables data collection.   |
| <b>Name</b>         | The fully qualified domain name or IP address of the host that was assigned when creating the host.  |
| <b>Priority</b>     | A rank assigned to the host. The higher the priority you give the host, the more likely the host will be allocated to a test. There are a number of criteria to consider when assigning priority. The main considerations are whether the host is a dedicated machine or a shared resource, and the type of hardware installed on the machine.   |
| <b>Purpose</b>      | A host over a firewall can only have a Load Generator purpose.   |
| Enable SSL          | Indicates whether the Load Generator is to communicate with the Controller via SSL (Secure Socket Layer) or not. This option is available when the Load Generator is located over a firewall.<br><b>Note:</b> The Load Generator uses SSL to communicate with the Controller during run time only. For non runtime functionality (including collating results), the Load Generator does not use SSL as the communication protocol. |
| <b>Status</b>       | The status of the host. An indicator is displayed next to the host name, representing its current status.<br>The possible statuses are: <ul style="list-style-type: none"> <li>○ <b>Operational.</b> The host machine is up and running.</li> <li>○ <b>Non-operational.</b> The host machine is down.</li> <li>○ <b>Unavailable.</b> There is no information available about the status of the host.</li> </ul>                    |

# Chapter 8: Monitoring Over a Firewall

You can set up Performance Center to monitor servers over a firewall.

This chapter includes:

- [Monitoring Over a Firewall: Basic Steps](#) ..... 94
- [Configuring Monitor Settings](#) ..... 95
- [Configuring the Project to Receive Monitor Over Firewall Information](#) ..... 98
- [Editing Monitor Over Firewall Machines During a Test Run](#) ..... 99

## Monitoring Over a Firewall: Basic Steps

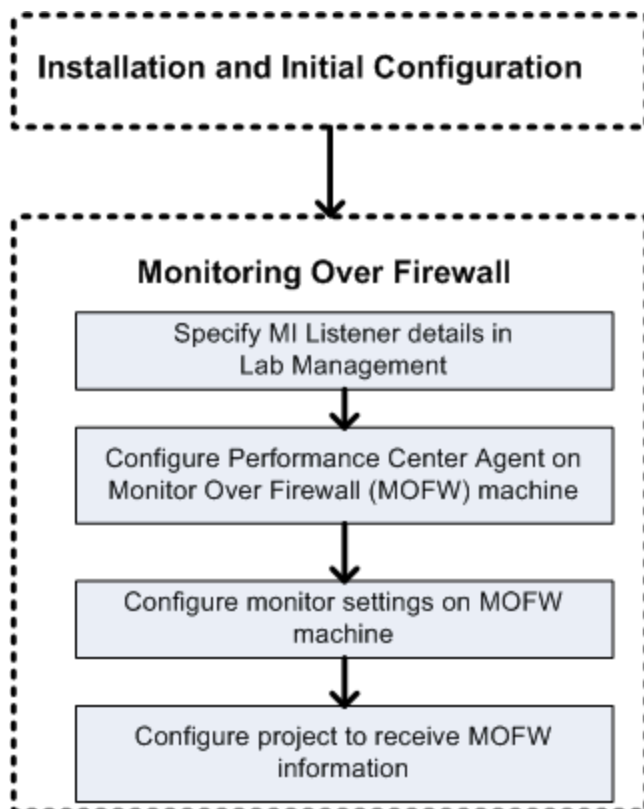

**Note:** Before you configure your system to monitor servers over a firewall, ensure that you have completed the configuration steps described in ["Initial Configuration of the Over Firewall System"](#) on page 84.

### To set up your system to monitor servers over a firewall:

1. In Lab Management, specify the details of the MI Listener that will be used to monitor servers over the firewall. For details, see ["Specifying MI Listeners in ALM"](#) on page 87.
2. Configure the Performance Center agent on each Monitor Over Firewall machine to communicate with the MI Listener.  
For details, see ["Configuring the Performance Center Agent"](#) on page 101.
3. Use the Monitor Configuration tool to configure the servers to monitor and define specific measurements that Performance Center collects for each monitored server.  
For details, see ["Configuring Monitor Settings"](#) on the next page.
4. In the relevant project, establish a connection between the tests you are running and the Monitor

Over Firewall machines.

For details, see ["Configuring the Project to Receive Monitor Over Firewall Information"](#) on page 98.

## Configuring Monitor Settings

You configure the monitor settings from the Monitor Over Firewall machine, using the Monitor Configuration tool. You select the type of monitors to run and the server whose resources you want to monitor, add the measurements to monitor for each server, and specify the frequency at which the monitored measurements are to be reported.

### To configure monitor settings:

1. On the Monitor Over Firewall machine, choose **Start > Programs > HP LoadRunner > Advanced Settings > Monitor Configuration**. For machines without the complete Performance Center installation, choose **Start > Programs > Server Monitor > Monitor Configuration**. The Monitor Configuration dialog box opens.

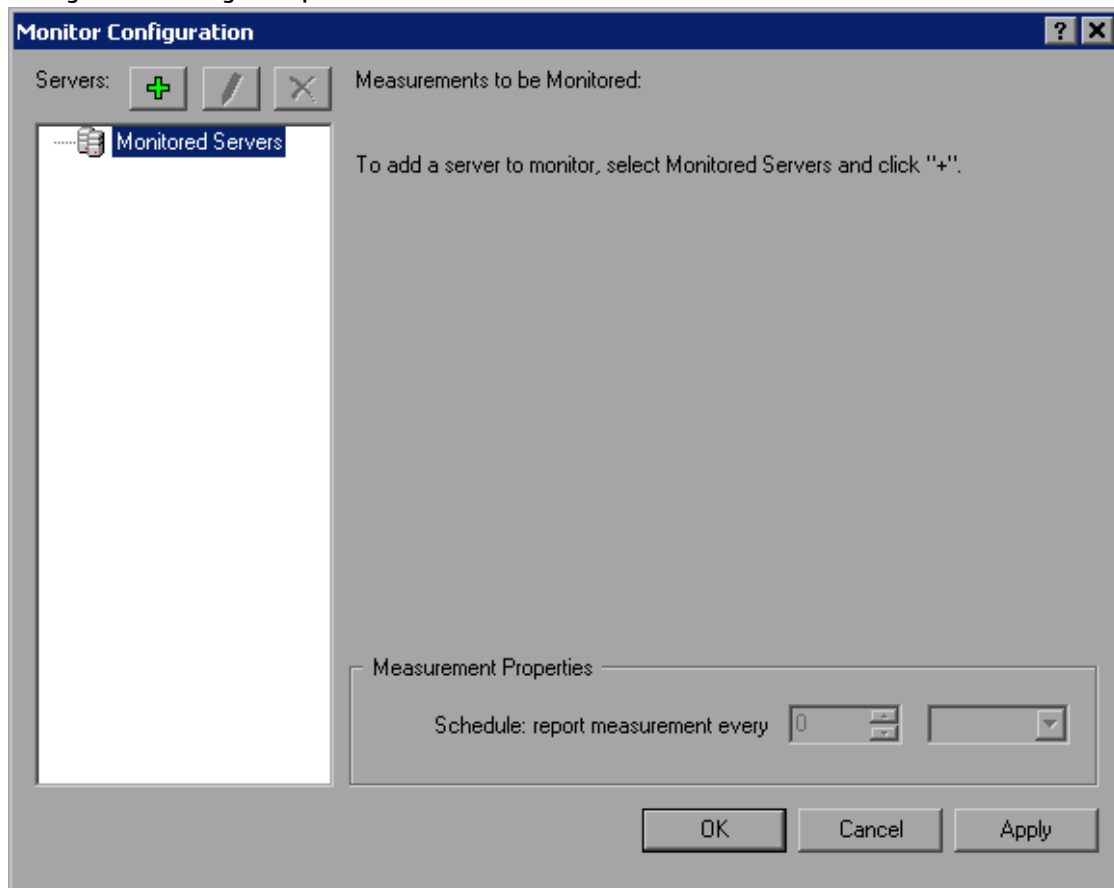

2. Click the **Add Server** button . The New Monitored Server Properties dialog box opens.

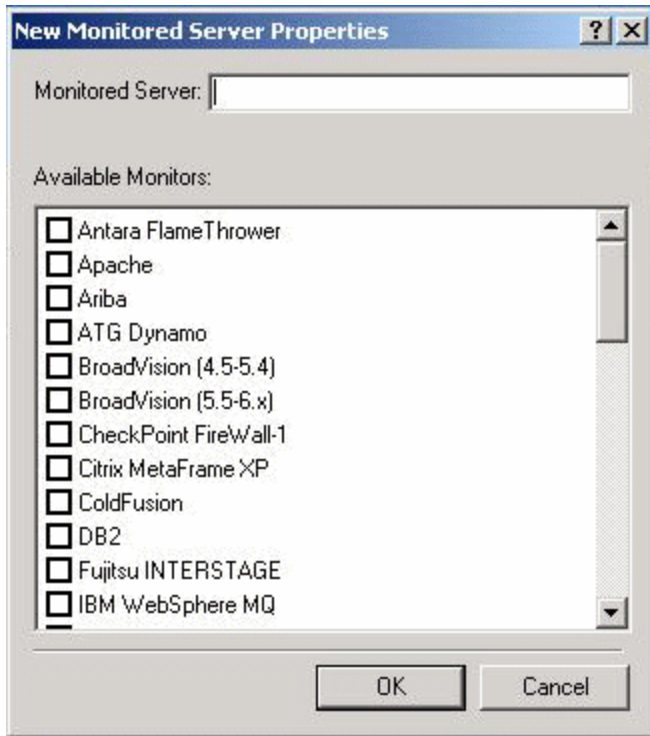

3. In the **Monitored Server** box, type the name or IP address of the server whose resources you want to monitor.

**Note:** To add several servers simultaneously, you can specify IP ranges, or separate the server names or IP ranges with commas. For example, 255.255.255.0-255.255.255.5, or server1, server2.

4. From the **Available Monitors** list, select the monitors suitable for the server being monitored.
5. Click **OK** to close the New Monitored Server Properties dialog box. The Monitored Servers list is displayed in the Monitor Configuration dialog box.

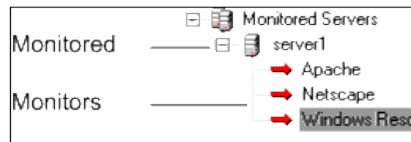

Default measurements are displayed for some of the monitors in the Measurements to be Monitored section. You can specify the frequency at which to report the measurements in the Measurement Properties section.

6. To add additional monitored servers to the list, repeat the steps above.
7. To edit the monitor configuration properties for a server, click the **Edit** button . The Monitored Server Properties dialog box opens enabling you to edit the monitors for the server



whose resources you are monitoring.

8. Click **Apply** to save your settings.

## Cloning a Monitored Server's Properties

To monitor the same properties on different server machines, you can clone a selected server's properties using the Clone Monitored Server Properties dialog box.

### To clone a monitored server's properties:

1. Open the Monitor Configuration dialog box.
2. Right-click the server you want to clone, and select **Clone**. The Clone Monitored Server Properties dialog box opens.

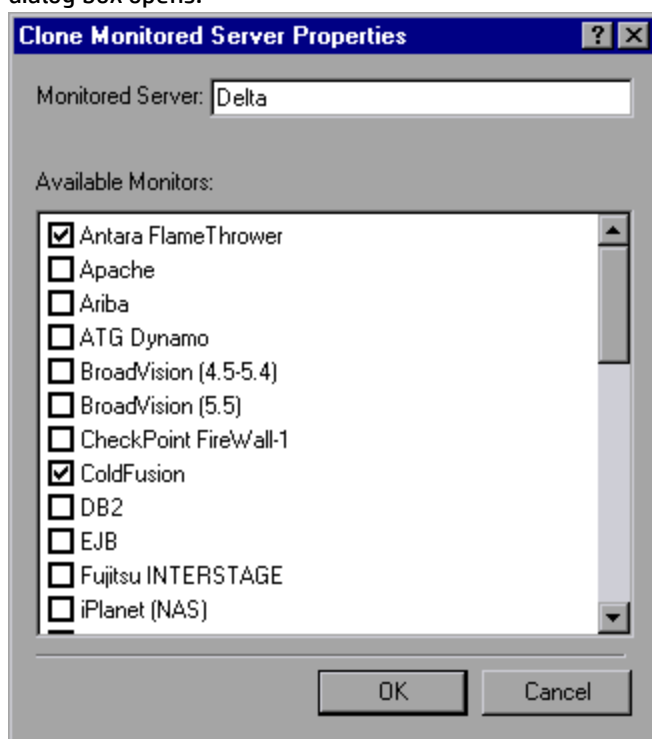

3. In the **Monitored Server** box, type the name or IP address of the cloned server you want to create.



**Tip:** To create several cloned servers simultaneously, you can specify IP ranges, or separate the server names or IP ranges with commas. For example, 255.255.255.0-255.255.255.5, or server1, server2.

4. The **Available Monitors** list displays the monitors that were selected for the server being cloned. Select additional suitable monitors for the cloned server.
5. Click **OK** to close the Clone Monitored Server Properties dialog box. The cloned server is displayed in the Monitored Servers list.
6. Click **Apply** to save your settings.

## Adding and Removing Measurements

After you configure one or more server machines to monitor, you add measurements to monitor for each server. If Performance Center added default measurements, you can edit them as required.

### To add a measurement to monitor:

1. Open the Monitor Configuration dialog box.
2. Select a server from the Monitored Servers list.
3. Click the **Add Measurement** button . Select the appropriate monitor. A dialog box opens, enabling you to choose measurements for the monitor you selected.
4. Select the measurements that you want to monitor, and click **OK**.
5. Click **Apply** to save your settings.

### To remove a measurement from the measurements list:

1. Select the measurement, and click the **Delete** button .
2. Click **Apply** to save your settings.

## Configuring Measurement Frequency

After you have configured monitor measurements, you set a schedule for reporting each measurement.

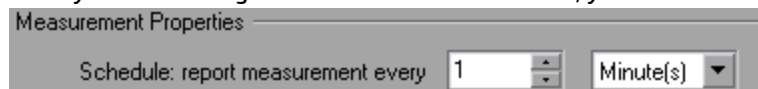

### To configure measurement frequency:

1. In the Monitor Configuration dialog box, under the **Measurement Properties** section, select the configured server measurement you want to schedule.
2. Specify the frequency at which you want Performance Center to report the measurement.
3. Click **Apply** to save your settings.

## Configuring the Project to Receive Monitor Over Firewall Information

After you configure the monitors, you configure the project to receive Monitor Over Firewall information during performance test runs.

**Note:** The steps in the section are described in more detail in the section about monitor profiles in the HP ALM Performance Center Guide.

**To configure the project to receive Monitor Over Firewall information:**

1. Add a monitor over firewall which can be accessed by performance tests in this project.
  - a. On the ALM sidebar, select **Test Resources**.
  - b. In the Test Resources module, right-click and select **New Resource**.
  - c. In the **Type** box, select **Monitor Over Firewall**.
  - d. Enter a name, the machine key, and select the MI Listener with which the monitor is to connect.
2. Select the Monitor Over Firewall agent to use in a specific performance test.
  - a. In the Test Plan module, right-click a performance test, and click **Edit Test** to open the test in the Performance Test Designer window.
  - b. In the Monitors tab, select the Monitor Over Firewall agent.

## Editing Monitor Over Firewall Machines During a Test Run

While a performance test is running, you can change the status of a Monitor Over Firewall agent or add another monitor to the test.

**To modify the Monitor Over Firewall machines:**

1. On the Test Run page, click the **Design** button. The Performance Test Designer window opens.
2. Click **Settings**. The Settings dialog box opens.
3. In the **Server Monitors** tab, you can view the Monitor Over Firewall agents that are monitoring the test, as well as their connection status.
  - To connect or disconnect a Monitor Over Firewall agent, click the **Connect/Disconnect** button.
  - To add a Monitor Over Firewall agent to the test, select it from the **Add Monitor Over Firewall** list.
4. Click **OK**.
5. Click **Close** to close the Settings dialog box.



# Chapter 9: Configuring the Performance Center Agent

You can set up your Performance Center system to run Vusers and monitor servers over a firewall. As part of the process of setting up your Performance Center system to work over firewalls, you configure the Performance Center agent.

This chapter includes:

- [About Configuring Performance Center Agents Over the Firewall](#) ..... 102
- [Configuring the Windows Performance Center Agent](#) ..... 102
- [Configuring and Running the Linux Performance Center Agent](#) ..... 103
- [Agent Configuration Settings](#) ..... 105
- [Checking Connectivity](#) ..... 106

## About Configuring Performance Center Agents Over the Firewall

As part of the process of setting up your Performance Center system to work over firewalls, you configure the Performance Center agent on each Load Generator machine that will be running over a firewall and on each Monitor Over Firewall machine.

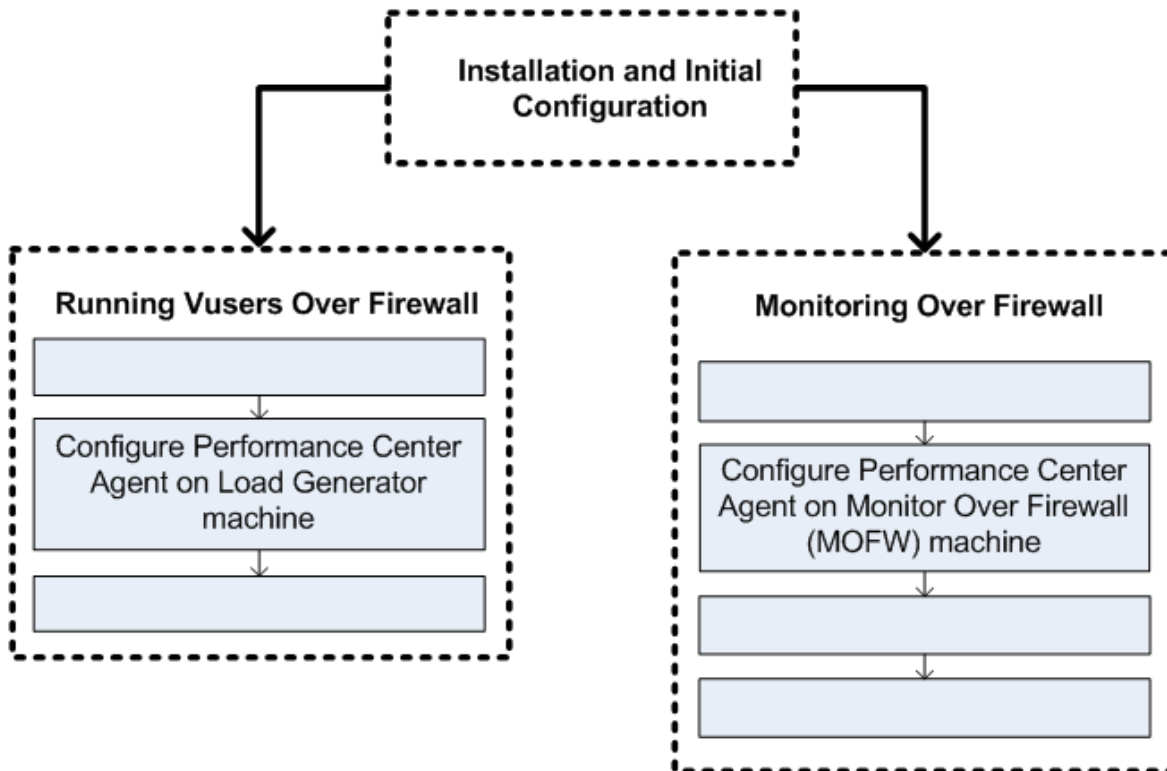

You configure the Performance Center agent to communicate with the MI Listener. The MI Listener serves as a router between the Performance Center agent and the Controller.

## Configuring the Windows Performance Center Agent

This section describes how to configure the Performance Center Agent on Windows machines to communicate with the MI Listener.

### To configure the Performance Center agent on Windows machines:

1. Select **Start > Programs > HP Performance Center Host > Advanced Settings > Performance Center Agent Configuration**, or run **<Performance Center root>\launch\_service\bin\AgentConfig.exe**.

The Agent Configuration dialog box opens.

2. Select **Enable Firewall Agent**.
3. Click **Settings**. The Agent Configuration dialog box displays a list of settings.
4. Set each option as described in ["Agent Configuration Settings " on page 105](#). Pay careful attention to the first three settings.

**Note:** When specifying the **Local Machine Key**, you must use the format `hostname_locationname` where `hostname` is the name of the host, as defined in the Hosts module in Lab Management, and `locationname` is the name of the host location, as defined in the Host Location module.

5. Click **OK** to save your changes.
6. When prompted, click **OK** to restart the Performance Center agent.
7. Check the connection status between the Performance Center agent and the MI Listener.
  - a. Change the Agent Runtime settings to run as a process and check the status. For more information, see ["Running the Performance Center Agent as a Process" on page 66](#).
  - b. If the status is OK, revert back to running it as a service. For more information, see ["Running the Performance Center Agent as a Service" on page 66](#).

**Notes:**

- When you configure the Performance Center agent on Windows machines, the Remote Management agent is automatically configured with the same settings. The Remote Management agent enables you to manage remote machines from Lab Management or from ALM.
- After you have configured the Performance Center agent on the Load Generator machine, you can edit the configuration settings from Lab Management. For more information, see the HP ALM Performance Center Guide.

## Configuring and Running the Linux Performance Center Agent

Load Generator hosts can be installed on Linux machines. This section describes how to configure and run Performance Center agents on Linux machines.

**Note:** As part of the process of configuring the Performance Center Agent on Linux machines, you also need to configure the Remote Management agent. The Remote Management agent enables you to manage remote machines from Lab Management or from ALM.

**To configure the Performance Center Agent on Linux machines:**

1. Activate the firewall service for the Performance Center agent:
  - a. Open **<Performance Center root folder>/dat/br\_inch\_server.cfg** in a text editor.
  - b. In the **Firewall** section, set **FireWallServiceActive** to **1** and save your changes.
2. Activate the firewall service for the Remote Management agent:
  - a. Open **<Performance Center root folder>/al\_agent/dat/br\_inch\_server.cfg** in a text editor.
  - b. In the **Firewall** section, set **FireWallServiceActive** to **1** and save your changes.
3. Run **agent\_config** from the **<Performance Center root folder>/bin** directory and enter the agent configuration settings (see "[Agent Configuration Settings](#)" on the next page).

**Note:** When you set the agent configuration settings, they are applied to both the Performance Center and Remote Management agents.

4. Restart the Performance Center agent for the configuration changes to take effect.
  - a. To stop the Performance Center agent, run the following command from the **<Performance Center root folder>/bin** directory:

```
m_daemon_setup -remove
```

- b. To start the Performance Center agent, run the following command from the **<Performance Center root folder>/bin** directory:

```
m_daemon_setup -install
```

**Note:** When the Performance Center agent is configured to run over a firewall, and the agent is connected to the MI Listener, a file called **<local\_machine\_key>\_connected\_to\_MI\_Listener** is created in the temporary directory of the Performance Center agent machine. This file is deleted when the Performance Center agent disconnects from the MI Listener.

5. Restart the Remote Management agent for the configuration changes to take effect.
  - a. To stop the Remote Management agent, run the following command from the **<Performance Center root folder>/al\_agent/bin** directory:

```
al_daemon_setup -remove
```

- b. To start the Remote Management agent, run the following command from the **<Performance**



Center **root folder>/al\_agent/bin** directory:

```
al_daemon_setup -install
```

## Agent Configuration Settings

The following table provides an explanation of the agent configuration settings:



| Setting                                  | Default Value | Description   |
|--|---------------|---|
| <b>MI Listener name</b>                  | none          | The host name, fully qualified domain name, or IP address of the MI Listener.   |
| <b>Local Machine Key</b>                 | none          | <p>A symbolic string identifier used to establish a unique connection between the Controller host and the agent machine, via the MI Listener machine.</p> <p>When configuring to monitor over a firewall, you can enter any logical name, using lowercase letters only.</p> <p>When configuring to run Vusers over a firewall, you must use the format <code>hostname_locationname</code> where:</p> <ul style="list-style-type: none"> <li><code>hostname</code> is the name of the host as found in Lab Management's Hosts module.</li> <li><code>locationname</code> is the name of the host location as found in Lab Management's Host Locations module.</li> </ul> |
| <b>Connection Timeout (seconds)</b>      | 20 seconds    | The length of time you want the agent to wait before retrying to connect to the MI Listener machine. If zero, the connection is kept open from the time the agent is run.   |
| <b>MI Listener User Name</b>             | none          | The user name needed to connect to the MI Listener machine.   |
| <b>MI Listener Password</b>              | none          | The password needed to connect to the MI Listener machine.  |
| <b>Server Domain</b>                     | none          | The domain name needed to connect to the MI Listener machine. This field is required only if NTLM is used.  |
| <b>Connection Type - TCP/HTTP</b>        | TCP           | Select either <b>TCP</b> or <b>HTTP</b> , depending on the configuration you are using.   |
| <b>Connection Type - HTTP Proxy Name</b> | none          | The name of the proxy server. This field is mandatory if the <b>Connection Type</b> setting is <b>HTTP</b> .  |
| <b>Connection</b>                        | none          | The proxy server connection port. This field is mandatory if the <b>Connection Type</b> setting is <b>HTTP</b> .  |

| Setting  | Default Value | Description  |
|--|---------------|--|
| <b>Type - HTTP Proxy Port</b>                                  |               |  |
| <b>Connection Type - HTTP Proxy User Name</b>                  | none          | The user name of a user with connection rights to the proxy server.  |
| <b>Connection Type - HTTP Proxy Password</b>                   | none          | The password of the user with connection rights to the proxy server.   |
| <b>Connection Type - HTTP Proxy Domain</b>                     | none          | The user's domain if defined in the proxy server configuration. This option is required only if NTLM is used.  |
| <b>Use Secure Connection (SSL)</b>                             | disabled      | Enable to connect using the Secure Sockets Layer protocol.   |
| <b>Use Secure Connection (SSL) - Check Server Certificates</b> | none          | Authenticates the SSL certificates that are sent by the server. Select <b>Medium</b> to verify that the server certificate is signed by a trusted Certification Authority. Select <b>High</b> to verify that the sender IP matches the certificate information. This setting is available only if <b>Use Secure Connection</b> is set to <b>True</b> . |
| <b>Use Secure Connection (SSL) - Private Key Password</b>      | none          | The password that might be required during the SSL certificate authentication process. This option is relevant only if the <b>Client Certificate Owner</b> option is enabled.  |

## Checking Connectivity

To run Vusers or monitor servers over a firewall, you must be able to establish a connection between the Performance Center agent, MI Listener, and the Controller machine.

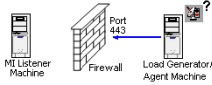
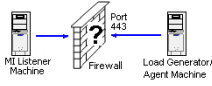
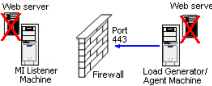
If you encounter connectivity problems after installing and configuring all the necessary components, check the table below for troubleshooting tips.

| Check   | Solution  |
|---|---|
| <p>To check that the Firewall service was activated on the agent machine:</p>    | <p><b>Windows Installation:</b></p> <ol style="list-style-type: none"> <li>1. Change the Agent Runtime settings to run as a process and check the status. For more information, see <a href="#">"Running the Performance Center Agent as a Process" on page 66.</a></li> <li>2. If the status is OK, revert back to running it as a service. For more information, see <a href="#">"Running the Performance Center Agent as a Service" on page 66.</a></li> </ol> <p>Otherwise, you need to reconfigure the Performance Center Agent on your Windows machine. For details, see <a href="#">"Configuring the Windows Performance Center Agent" on page 102.</a></p> <ul style="list-style-type: none"> <li>• <b>Linux Installation:</b></li> </ul> <p>In the temporary directory of the Performance Center Agent machine, locate the <b>&lt;local_machine_key&gt;_connected_to_MI_Listener</b> file. If the file is missing, this indicates that the <b>FirewallServiceActive=1</b> is not set in the [FireWall] section of the Agent Settings. For details, see <a href="#">"Configuring and Running the Linux Performance Center Agent" on page 103.</a></p> |
| <p>To check that port 443 is open:</p>   | <p>On the agent machine, open a command prompt window, and type the following:<br/> <code>telnet &lt;MI_Listener_IP&gt; 443.</code><br/>         For example: <code>telnet 111.111.111.1111 443.</code><br/>         If port 443 is open, a new Telnet window opens. If port 443 is not open, contact your network administrator.</p>   |
| <p>To check that port 443 is available:</p>    | <p>If a Web server is running on the MI Listener or Monitor Over Firewall machine, port 443 does not allow the access required by the listening and monitoring processes. Contact your network administrator to change the Web server port.</p>   |
| <p>To check connectivity between the agent and the MI Listener, when running the Performance Center Agent as a service:</p>  | <p>When running the Performance Center Agent as a service, do the following:</p> <ul style="list-style-type: none"> <li>• Check that port 443 is open. See <a href="#">" To check that port 443 is open: " above.</a></li> <li>• Check that the Agent Settings and Agent Configuration are correctly set. For details, see <a href="#">"About Configuring Performance Center Agents Over the Firewall" on page 102.</a></li> <li>• Run the agent as a process by launching <b>&lt;Installation&gt;\Launch_service\bin\magentproc.exe</b>. If you are successful, this indicates an authentication issue with the Performance Center Agent Service. Browse to the <b>Administrative Tools &gt; Services &gt; Performance Center Agent Service</b> and change the properties of this service to System User Account, or provide the username and password of a user who has administrative privileges on this machine.</li> </ul>   |



# Part 4: Troubleshooting



# Chapter 10: Troubleshooting

This chapter provides troubleshooting for issues that arise when installing ALM Performance Center components and during initial configuration.

This chapter includes:

- Unable to Launch any Program after Uninstalling Performance Center 11.5X .....112
- Unable to Load Windows 8 Explorer Shell After Installing Performance Center Host .....112
- During Server Setup Installation - Prerequisite Fails ..... 113
- Host Silent Installation Stops After Installing .Net Framework 4.5.1 .....113
- When Starting The Installation an Integration Error Occurs ..... 114
- Error During Installation of Prerequisite WSE 2.0 SP3 or WSE 3.0 ..... 115
- Fails to Install .NET Framework 3.5 SP1 on Windows 2008 R2, or Windows 7 SP1 or Later ..... 115
- Cannot Connect to Performance Center Server or Host .....116
- Installation Hangs When Registering Modules .....116
- Performance Center Cannot be Added to ALM Due to Mismatch in Communication Security  
Passphrase ..... 117
- Performance Center Server Cannot be Added to Lab Management: HostNotFound Error ..... 118
- Performance Center Server Cannot be Added to Lab Management: Change Machine Identity Fails .118
- Working with Performance Center when Windows Firewall is Enabled ..... 119
- Uninstall of Performance Center Failed or Has Frozen ..... 120
- Cannot Launch ALM Client: Message That Software Not Installed ..... 121
- Cannot Log in to Performance Center via the Client Machine: JavaScript Error .....121
- When Starting a Test Run, the Host is Added, but the Initializing Run Page Does Not Load .....122
- Cannot Run Performance Center Component Installation from Network Drive .....122
- Unable to Install Performance Center Components from the DVD Menu .....123
- Installing One of the Performance Center Components Cannot Use Default Port: Port Already in  
Use .....124
- Unable to Use Non-Default Ports in Microsoft SQL ..... 125
- Test Fails to Start Error Message .....126
- Unable to View Topology Monitors Online ..... 126
- Adding Server/Host to Lab Project: The Change Machine Identity Fails .....127
- Performance Center Server/Host Configuration Fails: The Process is in Use By Another Process ... 127

- [Performance Center Configuration Fails: Action Not Authorized Error](#) ..... 128
- [When Adding Performance Center Server to ALM: Fails to Ping URL](#) ..... 128

## Unable to Launch any Program after Uninstalling Performance Center 11.5X

### Problem Description

After uninstalling Performance Center 11.5X, users are unable to launch any program from their machine. This problem may occur on the Performance Center servers or hosts.

### Troubleshooting

Refer to the HP Software Self-solve knowledge base article KM01178049 (<https://softwaresupport.hp.com/group/softwaresupport/search-result/-/facetsearch/document/KM01178049>).

## Unable to Load Windows 8 Explorer Shell After Installing Performance Center Host

### Problem Description

After installing Performance Center host on Windows 8 and rebooting the machine, the windows explorer shell fails to load.

### Troubleshooting

UAC is enabled on your machine. To disable, perform the following steps:

1. Choose **Start > Run**.
2. To open the registry editor, type `Regedit` in the Run dialog box.
3. Disable UAC and restart your machine. For details on how to disable UAC, see: <http://gallery.technet.microsoft.com/Registry-Key-to-Disable-UAC-45d0df25>.



## During Server Setup Installation - Prerequisite Fails

### Problem Description

Some of the system components require installation of various software as a prerequisite to successful setup of the component.

For example, the setup of the Performance Center Server requires an installation of WSE 2.0. This installation may fail during installation of Performance Center components.

Example of the error:



### Troubleshooting

Component setup uses MSI. This error is often related to problems with the MSI engine.

Restart the machine and try again. If the problem persists, contact Microsoft.

## Host Silent Installation Stops After Installing .Net Framework 4.5.1

### Problem Description

Running the Host installation in silent mode using `setup_host.exe /s` fails to complete the installation. The installation process stops after installing .Net Framework 4.5.1.

### Troubleshooting

.Net Framework 4.5.1 replaces the .Net Framework 4.0 files. If there are any applications that are using the .Net Framework 4.0 files and are running during the installation of .Net Framework 4.5.1, you may need to restart your machine. If you are prompted to restart the machine, restart it before continuing

the installation. For more information, see: <http://msdn.microsoft.com/en-us/library/hh527997%28v=vs.110%29.aspx>.

## When Starting The Installation an Integration Error Occurs

### Problem Description

When starting the installation an error indicates that HP QC connectivity must be uninstalled before the installation can continue.

Example of error:

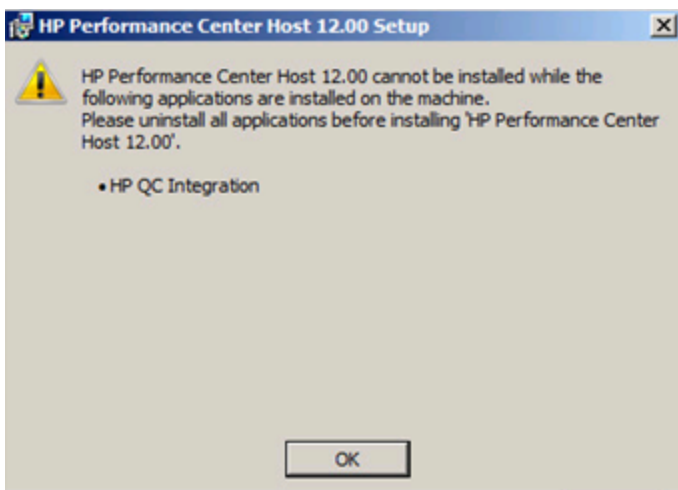

Most likely the machine you are installing on used to host HP Unified Functional Testing (UFT), which installs HP QC Connectivity for backwards compatibility with previous Quality Center versions.

### Troubleshooting

1. Open the command line and execute the following:  
`msiexec /x {EB221B44-30B0-424D-88A6-E7C42DFCC72C} /q`
2. Rerun the Performance Center installation.

## Error During Installation of Prerequisite WSE 2.0 SP3 or WSE 3.0

### Problem Description

When installing WSE 2.0 SP3 or WSE 3.0 on a machine where .NET 3.5 is not enabled, the following error occurs:

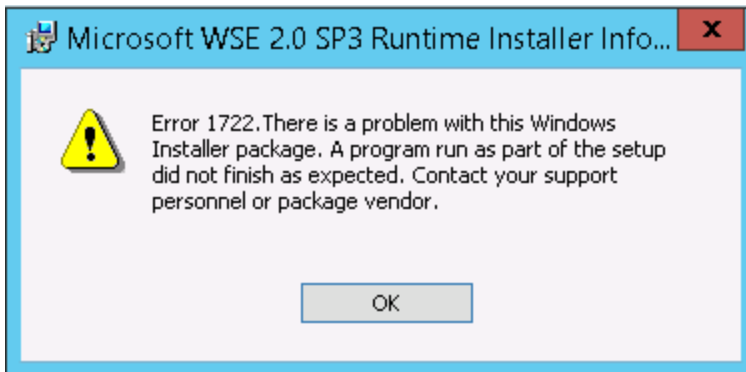

### Troubleshooting

Enable .NET 3.5 and restart the installation.

## Fails to Install .NET Framework 3.5 SP1 on Windows 2008 R2, or Windows 7 SP1 or Later

### Problem Description

While installing .NET 3.5 SP1, the installation fails and the following error is displayed:

The installation and configuration of Microsoft .NET Framework 3.5 SP1 must be made using the role management tools.

### Troubleshooting

Enable the .NET feature from the server configuration.

See also:

<http://blogs.msdn.com/b/vijaysk/archive/2009/08/16/you-must-use-the-role-management-tool-to-install-or-configure-microsoft-net-framework-3-5.aspx>

## Cannot Connect to Performance Center Server or Host

### Problem Description

Connection issues may cause different errors including:

- Inability to add Performance Center server to the system
- Inability to add Performance Center host to the system
- Ability to install the Performance Center server, but inability to view Performance Center web pages (for example: License page, Performance Test Designer, and so on)

### Troubleshooting

1. Make sure a network connection is available from one machine to the other. To check connectivity, make sure you can ping from one machine to another, or alternatively use telnet <port number>.
2. Verify that the required services are running:
  - Performance Center host: Verify that the **Performance Center Load Testing Service** is started.
  - Performance Center server:
    - i. Verify that IIS is running on the Performance Center server.
    - ii. Open the IIS manager tool and verify that the IIS Web site hosting the Performance Center virtual directories is running.
    - iii. Verify that the Performance Center application pools ('PCQCWSAppPool' and 'LoadTestAppPool') are running

## Installation Hangs When Registering Modules

### Problem Description

Both the installation and the MSI user interface hang at registering modules. This problem occurs because MSI creates a separate process for each registration action and then waits for each process to end.

### Troubleshooting

Open task manager and sort the processes by name. Locate the msixec processes that are running with the user name system. Terminate the msixec process that is consuming the highest CPU.

# Performance Center Cannot be Added to ALM Due to Mismatch in Communication Security Passphrase

## Problem Description

The Communication Security passphrase on the Performance Center server/host and the ALM server do not match. The two products cannot communicate.

## Troubleshooting

This can occur if an incorrect Communication Security passphrase was provided during the initial configuration of Performance Center, or if the passphrase on the ALM server was changed.

To resolve this issue, update the Communication Security passphrase on the ALM server and on the Performance Center server/host.

### To update the Communication Security passphrase on the ALM server:

1. Log in to Site Administration.
2. In the **Site Configuration** tab, update the **COMMUNICATION\_SECURITY\_PASSPHRASE** parameter.

### To update the Communication Security passphrase on the Performance Center server/host:

- **Option 1:** Update the communication security passphrase from the Performance Center Configuration Wizard:
  - a. From the Performance Center server:  
Choose **Start > All Programs > HP Software > Performance Center Server > Tools > Server Configuration Wizard**.
  - From the Performance Center host:**  
Choose **Start > All Programs > HP Software > Performance Center Host > Tools > Server Configuration Wizard**.
  - b. On the Communication Security page, enter the new Communication Security passphrase.
  - c. Click **Next** on all of the subsequent wizard pages and **Finish** to close the wizard.
- **Option 2:** Update the communication security passphrase directly on each Performance Center machine:
  - **Performance Center server:** On the Performance Center Server, navigate to the **PCS.config** file as follows: <Performance Center Server path>\dat\PCS.config. Under the **<appSettings>** tag, the value appears by the **LW\_CRYPT0\_INIT\_STRING** key.
  - **Performance Center host:** On the host, navigate to the **LTS.config** file as follows:

<Performance Center Host path>\dat \LTS.config. Under the **<appSettings>** tag, the value appears by the **LW\_CRYPTO\_INIT\_STRING** key.

## Performance Center Server Cannot be Added to Lab Management: HostNotFound Error

### Problem Description

When adding a Performance Center server, the ALM system performs a name lookup operation. At times, the system changes the IP address or the short DNS name into a full DNS name. When this situation occurs, the system fails to add the server because the name is incorrect.

### Troubleshooting

Validate that the Performance Center server URL is correct. Make sure that the server is up and that it can be reached from the ALM server.

If the problem persists, add the fully qualified name of the Performance Center server to the Host file (typically under c:\Windows\System32\drivers\etc) on ALM and the Performance Center server.

## Performance Center Server Cannot be Added to Lab Management: Change Machine Identity Fails

### Problem Description

When adding a Performance Center server to Lab Management, the "Change Machine Identity failed" error occurs.

When this error occurs, the IIS configuration is trying to access registry keys that no longer exist. (The log file displays the following error: "Illegal operation attempted on a registry key that has been marked for deletion.").

### Troubleshooting

Reset the IIS. If the problem persists, restart the Performance Center server machine.

# Working with Performance Center when Windows Firewall is Enabled

## Problem Description

To work with Performance Center, we recommend that you disable the Windows Firewall on all host machines. To enable Performance Center to work with the Windows Firewall enabled, the Windows Firewall must be reconfigured.

## Troubleshooting

The Windows Firewall must be configured to allow inbound and outbound communication on specific ports used by Performance Center.

The following configurations are required for all Performance Center machines in the system (servers and hosts), except for Site Scope and Diagnostics.

### Performance Center server:

| Process / Service                             | Direction | Protocol | Local Port | Remote Port   | Path  |
|---|-----------|----------|------------|---|---|
| Datacollectionagent.exe                       | Inbound   | TCP      | 3333       | Any   | <PCS install dir>\bin\datacollectionagent.exe                       |
| World Wide Web Services (HTTP Traffic-In)     | Inbound   | TCP      | 80         | Any   | Service   |
| RemoteManagement Agent Service                | Inbound   | TCP      | 54245      | Any   | <PCS install dir>\al_agent\bin\alagentservice.exe                   |
| HP.PC.LTOP.QCOTA OperationService Wrapper.exe | Outbound  | TCP      | Any        | 8080  | < PCS install dir>\bin\HP.PC.LTOP.QCOTA OperationServiceWrapper.exe |
| ALWrapperServer.exe                           | Outbound  | TCP      | Any        | 54245   | <PCS install dir>\bin\ALWrapperServer.exe                           |
| w3wp.exe                                      | Outbound  | TCP      | Any        | 8080, 8731, 1433, 3333<br>(Use port 1433 for MS SQL Server. For Oracle, use port 1521.) |   |

### Hosts:

| Process/ Service               | Direction | Protocol | Local Port | Remote Port | Path   |
|--------------------------------|-----------|----------|------------|-------------|--|
| Datacollectionagent.exe        | Inbound   | TCP      | 3333       | Any         | <Host install dir>\bin\datacollectionagent.exe     |
| RemoteManagement Agent Service | Inbound   | TCP      | 54245      | Any         | <Host install dir>\al_agent\bin\alagentservice.exe |
| Performance Center Agent       | Inbound   | TCP      | 54345,     | Any         | <Host install dir>\launch_service                  |

|   |          |     |       |          |  |
|---|----------|-----|-------|----------|--|
| Service   |          |     | 50500 |          | \\bin\magentservice.exe  |
| System  | Inbound  | TCP | 8731  | Any      |  |
| HP.PC.LTOP.QCOTA<br>OperationService<br>Wrapper.exe | Outbound | TCP | Any   | 8080     | <Host install dir>\bin<br>\HP.PC.LTOP.QCOTAOperation<br>ServiceWrapper.exe |
| LTOPSvc.exe   | Outbound | TCP | Any   | 80, 8080 | <Host install dir>\bin<br>\LTOPSvc.exe                                     |

## Uninstall of Performance Center Failed or Has Frozen

### Problem Description

This error may present itself in various ways:

- Uninstall of Performance Center did not complete successfully.
- Uninstall of Performance Center is taking a long time and seems to have frozen.
- When trying to uninstall Performance Center again, Performance Center is not found in Add/Remove Programs.

### Troubleshooting

- Reboot the machine and uninstall again (unless Performance Center no longer appears in Add/Remove Programs).
- Alternatively, you can:
  - a. Open a command prompt and run:  
**<Host installation path>\bin\HP.PC.PCS.Configurator.exe /CFG:...\dat\setup\lts\xml\Configurator.xml /G:Uninstall**
  - b. Delete the host installation folder. The default path for the host installation folder on a Windows 2008 64-bit machine is:  
**C:\Program Files (x86)\HP\Performance Center Host**
  - c. Delete **HP Performance Center Host** from **Start menu > Programs**.
  - d. Delete the product from the MSI manager using the Windows Installer CleanUp Utility (<http://www.windows-installer-cleanup-utility.com/>).



## Cannot Launch ALM Client: Message That Software Not Installed

### Problem Description

When launching the ALM client, a message such as the following is displayed:

**"Microsoft Visual C++ 2005 SP1 ATL Security Update Redistributable is not installed.** Application will not be able to run. Contact your system administrator."

### Troubleshooting

This problem occurs if one of the client prerequisites, .NET Framework 4.0 or Microsoft Visual C++ 2005 SP1 ATL Security Update Redistributable, is not installed.

To solve this problem, install the software manually from the following locations:

|   |  |
|---|--|
| .NET Framework 4.0  | <Installation_Disk_Root_Directory>\Setup\Common\dotnet4.0  |
| Microsoft Visual C++ 2005 SP1 Redistributable Package (x86) | <Installation_Disk_Root_Directory>\Setup<environment>\prerequisites\vc2005_sp1_redist\vc redistrib_x86.exe |

## Cannot Log in to Performance Center via the Client Machine: JavaScript Error

### Problem Description

Login to Performance Center fails, and the following error is displayed:

**JavaScript is not installed or is disabled in your browser.**

### Troubleshooting

This problem is related to running JavaScript in your browser.

To resolve this issue:

1. In Internet Explorer, select **Tools > Internet options > Security**.
2. Select **Internet zone**.
3. Click **Custom Level**.

4. Make sure that **Active Scripting** is enabled.
5. Enable the following items under **ActiveX controls and Plug-ins**:
  - **Automatic prompting for ActiveX controls**
  - **Binary and script behaviors**
  - **Run ActiveX controls and plugins**
  - **Script ActiveX controls marked safe for scripting**

## When Starting a Test Run, the Host is Added, but the Initializing Run Page Does Not Load

### Problem Description

When starting a test run, the host is added, but the Initializing Run page does not load.

### Troubleshooting

The client machine needs to have access to the machine. For example, if the Administrator inserted the machine name without the domain, you might need to add the IP address and machine name to the host file (C:\WINDOWS\system32\drivers\etc\hosts) on the client machine.

## Cannot Run Performance Center Component Installation from Network Drive

### Problem Description

Cannot run the setup (Performance Center Server or host) when attempting to run it from a network drive.

### Troubleshooting

To run **setup.exe** from a network location, you need to add the network server location to your Trusted Sites, and then run setup.exe again.

#### **To add the network server to your Trusted Sites in Internet Explorer:**

1. Open **Tools > Internet Options**.
2. Select the **Security** tab and click **Trusted Sites**:

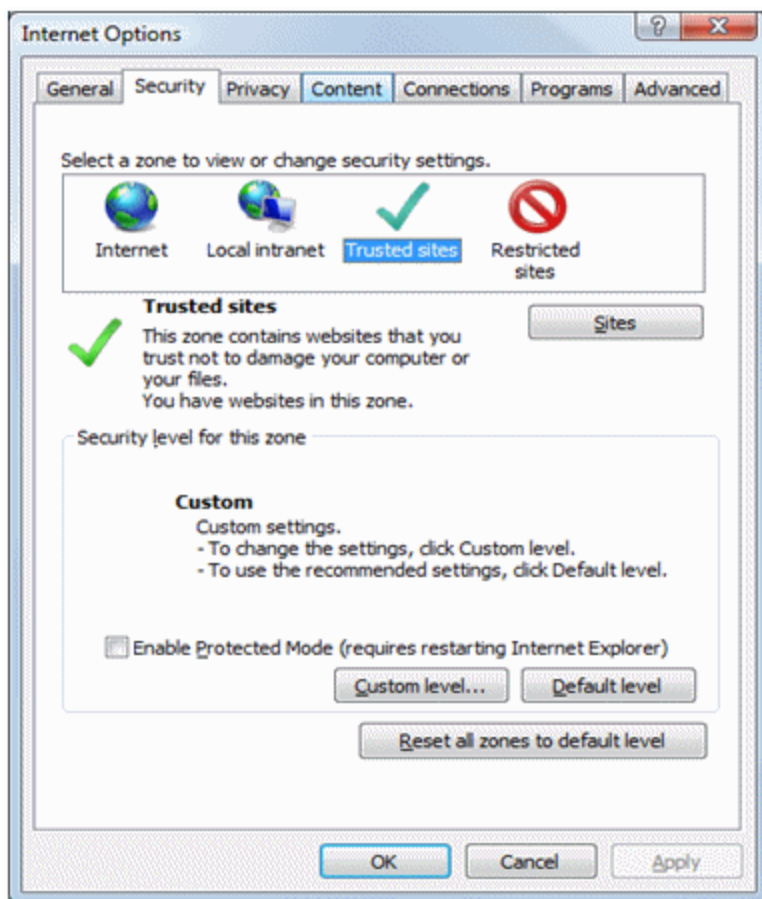

3. Click **Sites**.
4. In the Trusted Sites dialog box, add the location of the network server where the Performance Center component setup file is located, to the list of trusted sites.

## Unable to Install Performance Center Components from the DVD Menu

### Problem Description

When clicking the installation option on the DVD menu nothing happens.

### Troubleshooting

1. Make sure the user running the installation has sufficient permissions to launch executable files.
2. Restart the machine and try again.

# Installing One of the Performance Center Components Cannot Use Default Port: Port Already in Use

## Problem Description

The installation cannot use a default port because it is already in use.

## Troubleshooting

If the installation cannot use a default port because it is already in use, change the port as per the instructions in the following table:

| Component                                   | How to change the port  |
|---|---|
| <b>Performance Center Server IIS</b>        | To change this port, see <a href="http://support.microsoft.com/kb/149605">http://support.microsoft.com/kb/149605</a> .  |
| <b>Performance Center host</b>              | <p>To change port 8731 to a different port:</p> <ol style="list-style-type: none"> <li>On each Performance Center host, open <b>LTOPSvc.exe.config</b> (located in <b>&lt;Host Installation directory&gt;\bin\</b>) and change all four occurrences of <b>8731</b> to a new port number. Restart the <b>Performance Center Load Testing Service</b>.</li> <li>On the Performance Center Server, open <b>pcs.config</b> (located in <b>&lt;Performance Center Server Installation directory&gt;\dat\</b>). Under <b>PCSSettings</b>, change <b>ltopPortNumber</b> to the new port number.</li> </ol>   |
| <b>MI Listener</b>                          | <p>To change port 443 to a different port, perform the following steps on the following machines:</p> <ul style="list-style-type: none"> <li>Controller machine (if used as MI Listener)</li> <li>Load Generator machine</li> <li>MI Listener</li> </ul> <p>To change port 443:</p> <ol style="list-style-type: none"> <li>Open <b>&lt;Component installation directory&gt;\launch_service\dat\drv.dat</b> and locate the <b>[launcher]</b> section.</li> <li>Add <b>OFWPort=&lt;port&gt;</b>, where &lt;port&gt; is the new port number.</li> <li>Go to <b>&lt;Component installation directory&gt;\launch_service\dat\channel_configure.dat</b> and locate the <b>[General]</b> section.</li> <li>Add <b>OFWPort=&lt;port&gt;</b>, where &lt;port&gt; is the new port number.</li> <li>Restart the agent.</li> </ol> <p><b>Note:</b> There is no support for changing port 50500.</p> |
| <b>LoadRunner/ Performance Center Agent</b> | <p>Changing the port for a Controller machine:</p> <ol style="list-style-type: none"> <li>Stop 'Performance Center Agent Service'.</li> </ol>   |

| Component                                    | How to change the port  |
|--|---|
|  | <ol style="list-style-type: none"> <li>2. Open for edit the file: &lt;Install folder&gt;\dat\merc_agent.cfg</li> <li>3. Under the [Attributes] section, add the line: "AgentPort=&lt;New Port Value&gt;"</li> <li>4. Restart the service.</li> </ol> <p>Changing the port for a Load Generator machine:</p> <ol style="list-style-type: none"> <li>1. Stop 'Performance Center Agent Service' (can also be called 'Load Runner Agent Service').</li> <li>2. Open for edit the file: &lt;Install folder&gt;\launch_service\dat\merc_agent.cfg</li> <li>3. Under the [Attributes] section, add the line: "AgentPort=&lt;New Port Value&gt;"</li> <li>4. Restart the service.</li> </ol> |
| <b>Autolab Agent (RemoteManagementAgent)</b> | <p>This service is used to perform administration tasks on all Performance Center machines. By default, Autolab Agent is using port 54245. The port number can be changed. However, the new value must be configured on each machine (server, host, Load Generator).</p> <p>To change the port:</p> <ol style="list-style-type: none"> <li>1. Stop 'RemoteManagementAgent'.</li> <li>2. Open &lt;Install folder&gt;\launch_service\al_agent\dat\merc_agent.cfg</li> <li>3. Under the [Attributes] section, add the line: "AgentPort=&lt;New Port Value&gt;"</li> <li>4. Restart the service.</li> </ol>   |
| <b>SiteScope (Topology)</b>                  | <p>In Performance Center, change the port of the Topology entity to the same port as that defined during the SiteScope configuration.</p>   |
| <b>SiteScope (Topology) - SSL</b>            | <p>In Performance Center, change the port of the Topology entity to the same port as that defined during the SiteScope configuration.</p>   |
| <b>SiteScope (Monitor Profiles)</b>          | <p>In Performance Center, change the port of the Monitor Profile entity to the same port as that defined during the SiteScope configuration.</p>  |
| <b>Diagnostics Server</b>                    | <p>In Lab Management, change the port of the Diagnostics Server entity to the same port as that defined during the Diagnostics Server configuration.</p>  |
| <b>Diagnostics Server - SSL</b>              | <p>In Lab Management, change the port of the Diagnostics Server entity to the same port as that defined during the Diagnostics Server configuration.</p>  |

## Unable to Use Non-Default Ports in Microsoft SQL

### Problem Description

Performance Center does not work on non-default ports in Microsoft SQL.

## Troubleshooting

The Microsoft SQL instance must use a static port. The correct port must be defined in the connection string.

## Test Fails to Start Error Message

### Problem Description

An error message is not issued when a performance test fails to start.

### Troubleshooting

This problem is possibly caused by the configuration process. Validate the following:

- The **Performance Center LoadTesting Service** is running on the host machine under the system account.
- The PC user (**IUSR\_METRO**) exists.
- In the **wlrun7.ini**, under the **%systemroot%** folder, make sure that **IsOrchid** and **IsOrchid10** are both set to 1. For more information, see HP Software Self-solve knowledge base article KM1098097 (<https://softwaresupport.hp.com/group/softwaresupport/search-result/-/facetsearch/document/KM1098097>).

## Unable to View Topology Monitors Online

### Problem Description

When running a load test that contains topology, the topology monitors data is not shown. You may get the following error when clicking the topology tab view: This node does not have a monitor.

### Troubleshooting

1. On the Host machine, validate that **EnableInUi** is set to **1** in **<install folder> dat\online\_graphs\online\_resource\_graphs.rmd**
2. In Sitescope, set the monitor frequency value (by default it is set to 10 minutes). Make sure it is set for less than 10 seconds.

## Adding Server/Host to Lab Project: The Change Machine Identity Fails

### Problem Description

When adding a Performance Center server or host to Lab Management, the following is displayed: **"Change machine identity failed"** or **"Change machine identity failed. Reason: No such interface supported"**.

### Troubleshooting

1. The Windows operating system is unstable. It is preventing Performance Center from updating user details.
2. Reboot your machine.

## Performance Center Server/Host Configuration Fails: The Process is in Use By Another Process

### Problem Description

After running the Performance Center Server Configuration wizard, the following error is displayed in the log file:

**"The process cannot access the file 'C:\Windows\Microsoft.NET\Framework\v4.0.30319\config\machine.config' because it is being used by another process."**

This problem occurs when the configuration updates the .NET machine.config file while it is in use by another process (for example, IIS). When the file is in use, the update fails.

### Troubleshooting

Restart the machine and start the Performance Center Server Configuration wizard.

## Performance Center Configuration Fails: Action Not Authorized Error

### Problem Description

Performance Center configuration fails with an Action not authorized message.

### Troubleshooting

Ensure that the ALM internal URL and the Performance Center server internal URL are correct.

## When Adding Performance Center Server to ALM: Fails to Ping URL

### Problem Description

When adding a Performance Center server to Lab Management, a "Failed to ping URL" error occurs. This problem occurs when the Performance Center server is unreachable.

### Troubleshooting

1. Verify that the Performance Center server is running and that you can ping to it from the ALM server.
2. Verify that IIS is running on the Performance Center server.
3. Open the IIS manager tool and verify that the IIS Web site hosting the Performance Center virtual directories is running.
4. Verify that the Performance Center application pools ('PCQCWSAppPool' and 'LoadTestAppPool') are running.
5. From the Performance Center server, open Internet Explorer and verify that following URL can be accessed: <http://localhost/pcs/LabService.svc?wsdl>  
A page with details about the web service should open.
6. If you manage to complete steps 1 to 5 successfully:
  - a. From ALM, open Internet Explorer and enter the above URL. Replace the value **localhost** twice, once with the fully qualified name of the Performance Center server, and once with the IP address.



- b. If the above step works, try to re-add the Performance Center server to ALM. Use the fully qualified name or IP address.

If the above step fails, there is probably a problem with the network and/or communication between ALM and Performance Center. Contact your network administrator for assistance.

7. If you are unable to complete steps 1 - 5 successfully:
  - a. Open the Performance Center server.
  - b. Stop the IIS on the Performance Center server.
  - c. Open the cmd box, and enter `netstat -ano | findstr :443`
  - d. You will see the service ID number that uses port 443.
  - e. Select **Windows Task Manager > Services tab**.
  - f. Stop the service using the service ID number.
  - g. Repeat steps **c** to **f**, for port used by the IIS's web site hosting the Performance Center server virtual directories (typically port 80).
  - h. Start IIS and verify that the web site hosting the Performance Center server (typically 'Default Web Site') is running.
  - i. In Lab Management, add the Performance Center server.



## Send Us Feedback



Can we make this Installation Guide better?

Tell us how: [SW-Doc@hp.com](mailto:SW-Doc@hp.com)

